

Owner's Manual

ID.4

Edition 01/2023

United States version

Teil-Nr.: 11K012723SB

Print status: 19.08.2022

English USA: 2023.01

V1, R1, USA, en_US

Vehicle-specific information can be entered below:

Vehicle Identification Number (VIN)																

Vehicle information	
Engine output (kW)	
Engine code	
Transmission code	
Paint number	

PR number	Vehicle service type

Notes

Delivery inspection was performed on:	Date of delivery/first approval (whichever occurs first):
Volkswagen dealer stamp	Volkswagen dealer stamp



WARNING

Operating, servicing and maintaining a passenger vehicle or off-highway motor vehicle can expose you to chemicals including phthalates and lead, which are known to the State of California to cause cancer and birth defects or other reproductive harm. To minimize exposure, wear gloves or wash your hands frequently when servicing your vehicle. For more information go to www.P65Warnings.ca.gov/passenger-vehicle.

W20-0395

Fig. 1

Volkswagen AG works constantly to improve all of its products. Due to ongoing vehicle development, changes in design, equipment, and technology are possible at any time. The information regarding equipment, appearance, performance, dimensions, weights, fuel consumption, standards, and functions of the vehicle is the information that was available at the time of the editorial deadline for this manual. Some of the equipment and functions may not be available until later or may be available only in certain countries. Contact your local authorized Volkswagen dealer or authorized Volkswagen Service Facility for more information.

The vehicle shown may be equipped with optional equipment for an additional price and is only offered in certain markets. An authorized Volkswagen dealer can inform you about differences in your particular country. Subject to change. No legal obligations or commitments may be derived from the information, illustrations, and descriptions in this manual.

No reprint, reproduction, or translation of this Manual is permitted, even in excerpts, without the express written consent of Volkswagen AG.

Volkswagen AG expressly reserves all rights under applicable copyright law. Subject to change.

© 2023 Volkswagen AG

We thank you for buying a Volkswagen vehicle

This Volkswagen vehicle is equipped with advanced technology incorporating a number of convenience features for you to enjoy in your daily driving.

Please carefully read and follow the information in this Owner's Manual. It will help you to become more familiar with your vehicle and to be able to recognize and avoid hazardous situations for you and others.

If you have questions about your vehicle or if you believe that the manual is not complete, please contact your authorized Volkswagen dealer or your authorized Volkswagen Service Facility. Authorized Volkswagen dealers and authorized Volkswagen Service Facilities always welcome your questions, suggestions, and constructive criticism.

We hope you enjoy driving your vehicle and we wish you safe and pleasant motoring.

WARNING

Follow the important safety instructions about using child restraint systems in the front passenger seat →  [Introduction](#)

About this Owner's Manual

This Owner's Manual is valid for all models and versions of your Volkswagen model and model year. The Owner's Manual describes all equipment and models without indicating special equipment or model versions. This may include descriptions of equipment that your vehicle may not have or that may only be available in some countries.

You can find details of your actual vehicle equipment in your sales documentation or by contacting an authorized Volkswagen dealer or authorized Volkswagen Service Facility. Volkswagen recommends contacting an authorized Volkswagen dealer or authorized Volkswagen Service Facility.

This Owner's Manual describes a passenger vehicle.

All information in this Owner's Manual was correct at the time of printing. Due to continuous vehicle development, there may be differences between your vehicle and the information in this Owner's Manual. No legal commitment can be derived from the information, illustrations, or descriptions in this manual.

Due to legal and technical requirements, the vehicle may be provided with different Owner's Manual variants depending on the country.

Printed Owner's Manual

The printed Owner's Manual describes the range of functions of the vehicle at the time of release. Additions and amendments to the Owner's Manual may also be added in the form of supplements.

An alphabetically ordered keyword index as well as a list of abbreviations that explains technical abbreviations and designations are included to assist with orientation and understanding of the printed manual.

 **Make sure that the printed documents are in the vehicle if you wish to sell or lend the car. Volkswagen also recommends resetting the Infotainment system to its factory settings in order to delete all personal data.**

Explanations

Brief definitions are placed in front of some sections in a different color to summarize the topic in question. Detailed information about the systems and equipment along with their properties, conditions, and system limitations is included in the associated sections.

The following section explains phrasings and terms found in the Owner's Manual to help understanding.

Directions

Directions (left, right, front, back) are in reference to the driving direction unless noted otherwise.

Units and speeds

The display in miles instead of kilometers or mph instead of km/h is determined by the versions of the instrument cluster and Infotainment system that are installed, which varies depending on the country where the vehicle is sold.

Illustrations

Illustrations are only for orientation and are simply used to provide a visual display of descriptions and instructions. The illustrations may differ from your vehicle.

This Owner's Manual was created for left-hand drive vehicles. For *vehicles with right-hand drive steering*, controls are sometimes arranged differently from what is shown in the illustrations or described in the text.

Form of address

To improve readability, plural pronouns are used here to refer to a singular subject of any gender. This applies to all genders equally. The use of abbreviations are for editorial purposes and do not contain any evaluation.

Terms used and their meanings:

Sunroof The term "power sunroof" is used as a synonym for all variants of the tilting and sliding panoramic sunroof depending on the vehicle equipment.









Authorized Volkswagen dealer or authorized Volkswagen Service Facility Authorized Volkswagen dealer or authorized Volkswagen Service Facility refers to workshops with instructed or trained personnel that specialize in servicing passenger vehicles. A qualified professional can be an authorized Volkswagen dealer or authorized Volkswagen Service Facility or an independent workshop.

Authorized Volkswagen dealer or authorized Volkswagen Service Facility Authorized Volkswagen dealer or authorized Volkswagen Service Facility refers to workshops that have a contractual relationship with Volkswagen. This contractual relationship means that they have access to more information as well as a direct line of communication to the manufacturer.

Contact an authorized Volkswagen dealer or authorized Volkswagen Service Facility In some situations, it is necessary for you to drive your vehicle to an authorized Volkswagen dealer or authorized Volkswagen Service Facility so that it can be checked.

Contact an authorized Volkswagen dealer or authorized Volkswagen Service Facility for assistance If it is no longer possible to continue driving your vehicle, it is necessary to have it checked directly where it is by a professional. A decision regarding whether the vehicle can continue to be driven following inspection or whether it needs to be towed must then be made depending on the circumstances.

Explanation of symbols

	Indicates a reference to a section within a chapter containing important information and safety warnings  that should always be heeded.
	The arrow indicates the end of a section.
	This symbol indicates situations where the vehicle must be stopped as quickly as possible.
TM	The symbol means "Trademark" and indicates a recognized but not (yet) officially registered trademark. However, the absence of this symbol does not constitute a waiver of any rights associated with intellectual property.
	This symbol indicates a registered trademark. However, the absence of this symbol does not constitute a waiver of any rights associated with intellectual property.
	Symbols of this type refer to warnings in the same section or on the specified page, pointing out possible risks that can cause accidents and personal injuries and how to help prevent them.
	
	
	Cross-reference to a warning of potential property damage, in the same section or on the specified page.

DANGER

DANGER indicates a hazardous situation which, if not avoided, will result in death or serious injury.

WARNING

WARNING indicates a hazardous situation which, if not avoided, could result in death or serious injury.

CAUTION

CAUTION indicates a hazardous situation which, if not avoided, could result in minor or moderate injury.

NOTICE

NOTICE is used to address practices not related to physical injury, but related to damage to the vehicle.

 Texts with this symbol contain information about the environment and how you can help to protect it.

 Texts with this symbol contain supplementary information.

Vehicle overviews

View from the front

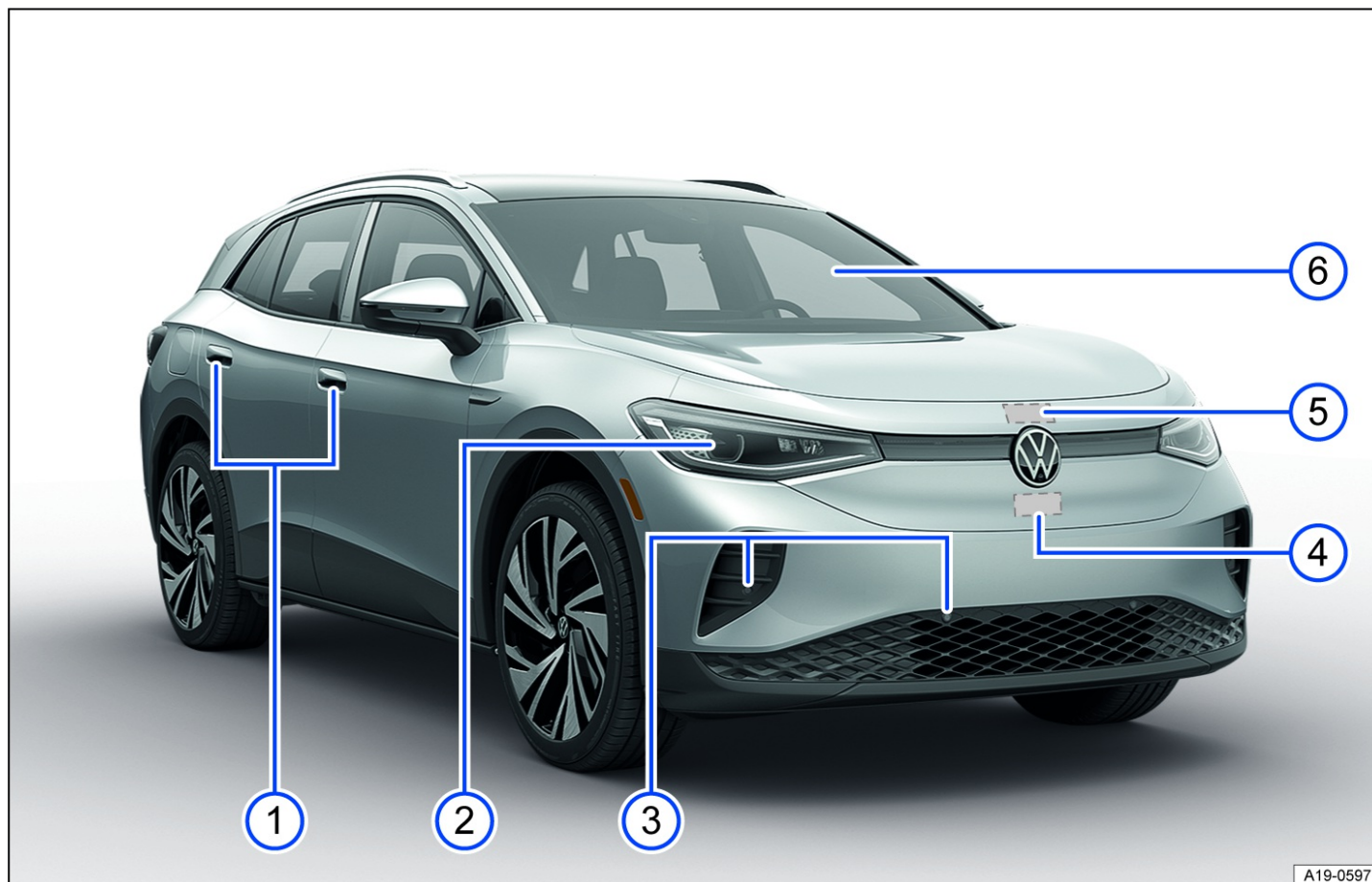

A19-0597

Fig. 2 Overview of vehicle from the front.

- ① Door handles ⇒ *Doors and central locking button*
- ② Headlights ⇒ *Exterior lighting*
- ③ Sensors for assistance systems ⇒ *Exterior care and cleaning*
- ④ Behind a cover: Radar sensor for assistance systems ⇒ *Exterior care and cleaning*
- ⑤ Opening lever for the hood with the hood space underneath ⇒ *Opening and closing the hood*
- ⑥ Windshield:
 - With VIN ⇒ *Technical data*
 - With windshield wipers ⇒ *Operating the windshield wiper lever*
 - with windshield defroster ⇒ *Windshield defroster*
 - With camera for assistance systems in the interior rearview mirror area ⇒ *Exterior care and cleaning*
 - With rain/light sensor in the interior rearview mirror area ⇒ *Rain/light sensor, ⇒ Exterior care and cleaning*

Rear view

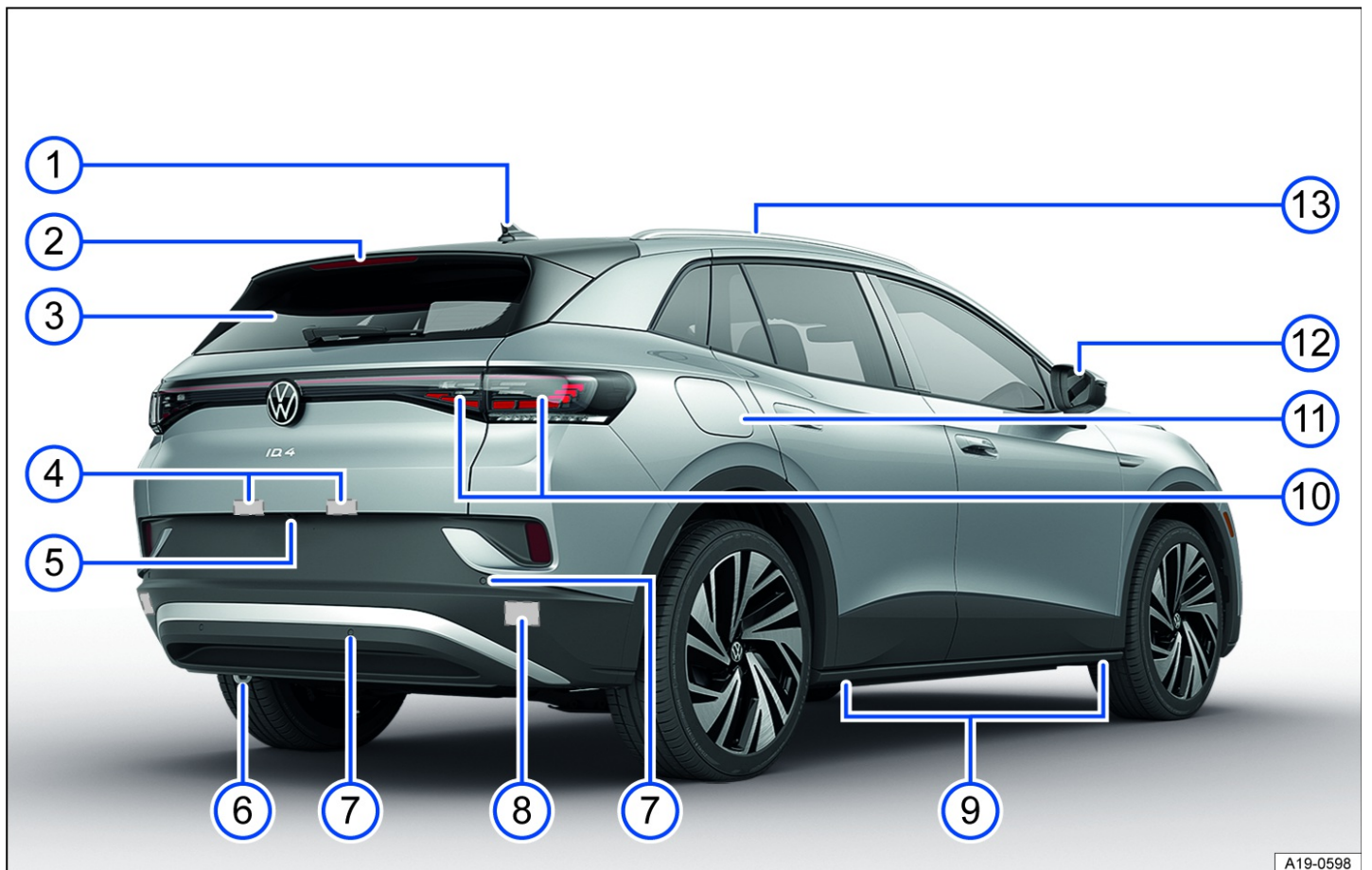

A19-0598

Fig. 3 Rear vehicle overview.

- ① Roof antenna
- ② High-mounted brake light
- ③ Rear window:
 - With rear window defroster ⇒ *Rear window defroster*
 - With rear window wiper ⇒ *Operating the windshield wiper lever*
 - With window antenna
- ④ Number plate light ⇒ *Exterior lighting*
- ⑤ Area:
 - Button to open the trunk lid ⇒ *Trunk lid*
 - Camera for parking systems ⇒ *Rear View Camera, ⇒ Exterior care and cleaning*
- ⑥ Towing eye ⇒ *Towing*
- ⑦ Sensors for assistance systems ⇒ *Exterior care and cleaning*
- ⑧ Behind the bumper: radar sensor for assistance systems ⇒ *Exterior care and cleaning*
- ⑨ Mounting points for the vehicle jack ⇒ *Wheel change*
- ⑩ Taillights and reflectors ⇒ *Exterior lighting*
- ⑪ Charging socket flap ⇒ *Charging*
- ⑫ Outside mirrors ⇒ *Outside mirrors*
 - with Lane Change System (Side Assist) display ⇒ *Introduction*
- ⑬ Roof rails ⇒ *Roof rack*

Driver door

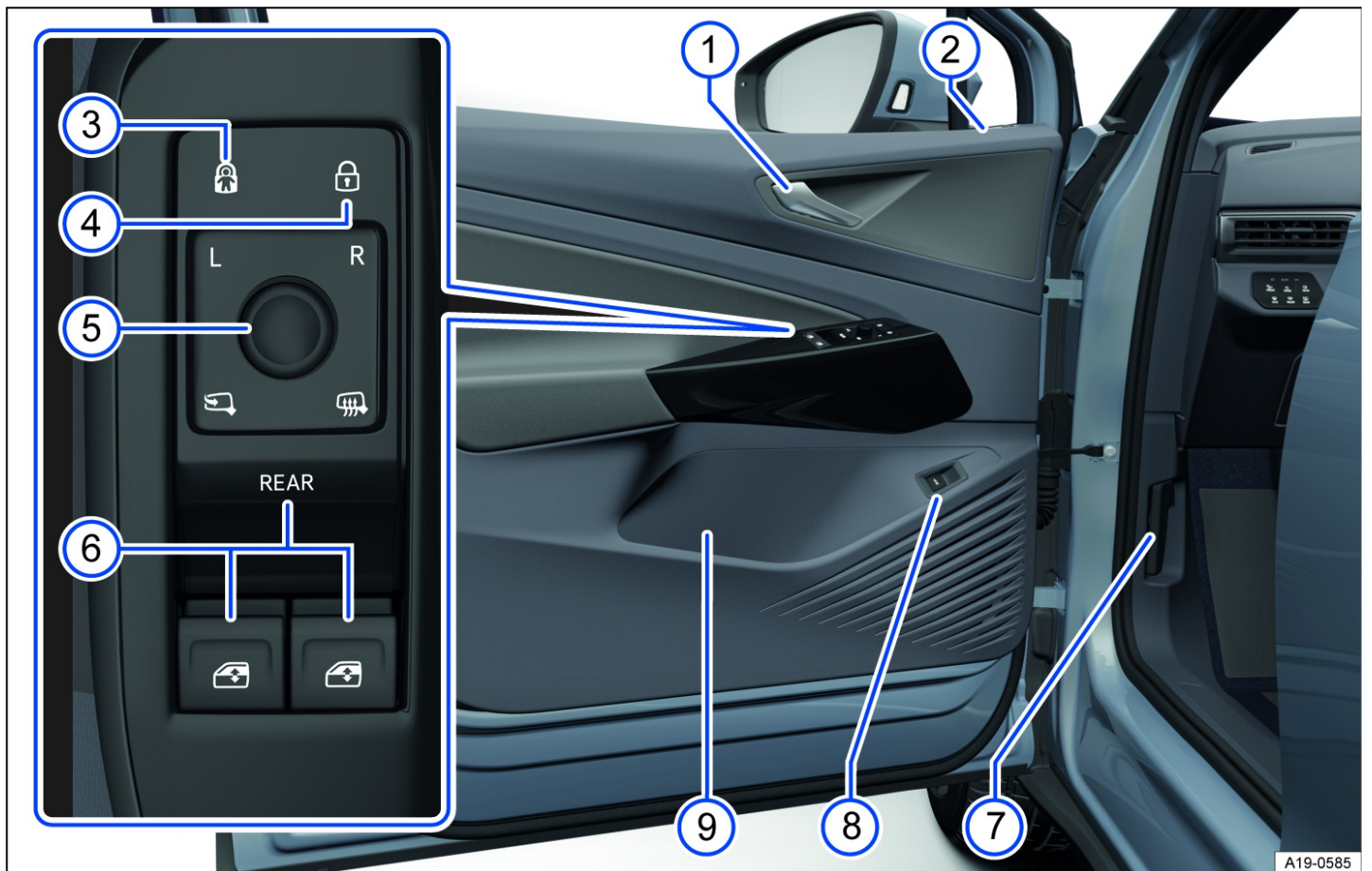

Fig. 4 Driver door (left-hand drive vehicle): controls (right-hand drive vehicles are a mirror image).

- ① Door handle
- ② Central locking indicator light ⇒ *Indicator light in the driver's door*
- ③ Control
 - For deactivating the rear power window switches ⇒ *Opening and closing the windows*
 - For activating the electric child safety lock ⇒ *Electrical childproof lock*
- ④ Control panel for locking and unlocking the vehicle ⇒ *Control for central locking*
- ⑤ Knob for outside mirror positions and functions ⇒ *Outside mirrors*
- ⑥ Buttons for operating the power windows ⇒ *Opening and closing the windows*
- ⑦ Hood release lever ⇒ *Opening and closing the hood*
- ⑧ Button to open the trunk lid ⇒ *Trunk lid*
- ⑨ Storage compartment
 - With cup holder
 - With storage option for a reflective vest ⇒ *Emergency equipment*

Driver side

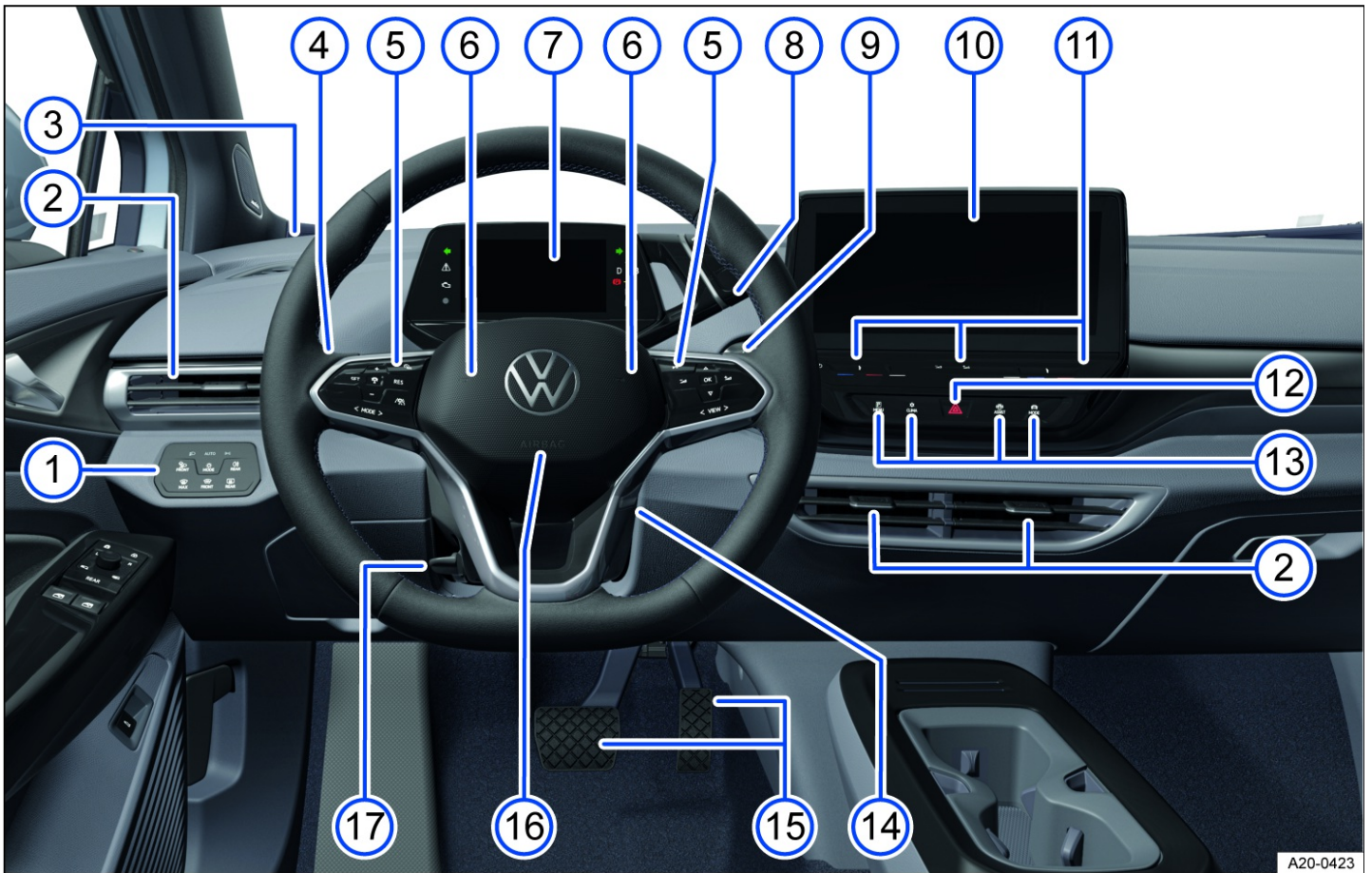

Fig. 5 Driver's side overview.

① Controls

- For light functions ⇒ *Headlights*
- For window heating and ventilation ⇒ *Rear window defroster, ⇒ Air distribution and blower speed*

② Vents ⇒ *Air distribution and blower speed*

③ ID. Light (luminous band between windshield and instrument panel) ⇒ *ID. Light*

④ Turn signal and high beam lever ⇒ *Switching the turn signals on and off, ⇒ Switching the high beam headlights on and off*

⑤ Multi-function steering wheel controls

- For driver assistance systems ⇒ *Driver assistance systems*
- For audio, navigation ⇒ *Infotainment system*
- For adjusting the volume ⇐ ⇨
- For voice operation activation 🗣️ (may not function depending on the equipment) ⇒ *Voice control*
- For switching between the ID. cockpit views <VIEW> ⇒ *Operating the Volkswagen Digital Cockpit*

⑥ Horn

⑦ ID. Cockpit ⇒ *ID. Cockpit*

- With warning and indicator lights and gear selector display ⇒ *Symbols in the instrument cluster*

⑧ Selector lever ⇒ *Gear selection*



- With electronic parking brake button (P) ⇒ *Electronic parking brake*

⑨ Windshield wiper/washer lever ⇒ *Window wipers*

⑩ Infotainment system ⇒ *Infotainment system*





⑪ Controls

- For switching the Infotainment system on and off 🔌 ⇒ *Overview and controls of the 12" version, ⇒ Overview and controls of the 10" version*
- For the temperature setting of the air conditioner or the heating and fresh air system ⇒ *Heating and air conditioning system*

- For adjusting the volume  

12 Control for switching the emergency flashers on or off  ⇒ *In case of an emergency*

13 Controls

- For the air conditioning system, heating and fresh air system  ⇒ *Heating and air conditioning system*
- for Driving Mode Selection  ⇒ *Driving Mode Selection*
- For driver assistance systems  ⇒ *Driver assistance systems*
- For parking and maneuvering assist systems  ⇒ *Parking and maneuvering*

14 Starter button ⇒ *Switching the ignition on and off*

15 Pedals ⇒ *Information on the pedals*

16 Installation location of driver's front airbag ⇒ *Airbag system*

17 Lever for adjusting the steering wheel position ⇒ *Steering wheel*

Center console

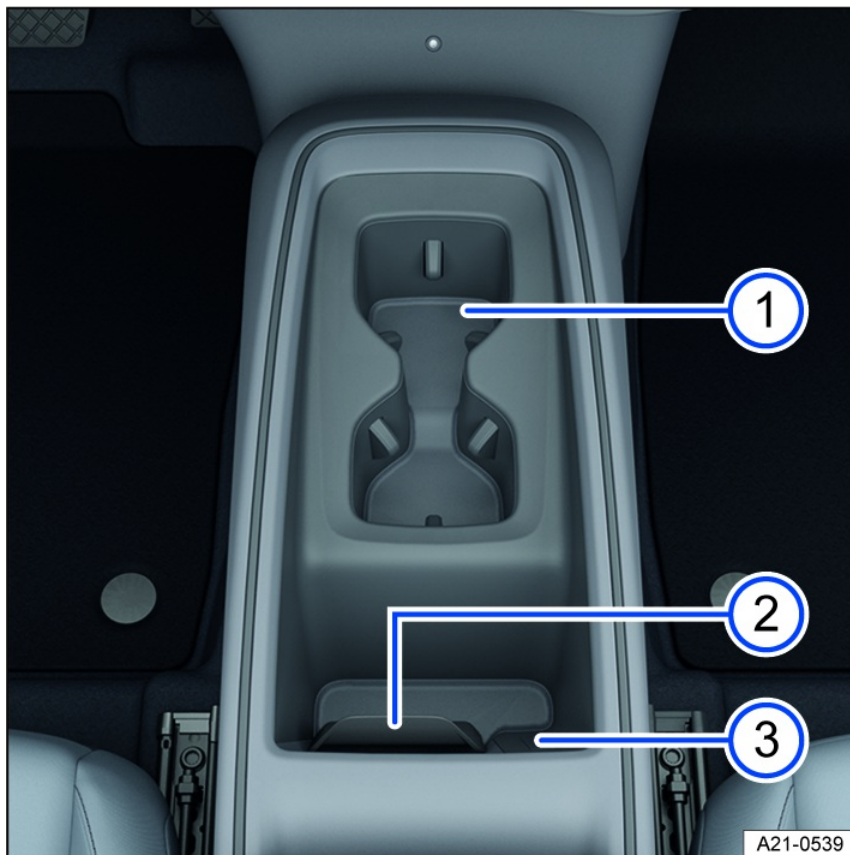



Fig. 6 Overview of the lower section of the center console.

1 Cup holders

2 Storage compartment

- with mobile phone interface ⇒  *Introduction*
- With functionality for wireless charging in accordance with Qi standard ⇒ *Charging Options for Mobile Devices*

3 USB sockets with charge function for external device rechargeable batteries (depending on the vehicle equipment) ⇒ *Wired and wireless connections,*
⇒ *Charging Options for Mobile Devices*

Passenger's side

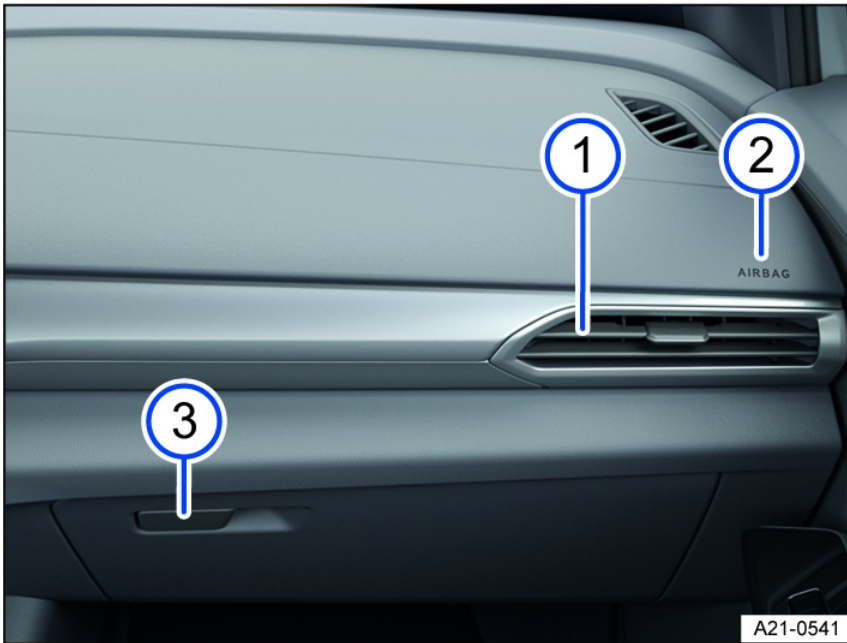

Fig. 7 Passenger's side: instrument panel overview

- ① Vent ⇒ *Air distribution and blower speed*
- ② Installation location of the front passenger's airbag in the instrument panel ⇒ *Airbag system*
- ③ Glove compartment with a button for opening

Controls in the headliner

Symbol	Meaning
	Controls for interior/reading lights ⇒ <i>Interior/reading lights, ambient lighting.</i>
	Touch panel for sunshade in the tilting and sliding panoramic sunroof ⇒ <i>Sunshade in the sunroof.</i>
	Buttons for Emergency Call, Information Call and Roadside Assistance Call ⇒ <i>Information Call, Roadside Assistance Call and Emergency Call Service.</i>

Driver information

Symbols in the instrument cluster



The warning and indicator lights can turn on individually or in combination with each other and indicate warnings, malfunctions and certain functions. Some warning and indicator lights come on when you switch the ignition on and must turn off after some time.





















Indicator lights that turn on in the light switch are described in the "Lights" chapter → [Switching the lights on and off](#).























⚠ WARNING

























Failure to respond to illuminated warning lights and messages may result in a vehicle breakdown, accidents and serious injuries or death.



- Never ignore illuminated warning lights and messages.
- Stop the vehicle as soon as it is safe to do so.

	 Do not continue driving! Central warning light → Priority 1 warning message
	Fasten safety belt → Fasten seat belts reminder and seat belt safety indicator
	High-voltage battery discharged and deep discharge possible → High-voltage battery discharged and deep discharge possible
	Holding force of the electronic parking brake too low → Electronic parking brake holding force is too low
	Electronic parking brake switched on → Electronic parking brake
PARK	Electronic parking brake switched on → Parking
BRAKE	 Do not continue driving! Brake system malfunction → Brake system malfunction , → electronic parking brake malfunction
	 Do not continue driving! Electromechanical brake booster failed → Electromechanical brake servo failure
	 Do not continue driving! Brake fluid level too low → Brake fluid level
BRAKE WEAR	Check brake system → Brake pad wear indicator
	Take over steering and be ready to brake. →  Introduction
	 Do not continue to drive! Engine coolant system malfunction → Engine coolant
	 Do not continue driving! Steering malfunction → Steering malfunction
	 Leave vehicle! Risk of fire → Risk of fire
	 Do not continue driving! Fault in high-voltage system → Fault in high-voltage system
	 Do not tow vehicle! High-voltage system overheated → Instructions for towing

	Do not continue to drive! Electric drivetrain overheated ⇒ <i>Electric drivetrain overheated</i>
	 Do not continue driving! 12 V energy supply malfunction ⇒ <i>12-volt power supply</i>
	High-voltage battery discharged – driving not possible ⇒ <i>Drive will be immediately turned off</i>
	Health risk! Open the window! CO2 concentration too high ⇒ <i>concentration in the vehicle interior is too high</i>
	Collision warning ⇒ <i>Warning levels and braking support</i>
	Take over the steering immediately ⇒ <i>Take over the steering immediately</i>
	Central warning light ⇒ <i>Priority 2 warning message</i> , ⇒ <i>The brake is too hot</i>
	Range calculation malfunction ⇒ <i>Error when calculating the range</i>
	Airbag or safety belt pretensioner system deactivated with diagnostic equipment ⇒ <i>Airbag system or safety belt pretensioners deactivated with diagnostic device</i>
	Airbag system or safety belt pretensioner malfunction ⇒ <i>Airbag system or safety belt pretensioners malfunction</i>
OFF 	Front passenger's front airbag deactivated ⇒ <i>Front passenger's front airbag switched off</i>
ON 	Front passenger's airbag enabled ⇒ <i>Front passenger's front airbag enabled</i>
	Emergency Call Service limited ⇒ <i>Emergency Call Service limited</i>
	Emergency Call Service malfunctioning ⇒ <i>Emergency Call Service malfunction</i>
	Electronic parking brake malfunction ⇒ <i>Electronic parking brake malfunction</i>
	Brake too hot ⇒ <i>The brake is too hot</i>
	Comes on: Electronic Stability Control (ESC) malfunction ⇒ <i>ESC malfunction</i>
	Flashes: Electronic Stability Control (ESC) or Anti-slip regulation (ASR) in operation ⇒ <i>Electronic Stability Control (ESC)</i>
	ESC Sport switched on ⇒ <i>ESC Sport</i>
	ASR Sport switched on ⇒ <i>ASR Sport</i>
ABS	Anti-Lock Braking System (ABS) malfunction ⇒ <i>Brake energy recuperation not possible</i> , ⇒ <i>ABS failure or malfunction</i>
	Semi-automated driving assistance (Travel Assist) not available ⇒ <i>Comfort drive Travel Assist is not available or is not working as expected</i> , ⇒ <i>Assisted lane changing is not available</i>
	Driving light failure ⇒ <i>Exterior lighting malfunction</i>
	Air conditioner is not working correctly or CO2 concentration cannot be measured ⇒ <i>concentration cannot be measured</i>

	Health risk! Open the window! CO2 concentration too high ⇒ <i>concentration in the vehicle interior is too high</i>
	Rain/light sensor malfunction ⇒ <i>Rain/light sensor malfunction</i> , ⇒ <i>Rain/light sensor malfunction</i>
	Windshield wiper malfunction ⇒ <i>Windshield wiper malfunction</i>
	Washer fluid level too low ⇒ <i>Washer fluid level too low</i>
	Steering malfunction ⇒ <i>Steering malfunction</i>
	 Do not continue to drive! Tire pressure low ⇒ <i>Tire pressure low</i>
	 Do not continue to drive! Tire pressure monitoring system malfunction ⇒ <i>Tire Pressure Monitoring System malfunction</i>
	High-voltage system malfunction ⇒ <i>Brake energy recuperation not possible</i> , ⇒ <i>High-voltage system malfunction</i>
	Reduced driving power ⇒ <i>Limited driving power</i>
	Electronic engine sound (e-Sound) malfunction ⇒ <i>Electronic engine sound failed</i>
	Autonomous Emergency Braking (Front Assist) not available ⇒ <i>Front Assist has limited availability or is not available</i>
	Autonomous Emergency Braking (Front Assist) switched off ⇒ <i>Using Front Assist</i>
	Cruise control system malfunction ⇒ <i>Cruise control system malfunction</i>
	Adaptive Cruise Control (ACC) not available ⇒ <i>ACC is not available</i>
	Emergency Assist not available ⇒ <i>Semi-automatic vehicle control in a medical emergency</i>
	Lane Keeping System (Lane Assist) not available ⇒ <i>Lane Assist not available</i>
	Semi-automatic vehicle control in a medical emergency (Emergency Assist) is functioning ⇒ <i>Driving with Emergency Assist</i>
	Lane Assist in control ⇒ <i>Driving with Lane Assist</i>
	Side Assist malfunction ⇒ <i>Side Assist malfunction</i>
	Rear Traffic Alert malfunction ⇒ <i>Rear Traffic Alert</i>
	Rear Traffic Alert brakes ⇒ <i>Rear Traffic Alert</i>
	12-volt power supply malfunction ⇒ <i>12-volt power supply</i>
	High-voltage battery charge status low ⇒ <i>High-voltage battery charge level low</i>
	High-voltage battery empty ⇒ <i>High-voltage battery has been discharged</i>
	Vehicle key not in vehicle ⇒ <i>Valid vehicle key cannot be detected</i>

	Auto Hold function active ⇒ Auto Hold
	Turn signals ⇒ Turn signal indicator light
	Trailer turn signal ⇒ Trailer turn signal indicator light
	Cruise control switched on, regulation active ⇒ Introduction
	Lane Assist active ⇒ Driving with Lane Assist
	Semi-automated driving assistance (Travel Assist) active ⇒ Introduction
	Adaptive Cruise Control (ACC) regulates, no vehicle driving ahead is detected ⇒ Switching ACC on and off
	Adaptive Cruise Control (ACC) regulates, vehicle driving ahead is detected ⇒ Switching ACC on and off
	Charging high-voltage battery ⇒ Charging
	High beams or headlight flasher ⇒ Switching the high beam headlights on and off
	Auto Hold switched on ⇒ Auto Hold
	High-voltage battery charge level ⇒ Charge status and range in the digital instrument cluster , ⇒ Charge status and range in the digital instrument cluster
	Outside temperature is below +39 °F (+4 °C) ⇒ Volkswagen Digital Cockpit information displays
	Service due ⇒ Service display
	Semi-automated driving assistance (Travel Assist) deactivated ⇒ Introduction
	Semi-automated driving assistance (Travel Assist) active, Adaptive Cruise Control active, adaptive lane guidance inactive ⇒ Introduction
	High beam control active ⇒ Switching on high beam control
	Take over the steering ⇒ Take over the steering
	Charging connector connected ⇒ Charging
	Autonomous Emergency Braking (Front Assist) starts ⇒ Front Assist starts
	Distance warning ⇒ Warning levels and braking support
	Eco driving mode ⇒ Driving mode properties
	Comfort driving mode ⇒ Driving mode properties
	Individual driving mode ⇒ Driving mode properties
	Sport driving mode ⇒ Driving mode properties

	Traction driving mode ⇒ Driving mode properties
	Note about information in the Owner's Manual ⇒ Note about information in the Owner's Manual
	Emergency charging of the high-voltage battery ⇒ Emergency charging of the high-voltage battery

Warning and information texts

The status of some functions inside the vehicle and vehicle components are checked when the ignition is switched on or while driving. Malfunctions are indicated by red and yellow warning symbols in the instrument cluster display and may also be signaled audibly in some cases. The appearance of texts and symbols may vary depending on the instrument cluster version.

Any malfunctions currently occurring can also be manually called up. To do this, open the Vehicle status or Vehicle menu ⇒ [Vehicle settings menu](#).

Priority 1 warning message

The red central warning light flashes or comes on, in some cases together with warning tones or additional symbols.  **Do not continue driving!** There is a hazard. Check the malfunction. Contact an authorized Volkswagen dealer or authorized Volkswagen Service Facility immediately for assistance.

Priority 2 warning message

The yellow central warning light flashes or comes on, in some cases together with warning tones or additional symbols. Malfunctions or insufficient operating fluids can cause vehicle damage and vehicle malfunctions. Check the malfunction as soon as possible. Immediately contact an authorized Volkswagen dealer or authorized Volkswagen Service Facility to have the system checked. Volkswagen recommends contacting an authorized Volkswagen dealer or authorized Volkswagen Service Facility.

Note about information in the Owner's Manual

You can find more information about the existing warning message in the Owner's Manual.

Informational text

Information about various processes in the vehicle.

 **If there are multiple warning messages, the symbols will appear consecutively for several seconds. The symbols will appear until the malfunction is corrected.**

 **If messages about malfunctions appear when establishing drive-ready mode, settings or information displays may not appear as described. If the malfunction persists, contact a suitably qualified professional. Volkswagen recommends contacting an authorized Volkswagen dealer or authorized Volkswagen Service Facility.**

Introduction to the instrument cluster

The vehicle is equipped with a Volkswagen Digital Cockpit. The instrument cluster shows essential information, such as speed.

In addition, the following functions, among others, are available depending on the equipment:

- Various menus, such as for the driver assistance systems.
- Status displays for the driver assistance systems.
- Display messages.
- Warning and indicator lights.
- Information about economy and range.

Content can be individually adapted and settings can be changed in the menus.

WARNING

Operating the Volkswagen Digital Cockpit and Infotainment system can distract you from traffic. If the driver is distracted while driving, accidents and serious or fatal injuries can occur.

- Always drive attentively and responsibly.
- Never operate the instrument cluster while driving.
- Only adjust any settings in the instrument cluster or Infotainment system when the vehicle is stationary.

WARNING

If there is a serious fault in the instrument cluster, the display may be turned off. The warning light  may also come on here. No further warnings can be displayed. This may result in vehicle breakdowns while driving, accidents and serious or fatal injuries.

- Safely stop the vehicle.
- See an authorized Volkswagen dealer or authorized Volkswagen Service Facility for assistance.

 After activating the vehicle's drive system when the 12 V vehicle battery is severely drained or has been replaced or jump-started, system settings, e.g. personal convenience settings and programming, may be adjusted or deleted. Check and correct the settings after the 12 V vehicle battery is sufficiently recharged.

Digital Instrument cluster

ID. Cockpit

The ID. cockpit is a Volkswagen Digital Cockpit with a high-resolution LCD color display. By selecting different information profiles, you can display notifications from the driver assistance systems and other notifications, as well as the digital speedometer. The term "Volkswagen Digital Cockpit" is used for the ID. cockpit below.



Fig. 8 Digital instrument cluster in the instrument panel (general example).

Operating the Volkswagen Digital Cockpit



Fig. 9 Right side of the multi-function steering wheel: operating the Volkswagen Digital Cockpit.

Views in the display

Information and warnings are displayed as events in the digital instrument cluster. The event pops-up from the top of the digital instrument cluster screen and is hidden again after a certain time.

The different views offer you a better overview of the vehicle data, navigation or information about the driver assistance system.

Depending on the vehicle equipment, the amount of information shown and the scope thereof may vary.

The digital instrument cluster can display the following views:

Summary Before establishing drive-ready mode: display with information about mileage, battery charge level and range.

Basic Driving displays with information about driver assistance systems, speed and navigation.

Driver assistance systems Display of the active driver assistance systems and the speed. The navigation context is hidden.

Navigation Display with notes on route guidance and speed. The graphical view of the driver assistance systems is hidden.

 **Situation-related messages, such as navigation information, are shown as pop-ups.**

Setting views

You can select the “driver assistance systems” view and the “navigation” view using the **VIEW** button on the multi-function steering wheel.

- Press the **VIEW** button in the right-hand section or swipe to the right over the button to change to “Navigation” view.
- Press the **VIEW** button in the left-hand section or swipe to the left over the button to change to “Driver assistance systems” view.

 **If warning messages about malfunctions appear when the ignition is switched on, settings or information displays may not appear as described. If the malfunction persists, contact a suitably qualified professional. Volkswagen recommends contacting an authorized Volkswagen dealer or authorized Volkswagen Service Facility.**

WARNING

Operating the instrument cluster and the Infotainment system can distract from traffic. If the driver is distracted while driving, accidents and serious or fatal injuries can occur.

- Always drive attentively and responsibly.
- Never operate the instrument cluster while driving.
- Only adjust any settings in the instrument cluster or Infotainment system when the vehicle is stationary.

Volkswagen Digital Cockpit information displays

Possible displays in the digital instrument cluster

Depending on the vehicle equipment, different information may be shown in the Volkswagen Digital Cockpit:

- Outside temperature display.
- Detected road sign from the traffic sign recognition.
- Open doors, hood and trunk lid.
- Speed warnings.
- Speed warning for winter tires.
- Odometer displays.
- Navigation information.
- Range display.
- Remaining charging time for the high-voltage battery ⇒ *Charging process indicator*.
- Service display.
- Warning and information texts.

Outside temperature display

When outside temperatures are colder than about +4 °C (+39 °F), a snowflake symbol ❄ also appears in the digital instrument cluster from above. This symbol remains on until the outside temperature rises above +6 °C (+43 °F).

In the following situations, the temperature displayed may be higher than the actual outside temperature due to heat radiating from the vehicle:

- When the vehicle is stationary
- When the driving speed is very low

The measurement range is from -45 °C (-49 °F) to +76 °C (+169 °F)

WARNING

Roads may be icy at low outside temperatures, even above the freezing point. On icy roads, there is an increased risk of accident. This could result in serious or fatal injuries.

- If the ❄ symbol appears in the instrument cluster display, drive with particular care.

- Always adapt your speed and driving style to the visibility, weather, road and traffic conditions.
- Never rely solely on the outside temperature display.

Open doors, hood and trunk lid

If, after unlocking the vehicle and while driving, any doors and/or the hood or trunk lid are open, this is displayed in the Volkswagen Digital Cockpit and an audible signal may also sound.

Speed warning for winter tires

If the set maximum speed is exceeded, this will be shown in the digital instrument cluster.

Settings for the speed warning can be adjusted in the vehicle settings in the Infotainment system → [Vehicle settings menu](#).

Odometer displays

The odometer registers the total distance that the vehicle has driven.

Range display

The approximate distance in kilometers which can still be driven with the remaining battery capacity, if driven in the same manner and with the same energy consumption. The calculation is based on the current energy consumption.

 Some displays in the Volkswagen Digital Cockpit may be hidden due to events that occur suddenly, e.g. speed warnings.

 Depending on the equipment, some settings and displays may also appear in the Infotainment system.



e-Displays

Charge status and range in the digital instrument cluster

Charge status display



Fig. 10 In the Volkswagen Digital Cockpit: The high-voltage battery charge level  and vehicle range  (general example).

The current battery charge level of the high-voltage battery is shown by the  symbol with a percentage value in the Volkswagen Digital Cockpit [fig. 10](#). The battery level on the symbol changes with the charge status.

Range display

The vehicle range is displayed in kilometers (km) or miles (mi), depending on the setting [fig. 10](#).

The value displayed is calculated and updated according to your driving style and the environmental conditions. Therefore, the range can vary even with a fully charged high-voltage battery.

Reserve range

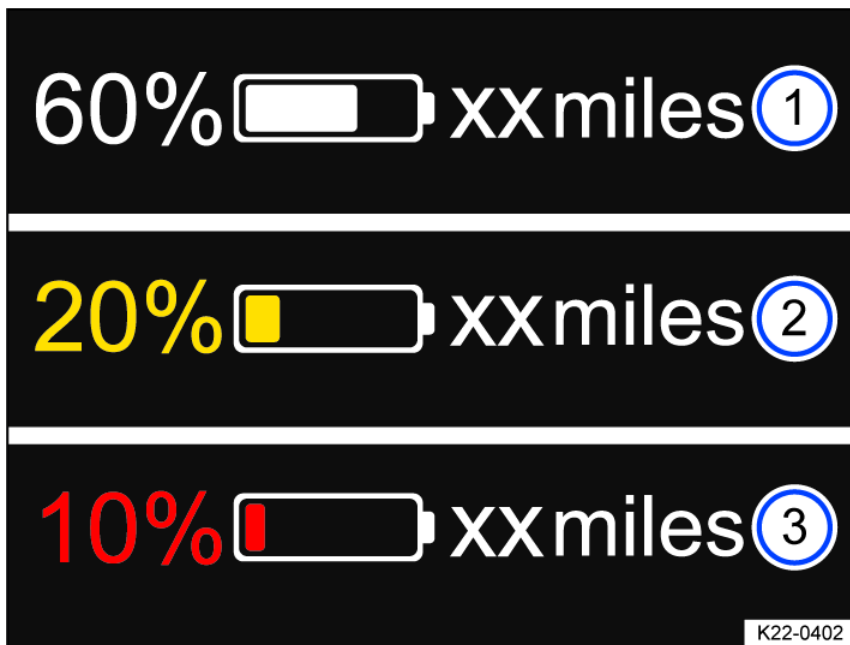

Fig. 11 In the digital instrument cluster: Range and reserve display.

- ① Battery charge level and range
- ② Reserve display warning level 1 and range.
- ③ Reserve display warning level 2 and range.

Warning levels for the reserve range :

Yellow The charge status is equal to 20 % or less than 20 % *fig. 11.*

Red The charge status is equal to 10 % or less than 10 % *fig. 11.*

Charge the high-voltage battery as soon as possible to prevent vehicle breakdowns *fig. 11!*

WARNING

Driving with the high-voltage battery low on charge could lead to breakdowns in road traffic, accidents and serious or fatal injuries.

- Always ensure your high-voltage battery has a sufficient battery charge level.

WARNING

If the charge level of the high-voltage battery has reached the reserve charge level, the handling characteristics, e.g. the acceleration behavior, of the vehicle may be altered. This can cause accidents and serious injuries.

- Always adapt your speed and driving style to the current visual, weather, road, and traffic conditions, as well as the charge level of the high-voltage battery.
- Always ensure your high-voltage battery has a sufficient battery charge level.

NOTICE

Self-discharging of the high-voltage battery, for example due to a long stationary period of several months, may damage the high-voltage battery in high ambient temperatures and with a low battery charge level.

- Always ensure your high-voltage battery has a sufficient battery charge level.

In very low outside temperatures, when the high-voltage battery is very cold, you may experience a limited range for electric driving.

Power display

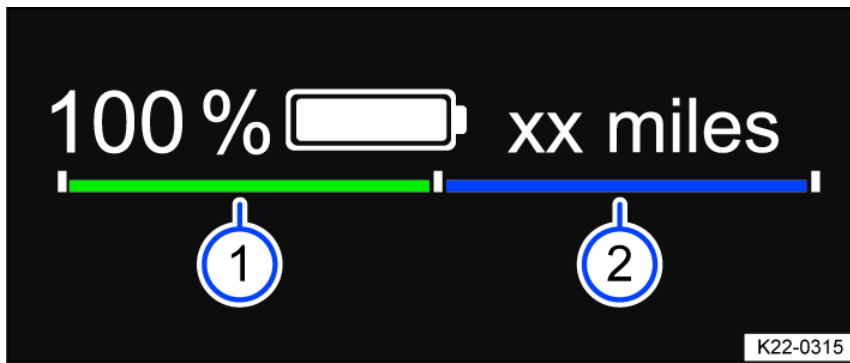

Fig. 12 In the Volkswagen Digital Cockpit: Power display (general example).

During travel, the power display shows the current performance of the electric drivetrain and the current electric drive power or energy recuperation power.

Display concept

Using a bar split down the middle, the power display always shows the availability of energy recuperation [fig. 12](#) ¹ (green) to the left and forward motion [fig. 12](#) ² (blue) to the right. If the respective bar reaches to the end marking, there is unlimited availability. If there is any restriction, the bar is shown as correspondingly shortened.

The current drive power is displayed dynamically using a lighter bar, either as recuperation power (light green) to the left or as propulsive power (light blue) to the right.

If current drive power and currently available performance are equal in size (bars equal in length), the power limit of the electric drivetrain has been reached.

 **The power limit cannot be reached at all vehicle speeds.**

Influencing factors

In addition to vehicle speed, the following influencing factors exist:

- The availability of forward motion and energy recuperation depends on the battery charge level of the high-voltage battery. The energy recuperation can be limited if the battery charge level is high, as can the forward motion if the battery charge level is low.
- The high-voltage battery being at a very low or very high temperature can lead to a decrease in the available drive power. This affects forward motion and energy recuperation.

WARNING

If the drive power of the electric drivetrain is reduced, the handling characteristics, e.g. the acceleration behavior, of the vehicle may be altered. This can cause accidents and serious injuries.

- Always adjust your speed and driving style to the current visibility, weather, road, and traffic conditions, and to the battery charge level of the high-voltage battery.
- Always ensure your high-voltage battery has a sufficient battery charge level.

ID. Light

ID. Light is an intelligent lighting concept that shows you further information about your vehicle status. When the vehicle's drive system is activated and while driving, information about the current driving situation is displayed via the ID. Light.

The ID. Light shows information and warnings of the following systems and functions:

- Locking and unlocking.
- Entry and exit lighting.
- Charging processes.
- Voice operation.
- Telephone calls.
- Navigation
- Reduced driving power.
- Brief interruptions to operation.
- Steering wheel contact detection.

- Park Assist Plus.
- Adaptive Cruise Control (ACC)
- Autonomous Emergency Braking (Front Assist).

 Some of the selection options shown in the submenu have no function.

 You can change and expand which information is displayed by running an over-the-air update.

Brightness

1. Tap the **(Vehicle)** function key in the Infotainment system.
2. Select display content for Inside. Then tap the **(ID. Light)** function key.
3. Set the brightness with the touch control.
4. Tap the home button  to return to the previous menu.

Settings in the Infotainment system

Certain ID. Light functions can be activated or deactivated in the vehicle settings in the Infotainment system.

The activated functions are highlighted in color.

1. Tap the home button  to return to the previous menu.

Service

Service menu

Opening the Service Menu

1. Tap the Vehicle function key in the Infotainment system.
2. Tap the Status function key.
3. Tap the Service function key to display the service information.

The activated functions are highlighted in color.

The mileage and the days to the next inspection service will be displayed.

4. Tap  to return to the previous menu.

Resetting the trip odometer

1. Tap the Vehicle function key in the Infotainment system.
2. In the Vehicle menu, tap the Status function key.
3. Tap the Distance driven function key.
4. Tap the **(0.0)** function key to reset the value.

Displaying the Vehicle Identification Number (VIN)

1. Tap the Vehicle function key in the Infotainment system.
2. In the Vehicle menu, tap the Status function key.
3. To display the vehicle identification number (VIN), tap the Service function key.

The vehicle identification number (VIN) is displayed.

Service display

Displays about service events appear in the Volkswagen Digital Cockpit and in the Infotainment system.

Service notification

If an inspection service is due in the near future, a service reminder will be displayed when you switch on the ignition.

The specified mileage or time is the distance or time that can be driven until the next inspection service.

One of the following displays may appear:

- Inspection service in xx miles.
- Inspection service in xx days.

Service event

When an inspection service is due, a warning chime will sound and a wrench symbol  may appear on the Volkswagen Digital Cockpit for a few seconds, together with the following indicator, when you switch on the ignition:

- Please have an inspection service performed

Checking a service interval in the Infotainment system

1. Tap the Vehicle function key.
2. Tap the Status function key.
3. Tap the Service function key to display the service information.

The activated functions are highlighted in color.

The mileage and the days to the next inspection service will be displayed.

Resetting the service display

The service display can only be reset as part of an inspection service by suitably qualified professionals. Volkswagen recommends contacting an authorized Volkswagen dealer or authorized Volkswagen Service Facility.

 The service message disappears automatically after a few seconds when the vehicle has been made drive-ready or when the **OK** button on the multi-function steering wheel is pressed.

Time and date

Setting the time and date in the Infotainment system

1. Tap the **Settings** function key ⇒ *Vehicle settings menu*.
2. Select the **Time and date** menu item.

 The time and date are only displayed in the Infotainment system.

Exit menu

You can adjust the settings of some functions in the exit menu before leaving the vehicle. The exit menu will be displayed in the Infotainment system when you switch off the ignition.

The entries shown depend on the vehicle equipment and may only be available under certain conditions. The adjustable functions include, for example:

- Charging the high-voltage battery.
- Stationary air conditioning



Hide

The exit menu is automatically hidden when you leave the vehicle. The exit menu will also be hidden after a short time, depending on the vehicle equipment.

1. To hide the exit menu manually, tap .

Settings

You can adjust the order of the entries shown.

1. Tap .
2. Reorder entries as required.
3. Tap  again.

Vehicle settings menu

You can switch individual functions and systems on and off and adjust settings in the vehicle settings menu in the Infotainment system.

Opening the Vehicle settings Menu

1. Switch the ignition on.
2. If necessary, switch on the Infotainment system.
3. Tap the **Vehicle** function key.
4. Depending on the equipment: Tap the **Vehicle** menu item and choose between the **Interior** and **Exterior** function keys.
Or: select the  menu item.
5. Open the preferred item from the submenus and set as desired.

System settings and vehicle information display

Depending on the version, information can be displayed or settings set in the Vehicle settings menu:

- Depending on the vehicle equipment: 3D vehicle view (Interior or Exterior).
- Depending on vehicle equipment: Performance monitor.

- Depending on vehicle equipment: Lap timer.
- Driving Data.
- Vehicle status.

! After activating the vehicle's drive system when the 12 V vehicle battery is severely drained or has been replaced or jump-started, system settings, e.g. personal convenience settings and programming, may be adjusted or deleted. Check and correct the settings after the 12 V vehicle battery is sufficiently recharged.

⚠ WARNING

If the driver is distracted, accidents and serious injuries can occur. Operating the Infotainment system can distract you from traffic.

- Always drive attentively and responsibly.
- Adjust settings in the Infotainment system only when the vehicle is stationary.

Dynamic Road Sign Display

📖 Introduction

The Dynamic Road Sign Display detects standard road signs using a camera in the interior rearview mirror base and informs the driver of detected speed limits and passing restrictions. Within the system limits, the system also displays an additional sign to indicate special restrictions. The system may also continue to display the valid speed limit on roads without signs.

The traffic signs recorded by the Dynamic Road Sign Display are shown in the display of the Volkswagen Digital Cockpit. Depending on the Infotainment system installed in the vehicle, the road signs may also be displayed there.

Dynamic Road Sign Display is always active when the ignition is started.

Road sign display

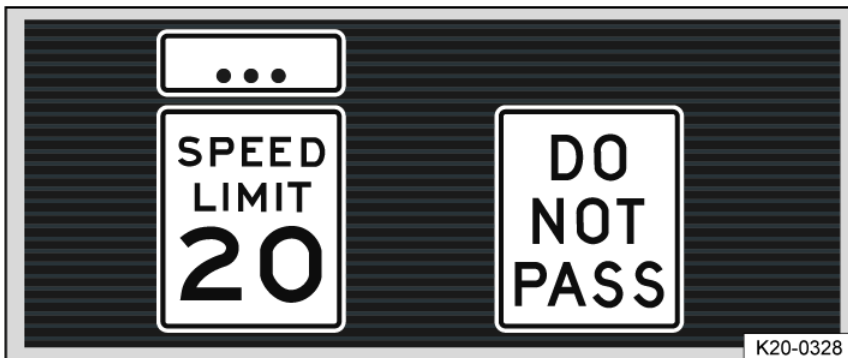

Fig. 13 In the instrument cluster display: Example of detected speed limits.

After checking and evaluating the information from the camera, the Infotainment system, and the current vehicle data, the Dynamic Road Sign Display function displays up to two valid traffic signs and a generic additional sign [fig. 13](#):

1st position: The traffic sign that currently applies is shown on the left side of the display, for example a speed limit of 20 mph (35 km/h).

2nd position: Another road sign can be displayed in the second position, such as a passing restriction.

Additional signs: A recognized additional sign is displayed above the applicable traffic sign. Depending on the system, a generic additional sign is displayed instead of the actually recognized additional sign. The applicable traffic sign in the display of the instrument cluster is supplemented by the generic additional sign.

⚠ WARNING

The Dynamic Road Sign Display is not a replacement for the driver's attention and works only within the system limitations. Consequently, the Dynamic Road Sign Display cannot detect all road signs and may not react, or may react with a delay, or may react in a way that is not desired. Driving recommendations and road signs displayed in the Dynamic Road Sign Display may differ from the actual traffic situation.

- Observe the system limitations ⇒ [Limits of the Dynamic Road Sign Display](#).
- Always stay attentive and do not rely solely on the system. The driver is always responsible for control of the vehicle.
- Traffic signs on the roads and traffic regulations must always take precedence over driving recommendations and displays from the Dynamic Road Sign Display function.
- Always adapt your speed and driving style to the visibility, weather, road and traffic conditions.

Limits of the Dynamic Road Sign Display

 Please read the introductory information and heed the Warnings and Notice ⇒  [Introduction](#).

Error messages

No road signs available. The system is in the initialization phase.

Or: the vehicle has not detected any road signs.

Error: Dynamic Road Sign Display. System malfunction. If the malfunction persists, contact a suitably qualified professional. Volkswagen recommends contacting an authorized Volkswagen dealer or authorized Volkswagen Service Facility.

Speed Alert currently not available. The speed alert from the Dynamic Road Sign Display is malfunctioning. If the malfunction persists, contact a suitably qualified professional. Volkswagen recommends contacting an authorized Volkswagen dealer or authorized Volkswagen Service Facility.

Dynamic Road Sign Display: Clean windshield! The windshield is dirty in the area around the camera or weather conditions are interfering with the camera view. Clean the windshield.

Dynamic Road Sign Display is currently limited. Data is not being transmitted by the Infotainment system. Check that valid map data is loaded in the Infotainment system.

Or: The vehicle is located in an area that is not detected on the map stored in the Infotainment system.

No data available. The Dynamic Road Sign Display function is not supported in the country where the vehicle is currently being operated.

Functional limitations

The Dynamic Road Sign Display is subject to system limitations. The following conditions may cause the Dynamic Road Sign Display function to be limited or to not operate at all:

- High ambient temperature or long exposure to direct sunlight.
- Poor visibility, such as in snow.
- Glare, for example from oncoming traffic or the sun
- High speeds
- If the camera is obstructed or dirty
- If road signs are outside of the camera's visual field
- If road signs are partially or completely covered, for example by trees, snow, dirt, or other vehicles.
- If road signs are not in the standard format
- If there are damaged or bent road signs
- If there are variable traffic signs on overhead signs (variable display of road signs by LED s or other lighting).
- If there is outdated map material in the Infotainment system
- If there are stickers on vehicles that indicate road signs, such speed limits on commercial vehicles

Operating the Dynamic Road Sign Display

 Please read the introductory information and heed the Warnings and Notice ⇒  [Introduction](#).

Speed warning

If the Dynamic Road Sign Display function detects that a valid speed limit is being exceeded, it may warn the driver audibly, or visually and audibly, with a message in the instrument cluster display.

The speed warning can be set or completely deactivated in the Infotainment system ⇒ [Vehicle settings menu](#). The speed warning can be set to a value of 0 mph (0 km/h), 3 mph (5 km/h) or 5 mph (10 km/h) over the permitted speed.

Trailer mode

On vehicles with a trailer hitch installed at the factory and a trailer that is connected to the vehicle electrical system, the display of road signs relevant to a trailer, such as the valid speed limit and passing restrictions for vehicles with a trailer, can be activated and deactivated in the vehicle settings in the Infotainment system ⇒ [Vehicle settings menu](#).

For trailer mode, the display of valid speed limits can be adjusted to the model of the trailer and to the legal regulations. The setting can be set in increments of 10 km/h (5 mph) within a range of approx. 60 km/h (35 mph) and approx. 130 km/h (80 mph). If a speed is set that is higher than the permitted speed for driving with a trailer in the country or state where the vehicle is being operated, the Dynamic Road Sign Display function will automatically display the legal speed limit, for example approx. 80 km/h (50 mph) in California.

Safety

General information

Driving preparations and driving safety

Observe the following points before and during every trip, for your own safety and for the safety of your passengers and others on the road ⇒ :

- ✓ Make sure the vehicle lighting and turn signals are functioning correctly.
- ✓ Check the tire pressure and charge level ⇒ *Checking the tire pressure*, ⇒ *Charging process indicator*.
- ✓ Check the washer fluid level ⇒ *Washer fluid*.
- ✓ Ensure that the windows are clear and provide good visibility ⇒ *Exterior care and cleaning*.
- ✓ The air flow to the electric drivetrain must not be blocked and the electric drivetrain must not be covered by covers or insulation ⇒ *Safety precautions for working in the hood space*.
- ✓ Secure all objects and luggage in the storage compartments and the luggage compartment ⇒ *Transporting*.
- ✓ It must be possible to press the pedals without interference.
- ✓ Secure children with child restraint systems that are appropriate for their weight and height ⇒ *Transporting children safely*.
- ✓ Adjust the front seats, head restraints, and mirrors according to the size of the occupants ⇒ *Seating position*, ⇒ *Mirrors*.
- ✓ Wear shoes that give your feet good grip for operating the pedals.
- ✓ The floor mat in the driver side footwell must be kept clear from the pedal area and be secured.
- ✓ Assume the correct seating position before driving and remain that way while driving. This also applies to all passengers ⇒ *Seating position*.
- ✓ Fasten the safety belt correctly before you begin driving and keep it fastened while driving. This also applies to all passengers ⇒ *Safety belts*.
- ✓ The number of passengers must not exceed the number of seats and safety belts.
- ✓ Never drive when impaired, for example by medication, alcohol, or drugs.
- ✓ Never allow yourself to be distracted from traffic, such as by adjusting settings, by opening menus, by passengers, or by phone calls.
- ✓ Always adapt your speed and driving style to the current visual, weather, road, and traffic conditions.
- ✓ Follow driving rules and posted speed limits.
- ✓ Take regular breaks on long trips. You should take a break at least every two hours.
- ✓ Secure animals in the vehicle restraint systems that are appropriate for their weight and size.

Driving in other countries

Some countries have special safety standards and regulations that differ from the vehicle configuration. Volkswagen recommends that you inform yourself about legal regulations and about the following points from an authorized Volkswagen dealer or authorized Volkswagen Service Facility before driving in other countries.

Volkswagen recommends contacting an authorized Volkswagen dealer or authorized Volkswagen Service Facility.

- ✓ Do technical modifications need to be made to the vehicle before driving in other countries, such as covering or adjusting the headlights?
- ✓ Are the tools, diagnostic equipment, and replacement parts that are needed for maintenance and repair work available?
- ✓ Is there an authorized Volkswagen dealer or authorized Volkswagen Service Facility in the country where you will be driving?
- ✓ Are fluids that meet Volkswagen specifications available in the country where you will be driving ⇒ *Operating fluids and operating equipment*?
- ✓ Will the navigation function in the factory-installed Infotainment system work with the existing navigation data in the country where you will be driving?
- ✓ Are special tires needed in the country where you will be driving?
- ✓ Is a fire extinguisher required in the country where you will be driving?
- ✓ What are the requirements for a safety vest?
- ✓ Does the country you are traveling to require a special charging cable?

Checks when charging

Never carry out work on the high-voltage system yourself! Only perform work in the hood space if you are familiar with the necessary steps and the general safety precautions, and if the correct operating equipment, fluids, and suitable tools are available ⇒ *Safety precautions for working in the hood space*. Have all work performed by suitably qualified professionals. Volkswagen recommends contacting an authorized Volkswagen dealer or authorized Volkswagen Service Facility.

Make sure that the following items are checked regularly:

- ✓ Washer fluid level ⇒ *Washer fluid*.
- ✓ Engine coolant level ⇒ *Engine coolant*.
- ✓ Brake fluid level ⇒ *Brake fluid specifications*.
- ✓ Tire inflation pressure ⇒ *Checking the tire pressure*.
- ✓ Vehicle lighting ⇒ *Headlights* which is necessary for traffic safety:

DANGER

Read and heed the important safety instructions for the front passenger's front airbag ⇒ [Safety notes on using child restraints](#).

DANGER

The voltage in the high-voltage system is dangerous may will cause burns, other injuries, and fatal electric shocks.

- Read and heed the important safety information about the high-voltage system and the high-voltage battery ⇒ [Safety instructions](#).

WARNING

Alcohol, drugs, medication, and prescription narcotics can considerably impair perception, reaction times, and driving safety, which can result in loss of vehicle control. This can cause accidents and serious or fatal injuries.

- Do not drive under the influence of alcohol, drugs, medication or prescription narcotics.

WARNING

Not paying attention to road traffic can cause accidents and serious or fatal injuries.

- Always comply with the applicable driving regulations and speed limits and think ahead while driving.
- Take regular breaks on long drives. You should take a break at least every two hours.

NOTICE

Volkswagen is not responsible for damage to the vehicle caused by substandard fuel, insufficient maintenance, or unsuitable replacement parts.

- Volkswagen recommends the use of Volkswagen original parts or Volkswagen original accessories, which you can acquire from an authorized Volkswagen dealer or authorized Volkswagen Service Facility.

 **Having the vehicle serviced regularly not only maintains the value of the vehicle, but also contributes to operational safety and roadworthiness. Therefore, have maintenance procedures performed according to Volkswagen instructions. Under extreme operating conditions, some work may need to be performed before the next service is due. Extreme operating conditions can include frequent "stop-and-go" driving or driving in areas with a lot of dust in the air. For further information, contact an authorized Volkswagen dealer or authorized Volkswagen Service Facility. Volkswagen recommends contacting an authorized Volkswagen dealer or authorized Volkswagen Service Facility.**

Seating position

Introduction

Number of seats

The vehicle has a total of five seats: two seats in the front and three seats in the back.

Every seat is equipped with a safety belt.

WARNING

Sitting incorrectly in the vehicle can increase the risk of serious or fatal injuries during sudden driving or braking maneuvers, in the event of a collision or accident, and if the airbags are deployed.

- Before the vehicle starts to move, all vehicle occupants must always be in the correct seating position and maintain it while driving. Safety belts must also be fastened and remain fastened.
- The number of persons in the vehicle must not exceed the number of seats with safety belts.
- Always secure children in the vehicle with an approved and suitable child restraint system according to the child's body size and weight ⇒ [Transporting children safely](#) and ⇒ [Airbag system](#).
- Always keep feet in the footwell while driving. For example, never rest feet on the seat or on the instrument panel and never hold feet out of the window. Otherwise, if the airbag and the safety belt deploy, they could increase the risk of injury in the event of an accident instead of providing protection.

Risk of injury due to an incorrect seating position

 **Please read the introductory information and heed the Warnings and Notice ⇒ [Introduction](#).**

The risk of serious or fatal injuries will increase if safety belts are not worn or are incorrectly fastened. Safety belts can only achieve the optimum protection if they

are routed correctly. An incorrect seating position significantly impairs the protective function of the safety belt. This could result in serious or fatal injuries. The risk of serious or fatal injuries increases even more if a deployed airbag strikes a passenger who is sitting in an incorrect seating position. The driver is responsible for all vehicle occupants and especially for children who are being transported in the vehicle.

The following list includes examples of seating positions that could be dangerous for all vehicle occupants.

The following points always apply when the vehicle is in motion:

- Never stand inside the vehicle.
- Never stand on the seats.
- Never kneel on the seats.
- Never tilt your seat backrest too far back.
- Never lean against the instrument panel.
- Never lay down in the seats in the vehicle interior or on the rear bench seat.
- Never sit only on the front section of the seat.
- Never sit sideways on the seat.
- Never lean against the window.
- Never place your feet out of the window.
- Never place your feet on the instrument panel.
- Never place your feet on the seat cushion or on the seat backrest.
- Never ride in the footwell.
- Never sit on the armrests.
- Never drive or ride in a seat without fastening your safety belt.
- Never ride in the trunk.

⚠ WARNING

Incorrect seating positions in the vehicle increase the risk of serious or fatal injuries in the event of an accident or sudden driving and braking maneuvers, especially if the airbags are deployed and exert force on a vehicle occupant who is not sitting correctly.

- All vehicle occupants must always sit in the correct seating position and have their own safety belts correctly fastened while driving.

Correct seating position

📖 Please read the introductory information and heed the Warnings and Notice ⇒ ⚠ Introduction.

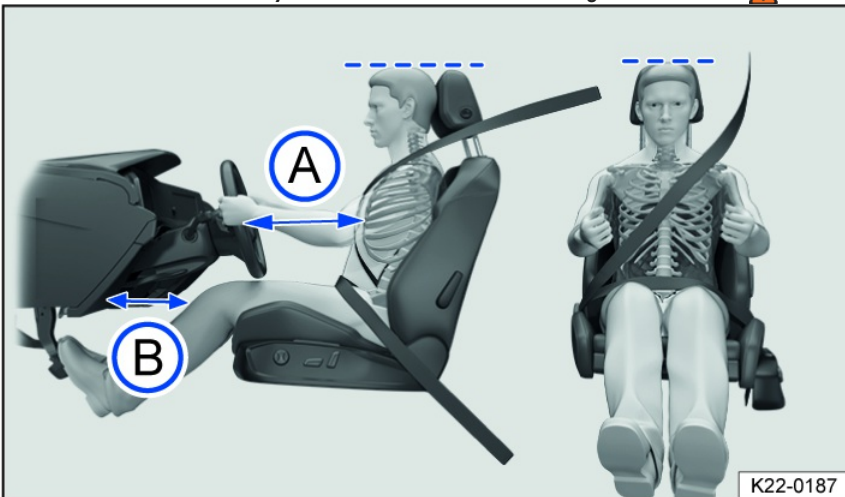

Fig. 14 General example: correct distance between the driver and the steering wheel, correct safety belt routing and correct head restraint adjustment.

The correct seating positions for the driver and passengers are specified in the information that follows. The safety belt and airbags only provide the optimum protection when vehicle occupants are seated in a correct seating position.

If you have a physical impairment that prevents you from sitting correctly on the driver seat with a correctly worn safety belt and reaching the pedals, special modifications to your vehicle may be necessary. For information on possible changes to your vehicle, contact an authorized Volkswagen dealer or authorized Volkswagen Service Facility qualified for this. Volkswagen recommends contacting an authorized Volkswagen dealer or authorized Volkswagen Service Facility. Alternatively, contact the Volkswagen Customer CARE Center at +00 (1) 800 822 8987.

For your safety and to reduce the risk of injuries in the event of a sudden braking maneuver or accident, Volkswagen recommends the following seating positions:

The following applies to all vehicle occupants:

- Adjust the head restraint so that the upper edge of the head restraint is in line with the upper portion of the head as much as possible, but not lower than eye level. Position the back of the head as close as possible to the head restraint *fig. 14*.
- For shorter individuals, slide the head restraint all the way downward, even if the head is then below the upper edge of the head restraint.
- For taller individuals, move the head restraint upward all the way.
- Keep both feet in the footwell while driving.
- Adjust and fasten the safety belts correctly ⇒ *Safety belts*.

The following additional points apply to the driver:

- Adjust the forward/back position of the driver seat so that you can press the pedals while your legs are slightly bent and there is at least 10 cm (around 4 inches) of space between the instrument panel and your knees *fig. 14*.
- Adjust the driver seat so that the top point of the steering wheel can be reached.
- Position the seat backrest in an upright position, so that your back rests completely on the seat backrest.
- Adjust the steering wheel so that the distance between the steering wheel and your chest is at least 25 cm (around 10 inches) *fig. 14* and you can hold the steering wheel firmly at the sides with both hands and your elbows slightly bent.
- When adjusted, the steering wheel must always face your chest and not be directed toward your face.
- In vehicles with head restraints that can be moved forward or back, position the head restraint so that it is as close as possible to the back of the head.
- Always keep both feet in the footwell to keep control of the vehicle at all times.

The following additional points apply to the front passenger:

- In vehicles with head restraints that can be moved forward or back, position the head restraint so that it is as close as possible to the back of the head.
- Position the seat backrest in an upright position, so that your back rests completely on the seat backrest.
- Move the front passenger seat back as far as possible so that the airbag can provide optimum protection if it deploys.

Safety belts

Introduction

Check the condition of all of the safety belts regularly. If there is damage to the belt fabric, the belt connections, the automatic safety belt retractor or the buckle, have the affected safety belt replaced immediately by suitably qualified professionals ⇒ . The authorized Volkswagen dealer or authorized Volkswagen Service Facility must use the correct parts for the vehicle, equipment and model year. Volkswagen recommends contacting an authorized Volkswagen dealer or authorized Volkswagen Service Facility.

WARNING

The risk of serious and fatal injuries increases if the safety belts are not worn or are worn incorrectly.

- Safety belts are the most effective way to reduce the risk of serious and fatal injuries in a collision. Before every trip, vehicle occupants must therefore seat themselves correctly, fasten the safety belt that belongs to the seat they are using, and keep it fastened while the vehicle is in motion. This applies to all passengers and at all times, including during city driving.
- Secure only one person with a safety belt.
- Secure children in the vehicle with a child restraint that is appropriate for their weight and height and with the safety belt used correctly ⇒ *Transporting children safely*.
- Never allow children or infants to ride on anyone's lap and never strap children or infants to another person with the same safety belt.
- Only ever insert and latch the buckle tongue in the belt buckle for the corresponding seat. Using a buckle from another seat reduces the protection provided by the safety belt and can cause serious injuries.
- Do not wear extremely bulky, loose clothing in the vehicle, such as a coat over a sports jacket, because this could impair the fit and function of the safety belt.

WARNING

If the belt webbing or other parts of the safety belts are damaged, the safety belts could tear during a collision or sudden braking maneuver and cause serious or fatal injuries.

- Never damage the safety belts by trapping them or chafing them on sharp edges.
- Have damaged safety belts replaced immediately with new safety belts that are approved for the vehicle by Volkswagen. Safety belts that are stretched during a collision must be replaced by an authorized Volkswagen dealer or authorized Volkswagen Service Facility. Volkswagen recommends contacting an authorized Volkswagen dealer or authorized Volkswagen Service Facility. It may be necessary to replace them even if there is no visible damage. Check the safety belts' anchorage points as well.
- Never try to repair, modify, or remove the safety belts yourself. Have all repairs to safety belts, safety belt retractors, and buckle components performed only by an authorized Volkswagen dealer or authorized Volkswagen Service Facility. Volkswagen recommends contacting an authorized Volkswagen

Fasten seat belts reminder and seat belt safety indicator

📖 Please read the introductory information and heed the Warnings and Notice ⇒ ⚠️ Introduction.



Fig. 15 In the instrument cluster display: warning light.

⚠️ The driver or front passenger has not fastened their safety belt. Fasten all safety belts.

When the ignition is switched on, several warning and indicator lamps light up temporarily as a function check. They then turn off after a few seconds.

A chime also sounds.

When the ignition is switched on, the red ⚠️ warning light comes on for six seconds. A chime also sounds for up to six seconds if the driver safety belt is not fastened. The chime ends when the driver fastens their safety belt. The warning lamps and chime go off when the driver and front passenger have fastened their safety belts.

If the driver and front passenger do not both fasten their safety belts within 10 seconds after the warning chime has ended and the vehicle is driving at a speed above approx. 25 km/h (approx. 15 mph), the chime sounds again for approx. 6 seconds, then stops for approx. 24 seconds, and then sounds again for approx. 6 seconds. The same happens if one of the safety belts is released while driving. The red ⚠️ warning light comes on. A warning chime also sounds for up to two minutes at 24-second intervals. The chime does not sound at speeds below approx. 8 km/h (approx. 5 mph).

When the ignition is switched on, the red ⚠️ warning light comes on until the driver and front passenger have both fastened their safety belts.

⚠️ WARNING

The risk of serious and fatal injuries increases if the safety belts are not worn or are worn incorrectly.

- Fasten the safety belts and use them correctly to ensure that they provide optimum protection.

Using safety belts

📖 Please read the introductory information and heed the Warnings and Notice ⇒ ⚠️ Introduction.

Checklist

Using safety belts ⇒ ⚠️:

- ✓ Check the condition of all of the safety belts regularly.
- ✓ Keep safety belts clean.
- ✓ Always keep foreign objects and fluids far away from the safety belt, the safety belt buckle, and the slot in the safety belt buckle.
- ✓ Do not pinch or damage the safety belt and/or belt buckle, for example closing it in a door.
- ✓ Never remove, modify, or repair the safety belt and belt fastening elements.
- ✓ Always fasten the safety belt correctly before you begin driving and keep it fastened while driving.

Twisted safety belt

If the safety belt is difficult to pull out of the belt guide, the safety belt may have been pulled out too quickly when positioning the belt and may have become twisted within the side trim panel:

1. Slowly and carefully pull the safety belt out completely by the belt buckle.
2. Untwist any twisted sections of the safety belt and guide the belt back slowly by hand.

If you cannot untwist the safety belt, fasten the safety belt anyway. The twist must not be in a section of the belt that rests directly on the body. Go to an authorized Volkswagen dealer or authorized Volkswagen Service Facility immediately to have the belt untwisted. Volkswagen recommends contacting an authorized

Volkswagen dealer or authorized Volkswagen Service Facility.

Lockable safety belt

The safety belts on the rear seats and the safety belt on the front passenger seat are lockable and have an emergency locking function. With the locking function, you can adjust the safety belt so that a child restraint is properly installed ⇒ [Securing a child restraint with a safety belt](#) .

Safety belts may only be locked for certain child restraint systems ⇒ [Child restraints – overview](#) .

An activated locking mechanism must be released when a vehicle occupant fastens their safety belt. To release the locking mechanism, push the red button in the belt buckle and guide the belt back fully by hand.

⚠ WARNING

Incorrect handling of the safety belts increases the risk of severe or fatal injuries.

- Check the safety belts and associated components regularly to ensure they function correctly.
- Never attempt to repair safety belts. Have damaged safety belts replaced.
- Always keep the safety belts clean.
- Never damage the safety belts by trapping them or chafing them on sharp edges.
- Always keep the belt buckle and insertion guide for the belt buckle free of foreign objects and fluids.

Fastening and unfastening the safety belts

📖 Please read the introductory information and heed the Warnings and Notice ⇒ ⚠ [Introduction](#) .

Safety belts that are fastened correctly hold vehicle occupants in the correct position during braking maneuvers or in a collision, in order to provide the maximum protection ⇒ ⚠ .

Fastening the safety belt



Fig. 16 Inserting the buckle tongue into the safety belt buckle.

Always fasten the safety belts before driving.

1. Adjust the front seat and head restraint correctly ⇒ [Seating position](#) .
2. Have the rear seat backrest locked into place in an upright position ⇒ ⚠ .
3. Grab the belt and pull it evenly over the chest and pelvis. Do not twist the belt while doing this ⇒ ⚠ .
4. Insert the buckle tongue securely in the safety belt buckle for that seat [fig. 16](#) .
5. Pull on the safety belt to make sure the buckle tongue is latched correctly in the safety belt buckle.

Unfastening the safety belt



Fig. 17 Releasing the buckle tongue from the safety belt buckle.

Only unfasten the safety belt while the vehicle is stationary ⇒ ⚠.

1. Press the red button in the safety belt buckle *fig. 17*.

The buckle tongue will pop out.

2. Guide the belt back by hand so that the belt rolls up easily, the belt does not twist, and the trim panel is not damaged.

⚠ WARNING

Incorrect safety belt positioning or unfastening the safety belt while the vehicle is in motion can lead to serious or fatal injuries in the event of an accident or braking maneuver.

- Place the backrest in an upright position and position your safety belt correctly for your size to maximize the protective function of the safety belt.
- Never unfasten the safety belt while the vehicle is in motion.

Safety belt positioning

📖 Please read the introductory information and heed the Warnings and Notice ⇒ ⚠ Introduction.

Safety belts only offer the optimum protection during a collision and reduce the risk of serious injury or death if they are fastened and positioned correctly. The correct safety belt position also holds the vehicle occupant in place so that the airbags can provide their maximum protection if they deploy. Therefore, all vehicle occupants should always fasten their own safety belts and make sure they are positioned correctly *fig. 18*.

An incorrect seating position can cause severe or fatal injuries ⇒ *Seating position*.

Correct safety belt positioning

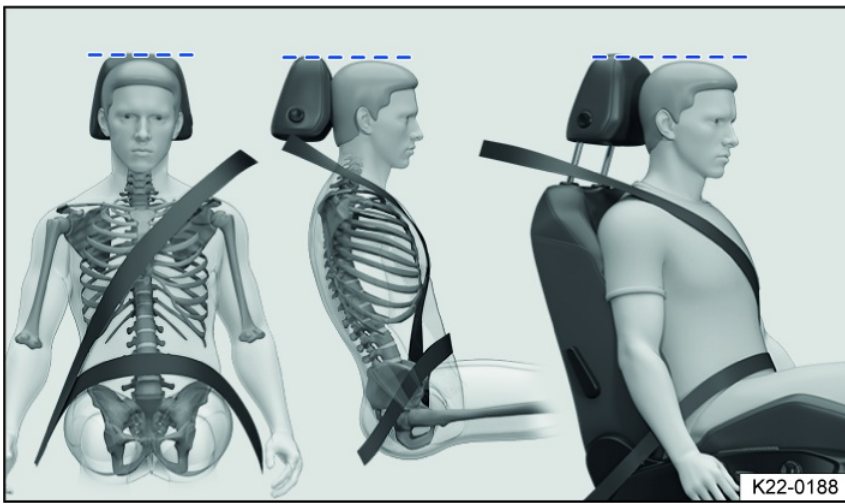

Fig. 18 Correct safety belt positioning and correct head restraint adjustment.

- The shoulder belt section of the safety belt must always be positioned over the center of the shoulder and never across the neck, above the arm, under the arm, or behind the back.
- The lap section of the safety belt must always lie across the lap and never over the stomach.
- The safety belt must always rest flat and securely on the body. Retighten the belt if necessary.

Correct safety belt positioning for pregnant women



Fig. 19 Correct safety belt positioning for pregnant women.

For pregnant women, the safety belt must rest evenly across the chest and as low and flat as possible on the lap, so that no pressure is applied to the lower abdomen. This should be done throughout the entire pregnancy *fig. 19*.

Adjusting the safety belt position to body size

The belt positioning can be adjusted with the following equipment:

- Belt height adjusters for the front seats → *Safety belt height adjuster*.
- Height-adjustable front seats → *Seating position*.

⚠ WARNING

Incorrect safety belt positioning can cause serious injuries in the event of an accident or during sudden braking or driving maneuvers.

- Ensure your safety belt is positioned correctly.
- Place the backrest in an upright position and position your safety belt correctly for your size to maximize the protective function of the safety belt.
- Place the shoulder portion of the safety belt over the center of your shoulder, and never under your arm or across your neck.
- Lay the safety belt flat and securely on the upper part of the body and pelvis. Retighten the belt if necessary.
- Ensure the lap section of the safety belt lies across your lap and never over your stomach.
- Throughout your pregnancy, ensure the safety belt rests evenly across your chest and as low and flat as possible on your lap. This will prevent pressure

being applied to your lower abdomen.

- Do not twist the safety belt while wearing it.
- Never hold the safety belt away from the body with your hand.
- Do not guide the safety belt over hard or breakable objects, such as eyeglasses, pens, or keys.
- Do not modify how the safety belt is routed using belt clips, retaining loops, or similar objects.

Information Persons who cannot achieve the optimum belt routing due to physical conditions should contact an authorized Volkswagen dealer or authorized Volkswagen Service Facility about possible special modifications that can be used to achieve the best possible protection with the safety belt and airbags. Volkswagen recommends contacting an authorized Volkswagen dealer or authorized Volkswagen Service Facility.

Safety belt height adjuster

Information Please read the introductory information and heed the Warnings and Notice ⇒ **Introduction**.



Fig. 20 Next to the front seats: safety belt height adjuster.

You can use the safety belt height adjuster to adjust the safety belt routing in the shoulder area according to your individual body size, so that the safety belt can be correctly fastened:

1. Push down and hold the safety belt height adjustment button in the direction of the arrows *fig. 20*.
2. Slide the safety belt height adjuster upward or downward until the safety belt lies over the center of the shoulder ⇒ *Safety belt positioning*.
3. Release the safety belt height adjustment button.
4. Pull hard on the safety belt to check that the safety belt height adjuster is engaged.

WARNING

Changing the safety belt height while driving may cause serious or fatal injuries.

- Never adjust the safety belt height while driving.

Automatic safety belt retractor, safety belt pretensioner, safety belt load limiter

Information Please read the introductory information and heed the Warnings and Notice ⇒ **Introduction**.

The vehicle seat belts are part of the vehicle safety concept ⇒ *Airbag system*. The vehicle safety concept has the following key functions:

Automatic safety belt retractor

Every safety belt is equipped with an automatic safety belt retractor on the shoulder belt section. If the safety belt is pulled slowly or while driving normally, the shoulder belt will be able to move freely. The automatic safety belt retractor blocks the safety belt from moving if the safety belt is pulled out quickly, for example during sudden braking maneuvers, when driving on hills, when driving around curves and when accelerating.

Safety belt pretensioners

The safety belts for the driver and front seat passenger are equipped with safety belt pretensioners.

Safety belt pretensioners are activated by sensors and tighten the safety belts in the event of severe front-on, side and rear collisions or if the vehicle rolls over. If the safety belt is loose, it retracts. This can reduce the forward movement of the vehicle occupants and movement of the vehicle occupants in the direction of the collision. The safety belt pretensioner works together with the airbag system. The safety belt pretensioner is only activated during a rollover accident if the Side

Curtain Protection® airbags are deployed.

Fine dust may appear if airbags deploy. This is completely normal and does not indicate a fire in the vehicle.

WARNING

The safety belt pretensioners only provide protection for one deployment. If the safety belt pretensioners deploy, the system must be replaced.

- Have deployed safety belt pretensioners and affected system components replaced immediately with new parts that are approved by Volkswagen for the vehicle.
- Only have suitably qualified professionals make repairs or modifications to a vehicle. Authorized Volkswagen dealers and authorized Volkswagen Service Facilities have the required tools, diagnostic devices, repair information, and qualified personnel. Volkswagen recommends contacting an authorized Volkswagen dealer or authorized Volkswagen Service Facility.
- Never install safety belt pretensioner components removed from scrap vehicles or from recycling.
- Never modify any components of the safety belt pretensioners.

Safety belt load limiter

Safety belt load limiters reduce the force placed on the body by the safety belts during a collision.

 **When disposing of the vehicle or of individual system components, all safety precautions must be observed. An authorized Volkswagen dealer or authorized Volkswagen Service Facility will be familiar with these provisions ⇒ *Safety belt pretensioner servicing and disposal*. Volkswagen recommends contacting an authorized Volkswagen dealer or authorized Volkswagen Service Facility.**

Safety belt pretensioner servicing and disposal

 **Please read the introductory information and heed the Warnings and Notice ⇒ *Introduction*.**

When working on safety belt pretensioners, as well as when removing and installing other vehicle components as part of repair work, the safety belts can become damaged without you noticing. This may cause the safety belt pretensioner to function incorrectly or prevent it from functioning in the event of an accident.

The instructions must be followed so that the effectiveness of the safety belt pretensioner is not impaired and removed components do not cause injuries and environmental pollution. An authorized Volkswagen dealer or authorized Volkswagen Service Facility will be familiar with these provisions. Volkswagen recommends contacting an authorized Volkswagen dealer or authorized Volkswagen Service Facility.

WARNING

Repairs that you perform yourself or that are performed incorrectly on the safety belts, automatic safety belt retractors, and safety belt pretensioners can increase the risk of severe or fatal injuries. The safety belt pretensioner may not deploy when it should, or it may deploy unexpectedly.

- Never perform repairs, adjustments, or removal and installation of components of the safety belt pretensioners or safety belts yourself. Only have these procedures performed by suitably qualified professionals ⇒ *Accessories, replacement parts, repairs, and modifications*. Volkswagen recommends contacting an authorized Volkswagen dealer or authorized Volkswagen Service Facility.
- Safety belts, safety belt pretensioners and automatic safety belt retractors cannot be repaired. These components must be replaced.

 Some parts of the vehicle, such as the airbag module and safety belt pretensioners, may contain perchlorate. Special handling may be necessary. For further information, visit <https://dtsc.ca.gov/perchlorate>.

Airbag system

Introduction

The vehicle is equipped with a front airbag for the driver and one for the front passenger. The front airbags can offer additional protection for the chest and head of the driver and front passenger as long as the seat, the safety belt, the head restraint, and the steering wheel are adjusted and used correctly. Airbags are only designed to offer supplementary protection. Airbags are not a replacement for safety belts. Safety belts must always be worn, even if the front seats are fitted with front airbags.

WARNING

Never rely only on the airbag system for protection.

- Even when an airbag deploys, it only offers supplementary protection.
- The airbag system provides optimum protection when the safety belt is worn correctly and it reduces the risk of injury ⇒ *Safety belts*.
- Before every trip, everyone in the vehicle must seat themselves correctly, fasten the safety belt that belongs to the seat they are using, and keep it fastened while the vehicle is in motion. This applies to all passengers and at all times, including during city driving.

WARNING

Sitting too close to the steering wheel or the instrument panel reduces the effectiveness of the airbags and increases the risk of injury in the event of a collision.

- Adjust the driver seat so that there is a distance of at least 10 inches (25 cm) between your chest and the center of the steering wheel.
- Adjust the front passenger seat so that there is the greatest possible distance between the front passenger and the instrument panel.
- If body characteristics mean that this is not possible, see an authorized Volkswagen dealer or authorized Volkswagen Service Facility to have special modifications made. Volkswagen recommends contacting an authorized Volkswagen dealer or authorized Volkswagen Service Facility.
- If you have not fastened your safety belt correctly, if you lean forwards, sit sideways or are in any way seated outside the intended sitting position, the risk of you being injured is far higher.
- Make sure that your safety belt is fastened correctly to reduce the risk of injury if an airbag deploys.
- When using a rear-facing child restraint on the front passenger's seat, the risk of life-threatening or fatal injuries in the event of a collision increases for the child. Never use rear-facing child restraints on the front passenger's seat.
- Make sure that children under 12 years of age always sit on a rear seat. Children that are not correctly strapped in can suffer serious or even fatal injuries if the airbag deploys.
- Secure children in the vehicle with a child restraint that is appropriate for their weight and height and with the safety belt used correctly.
- Adjust the front seats correctly.
- Never drive with the backrest angled too far back or forward.
- Position the seat backrest in an upright position, so that your back rests completely on the seat backrest.
- Always keep feet in the footwell while driving. For example, never rest feet on the seat or on the instrument panel and never hold feet out of the window. Otherwise, if the airbag and the safety belt deploy, they could increase the risk of injury in the event of an accident instead of providing protection.

WARNING

The risk of injury if the airbag deploys increases if there are objects located between vehicle occupants and the airbag deployment zone. These objects could change the deployment zone of the airbag or could strike the vehicle occupants.

- Never hold objects in your hands or on your lap while driving.
- Never transport objects on the front passenger's seat. During sudden braking or driving maneuvers, the objects could move into the airbag deployment zone and then be thrown through the vehicle interior if the airbag deploys.
- There should be no people, animals, or objects between the occupants of the front seats or outer rear seats and the airbag deployment zone. Make sure that child and adult passengers also follow these instructions.

WARNING

The airbag system only provides protection for one deployment. If the airbags deploy, the system must be replaced.

- Have deployed airbags and affected system components replaced immediately with new parts approved by Volkswagen for the vehicle.
- Only have suitably qualified professionals make repairs or modifications to a vehicle. Suitably qualified professionals have the required tools, diagnostic devices, repair information, and qualified personnel. Volkswagen recommends contacting an authorized Volkswagen dealer or authorized Volkswagen Service Facility.
- Never install airbag components removed from scrap vehicles or from recycling.
- Never modify any components of the airbag system.

WARNING

Fine dust and water vapor can develop when the airbags deploy. This is normal and does not indicate a fire in the vehicle.



- The fine dust can irritate the skin and mucous membranes in the eyes and can cause breathing problems, particularly for individuals who have asthma or other respiratory conditions. To reduce the risk of breathing problems, exit the vehicle or open the windows or doors for fresh air.
- If you come into contact with the dust, wash your hands and face with mild soap and water before eating anything.
- Do not allow the dust to come into contact with your eyes or any open wounds.
- Flush your eyes with water if dust enters them.

WARNING

Cleaners that contain solvents can make the surface of the airbag module porous. Plastic pieces that come loose could cause serious injuries in the event of a collision with airbag deployment.

- Never treat the instrument panel and the surface of the airbag modules with cleaners that contain solvents.

Advanced Airbag System



 Please read the introductory information and heed the Warnings and Notice ⇒  Introduction.

Read and follow the introductory information and safety precautions ⇒ Safety notes on using child restraints.

An active passenger's front airbag presents serious dangers for a child ⇒ . For this reason, all children under the age of twelve must be secured in the rear seats while the vehicle is in motion.

The Advanced Airbag System, together with the side and Side Curtain Protection® airbags, is checked every time the ignition is switched on. The yellow airbag indicator light  comes on briefly and turns off after several seconds.

Features of the Advanced Airbag System:

- Front passenger's front airbag in the instrument panel
- Yellow indicator light  in the instrument cluster display.
- Yellow PASSENGER AIR BAG indicator light **OFF** .
- Yellow PASSENGER AIR BAG indicator light **ON** .

If the status of the  indicator light is one of the following, the Advanced Airbag System must be checked by an authorized Volkswagen dealer or authorized Volkswagen Service Facility:

- The indicator light does not come on for several seconds when the ignition is switched on.
- The indicator light stays on after the ignition is switched on.
- The indicator light comes on or flashes again after it is turned off.
- The indicator light comes on while driving.

Advanced Airbag System, small children, child restraints and children on the front passenger seat

The Advanced Airbag System in your vehicle has been certified and complies with the regulations of the United States Federal Motor Vehicle Safety Standard (FMVSS) 208 and the Canada Motor Vehicle Safety Standard (CMVSS) 208 at the time of vehicle manufacture. In accordance with the requirements, the system on the passenger's side has been designed to "inhibit" deployment for small children of up to 12 months of age and "low-risk deployment" for children of between three and six years of age.

The airbag on the passenger's side is a potential danger for children when it is deployed. The front passenger seat is not the safest seat for a child in a forward-facing child restraint and is a very dangerous seat for a child or small child in a backward-facing child restraint.

The Advanced Airbag System has a capacitive detection system in the seat cushion of the front passenger seat which detects whether a baby, small child or child is in a child restraint on the front passenger seat.

The capacitive detection system measures the electrical capacity of a child, the child restraint and a child's blanket on the front passenger seat.

The electrical capacity of a child restraint depends on the child restraint type. Together with the average capacity values of small children and one-year-old children the capacity values of all child restraints specified in accordance with FMVSS 213 and CMVSS 213 are stored in the Advanced Airbag System control module. These are compared with the values detected. Only use child restraints that are specified according to these standards and have been approved by the child restraint manufacturer for use with airbag systems. The U.S. National Highway Traffic Safety Administration (NHTSA) has published a list of certified child restraint models for use with the Advanced Airbag System in accordance with FMVSS 208.

Only install child restraints on the front passenger seat under exceptional circumstances. Carefully read all of the information about child restraints and the Advanced Airbag System beforehand and follow all instructions and warnings. Make sure that the system has correctly detected the child restraint on the front passenger seat and the front passenger's front air bag has been switched off. The yellow **OFF**  PASSENGER AIR BAG indicator light will come on.

DANGER

The front passenger seat of a vehicle is a potential danger to children (even for advanced airbags). In the event that front passenger seat air bags are deployed, children who are completely unsecured in an unsecured child restraint or in a rear-facing child restraint on the front passenger seat will suffer serious or fatal injuries.

- Even if your vehicle is equipped with an Advanced Airbag System, make sure that children (particularly children younger than 12 years of age) are always transported in such a way that they are secured to the rear seats according to their age and size.

Indicator light for front passenger's front airbag

 Please read the introductory information and heed the Warnings and Notice ⇒  Introduction.

PASSENGER AIR BAG



Fig. 21 In the roof console: indicator light (general example) for the switched off front passenger's front airbag.



PASSENGER AIR BAG



Fig. 22 In the roof console: Indicator light (general example) for the activated front passenger's front airbag.



The yellow PASSENGER AIR BAG indicator light **OFF**  fig. 21 comes on as soon as the Advanced Airbag System has deactivated the front passenger airbag.

The yellow PASSENGER AIR BAG indicator light **ON**  fig. 22 comes on as soon as the Advanced Airbag System has activated the front passenger airbag.

If the yellow PASSENGER AIR BAG indicator light **OFF**  malfunctions, the yellow indicator light  appears in the instrument cluster to indicate a malfunction. A faulty indicator light does not affect the function of the front passenger's front airbag, but the yellow PASSENGER AIR BAG indicator light **OFF**  can no longer be used to display the status of the front passenger's front airbag. Get professional assistance immediately to have the system checked. Volkswagen recommends contacting an authorized Volkswagen dealer or authorized Volkswagen Service Facility.

The yellow **OFF**  PASSENGER AIR BAG indicator light blinks for around five seconds in the following situations:

- The capacitive passenger detection system detects that the front passenger seat is not occupied.
- The capacitive passenger detection system detects a child restraint according to FMVSS 208 or CMVSS 208 ⇒ *Airbag system*.

The yellow **ON**  PASSENGER AIR BAG indicator light blinks for around five seconds when the capacitive passenger detection system has detected an adult occupying the seat. The yellow PASSENGER AIR BAG indicator light **ON**  then lights up for about 60 seconds and goes out.

Ensure that the status of the airbag (on or off) is shown correctly by the indicator light according to the load on the seat.

The yellow PASSENGER AIR BAG indicator light **OFF**  must come on when the ignition is switched on and an infant carrier or child restraint is installed on the front passenger seat and the measured capacity is less than or equal to the capacity of an average one-year old child in a child restraint system as per FMVSS 208

If the front passenger seat is not occupied, the front passenger's front airbag is also deactivated and the indicator light remains on.

Never install a rear-facing child restraint on the front passenger seat. The safest place for a child restraint is on the rear seat.

Under these conditions, the yellow PASSENGER AIR BAG indicator light **OFF**  must come on permanently whenever the ignition is on. If this is not the case, stop the vehicle as soon as it is safe to do so and follow these instructions:

- Switch the ignition off for at least 4 seconds and then on again.

- Remove the child restraint from the front passenger seat and install it again according to the manufacturer's instructions. When doing so, ensure that the child restraint is installed correctly.
- Ensure that the safety belt has been guided around the child restraint correctly and that it is secure.
- Ensure that there are no electronic devices on the front passenger seat.
- Ensure that the safety belt and belt buckle are working correctly and not blocked.
- Ensure that no seat heating or similar systems have been retrofitted.
- Ensure that there are no damp objects on the front passenger seat.



If the yellow PASSENGER AIR BAG indicator light  still does not come on, remove the child restraint immediately and install it on the rear seat. Visit an authorized Volkswagen dealer or authorized Volkswagen Service Facility as soon as possible to have the airbag system checked. Volkswagen recommends contacting an authorized Volkswagen dealer or authorized Volkswagen Service Facility.



The yellow PASSENGER AIR BAG indicator light  must not come on if the front passenger seat is occupied by an adult. However, if this is the case, stop the vehicle as soon as it is safe to do so and ensure the following:

- Ensure that the passenger is sitting in the middle of the seat and that the backrest is upright.
- Ensure that the belt is correctly positioned and tight.
- Ensure that there are no other objects on the seat cushion, such as blankets or booster seats, that could affect the system's ability to detect a passenger.

If the yellow PASSENGER AIR BAG indicator light  is still permanently on, the passenger must move to the rear seat. Visit an authorized Volkswagen dealer or authorized Volkswagen Service Facility as soon as possible to have the airbag system checked. Volkswagen recommends contacting an authorized Volkswagen dealer or authorized Volkswagen Service Facility.

If the status of the Advanced Airbag System changes when you are driving, the relevant yellow indicator light blinks for around five seconds. Stop the vehicle as soon as it is safe to do so and follow the instructions specified here.

If the system recognizes an unoccupied front passenger seat or child restraint according to FMVSS 208 or CMVSS 208, the front passenger airbag remains deactivated and the yellow PASSENGER AIR BAG indicator light  comes on permanently. If the front passenger seat is unoccupied and the passenger's safety belt is fastened, the yellow PASSENGER AIR BAG indicator light  also comes on permanently.

If the front passenger seat is occupied by an adult, the front passenger airbag is activated and the yellow PASSENGER AIR BAG indicator light  blinks for around five seconds when the capacitive passenger detection system has detected an adult occupying the seat. The yellow PASSENGER AIR BAG indicator light  then lights up for about 60 seconds and goes out.

Troubleshooting

 Please read the introductory information and heed the Warnings and Notice →  **Introduction.**

Airbag system or safety belt pretensioners malfunction

The yellow indicator light stays on. There may also be a message in the instrument cluster display.

A malfunction has been detected in at least one of the airbags or safety belt pretensioners.

1. Visit an authorized Volkswagen dealer or authorized Volkswagen Service Facility and have the airbag system and safety belt pretensioners checked. Volkswagen recommends contacting an authorized Volkswagen dealer or authorized Volkswagen Service Facility.

Airbag system or safety belt pretensioners deactivated with diagnostic device

After the ignition is switched on, the yellow indicator light turns on for about four seconds and then blinks for about twelve seconds. There may also be a message in the instrument cluster display.

At least one airbag or safety belt pretensioner has been switched off by a diagnostic device.

1. Have a suitably qualified professional check whether the airbag system or safety belt pretensioners need to remain switched off. Volkswagen recommends contacting an authorized Volkswagen dealer or authorized Volkswagen Service Facility.

Front passenger's front airbag switched off

The yellow indicator light stays on.

The front passenger's front airbag is switched off.

1. Check whether the front passenger's front airbag has to be switched off.
2. If the front passenger's front airbag is incorrectly switched off, there may be a malfunction in the airbag system. Contact an authorized Volkswagen dealer or authorized Volkswagen Service Facility. Volkswagen recommends contacting an authorized Volkswagen dealer or authorized Volkswagen Service Facility.



Front passenger's front airbag enabled

The yellow indicator light blinks for about five seconds when the capacitive passenger detection system has detected an adult occupying the seat. The yellow indicator light then lights up for about 60 seconds and goes out.

The front passenger's front airbag is switched on.

1. Ensure that the correct status of the airbag (on or off) is shown by the indicator light according to the load on the seat.

Airbag description and function

 Please read the introductory information and heed the Warnings and Notice ⇒  Introduction.

The airbag can protect vehicle occupants in a collision by reducing the movement of vehicle occupants in the direction of the impact during frontal and side collisions.

The airbag is filled by a gas generator when it deploys. When this occurs, the airbag covers open and the airbags unfold with great force into their deployment zones within milliseconds. When vehicle occupants who are wearing safety belts sink into the airbags, the gas contained in the airbags is released in order to cushion the individuals and slow their movement. This can reduce the risk of serious and fatal injuries. The airbag cannot always prevent other injuries, such as swelling, bruises, burns, and abrasions. Heat from friction can develop when the airbag deploys.

Airbags do not provide any protection for arms and the lower part of the body.

The most important factors for triggering airbag deployment are the type of collision, the angle of impact, the vehicle speed, and the characteristics of the object with which the vehicle is colliding. Therefore, the airbags will not deploy in all situations where there is visible vehicle damage.





The deployment of the airbag system depends on the vehicle deceleration rate resulting from the impact, which is detected by an electronic control module. If the deceleration rate is below the minimum value programmed into the control module, then the airbags will not be deployed even though there may be significant vehicle damage. The extent of vehicle damage, the repair costs, or even the absence of vehicle damage in a collision are not indicators of whether the airbag should have deployed or not. Because situations can vary greatly among different collisions, it is not possible to define a range of vehicle speeds and reference values. Therefore, it is not possible to cover every conceivable type of impact and impact angle that could trigger airbag deployment. Among other things, important factors for airbag deployment include the characteristics of the object with which the vehicle collides (hard or soft), the angle of impact, and the vehicle speed.

Airbags are only a supplement to the three-point safety belts in some collisions when the deceleration of the vehicle is great enough to trigger airbag deployment. Airbags can only deploy once, and only under certain conditions. The safety belts are always there to provide protection in situations where the airbags do not deploy or if they have already deployed — for example, this may be the case if the vehicle collides with another vehicle or is hit by another vehicle after the initial impact.

The airbag system is part of the entire passive vehicle safety concept. The airbag system can only provide the best possible protection when it works in conjunction with safety belts that are fastened correctly and a correct seating position  ⇒ Seating position, ⇒ Safety belts.

Components of the vehicle safety concept

The vehicle safety concept is comprised of the following safety features in the vehicle that reduces the risk of serious and fatal injuries. Depending on vehicle equipment, some equipment may not be installed in the vehicle or may not be available in some countries.

- Optimized safety belts in all seating positions.
- Safety belt pretensioners for the driver and front passenger.
- Belt tension limiter for the driver and front passenger and for the outer rear seats.
- Belt height adjusters for the front seats.
- Red warning light .
- Front airbags for the driver and front passenger.
- Advanced Airbag System for the driver and front passenger.
- Capacitive passenger detection system for the front passenger's airbag.
- Side airbags for the driver and front passenger.
- Side Curtain Protection® for outer seats.
- Yellow airbag indicator light .
- Yellow PASSENGER AIR BAG indicator light **OFF**  in the roof console.
- Yellow PASSENGER AIR BAG indicator light **ON**  in the roof console.
- Control modules and sensors.
- Safety-optimized and height-adjustable head restraints.
- Adjustable steering column.
- Anchorage points for child restraints on the rear seats.
- Anchorage points for the top tether strap for child restraints.

How the components of the Advanced Airbag System work together:

On the passenger's side, regardless of whether the safety belt is being used or not, the front passenger's front airbag is switched off if the electrical capacity measured on the front passenger seat by the capacitive passenger detection system is smaller than the value saved in the control module. The front passenger's front airbag is also switched off if the measured capacity corresponds to the value for an infant of around one year old in a child restraint certified in accordance with the Federal Motor Vehicle Safety Standard 208.



The indicator light for the front passenger's front airbag lights up continuously to tell you that the Advanced Airbag System on the front passenger side has been

deactivated.



Situations where front airbags, side airbags or Side Curtain Protection® airbags do not deploy:

- If the ignition is switched off in a collision.
- Deceleration measured at the vehicle front end during the collision is too low for the control module.
- In minor side collisions.
- The dynamics measured by the control module during a rollover are too low.
- In rear collisions.
- If the collision speed is lower than the required reference value in the control module.

Components of the Advanced Airbag System

 Please read the introductory information and heed the Warnings and Notice ⇒  Introduction.

The following components are essential parts of the Advanced Airbag System:

- Capacitive passenger detection system in the front passenger seat.
- Optimized safety belts with safety belt pretensioners and safety belt load limiters.
- Front airbags for the driver and front passenger.
- Airbag indicator light .
- PASSENGER AIR BAG OFF  indicator light
- PASSENGER AIR BAG ON  indicator light
- Control modules and sensors.

WARNING

Airbags and safety belt pretensioners that do not function properly can cause serious or fatal injuries in the event of an accident.

- If the airbag indicator light turns on, have the system inspected by an authorized Volkswagen dealer or authorized Volkswagen Service Facility as soon as possible. Volkswagen recommends contacting an authorized Volkswagen dealer or authorized Volkswagen Service Facility.
- Only use original Volkswagen replacement parts and have the installation performed by authorized specialists only.
- Never use used or recycled airbags or parts in the Advanced Airbag System. Only use new parts.

WARNING

Damage to the front passenger seat may affect the function of the Advanced Airbag System and cause severe or fatal injuries.

- Have damaged components in the front passenger seat and the capacitive detection system replaced by authorized specialists as soon as possible.
- Never remove the front passenger seat or components of the front passenger seat, such as seat surfaces, wires, lines or seat covers.
- Never damage the seat covers or the seat surface of the front passenger seat.
- Never use protective covers or seat surfaces on the front passenger seat as these affect the capacitive detection system.
- Never transport electronic or electrical objects on or under the front passenger seat as these affect the capacitive detection system.
- Never use protective covers, cushions or similar items on the front passenger seat as these affect the capacitive detection system.
- Never install seat heating on the front passenger seat.
- Never replace the seat cover on the front passenger seat.

WARNING

If the front passenger seat becomes wet or damp, this can cause the Advanced Airbag System to malfunction.

- Allow the seat to dry as soon as possible and check it for damage.

Front airbags

 Please read the introductory information and heed the Warnings and Notice ⇒  Introduction.



K21-0436

Fig. 23 Installation location and deployment zone of the driver's front airbag.

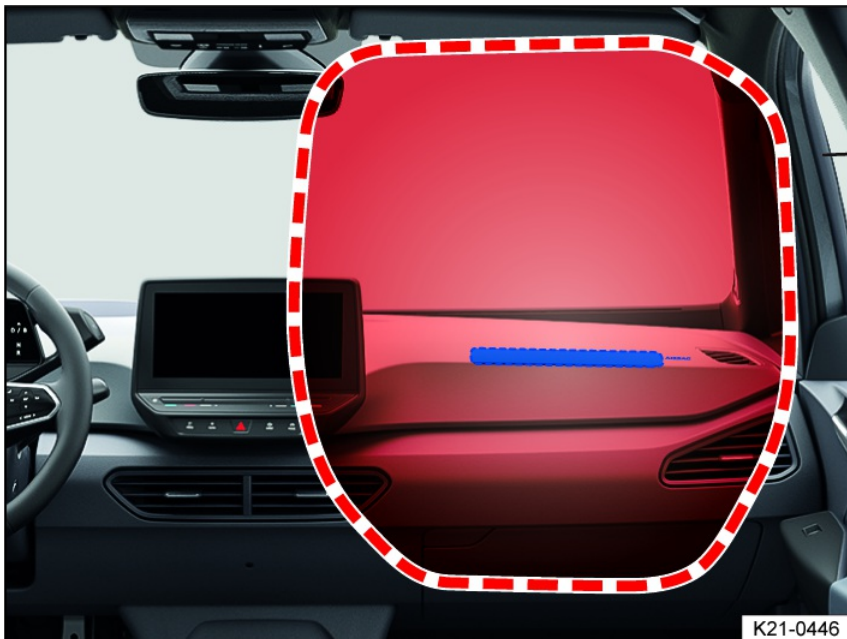

K21-0446

Fig. 24 Installation location and deployment zone of the front passenger's front airbag.

As a supplement to the safety belts, the front airbag system offers additional protection for the head and chest regions of the driver and front passenger during front collisions with higher impact severity. In certain head-on collisions, the Side Curtain Protection® airbags will also deploy on both sides.

Always maintain as much distance as possible to the front airbag ⇒ *Seating position*. This allows the front airbags to expand completely during collisions and thus provide maximum protection.

The front airbag for the driver is located in the steering wheel *fig. 23* and the front airbag for the front passenger is located in the instrument panel *fig. 24*. The airbag installation locations are marked with the lettering "AIRBAG".

The area outlined in red defines where the front airbags will deploy (deployment zone). Therefore, never place or attach objects in these areas ⇒ ⚠. The attachments mounted at the factory will not be affected by the deployed driver's and front passenger's front airbag.

The front airbags do not deploy in the following situations:

- In case of crashes when the ignition is switched off.
- In side-on collisions.
- In case of a rear-end collision.
- If the vehicle rolls over.
- If the impact speed is too low.

The front passenger's front airbags do not deploy in the following situations:

- If the front passenger seat is not occupied.
- If the passenger seat recognition system recognizes that the front passenger seat is unoccupied and the PASSENGER AIR BAG OFF  indicator light comes on.

on.

⚠ DANGER

An airbag deploys within a few milliseconds and at a very high speed.

- Always keep the deployment zones of the front airbags clear.
- Never attach objects to the covers or in the deployment zone of the airbag module, such as cup holders or phone holders.
- There should be no people, animals, or objects between the occupants of the front seats and the airbag deployment zone. Make sure that children and passengers also follow this guideline.
- Do not attach any objects, such as mobile navigation systems, to the windshield above the front airbag on the passenger's side.
- Do not tape over or cover the steering wheel airbag module or the surface of the instrument panel in the deployment zone of the front passenger's front airbag, or modify them in any other way.

⚠ WARNING

The front airbags expand in front of the steering wheel [fig. 23](#) and the instrument panel [fig. 24](#).

- Always hold the steering wheel with both hands on the sides of the outer edge, in the nine o'clock and three o'clock position.
- Adjust the driver seat so that there is a distance of at least 10 inches (25 cm) between your chest and the center of the steering wheel. If body characteristics mean that this is not possible, you must contact an authorized Volkswagen dealer or authorized Volkswagen Service Facility. Volkswagen recommends contacting an authorized Volkswagen dealer or authorized Volkswagen Service Facility.
- Adjust the front passenger seat so that there is the greatest possible distance between the front passenger and the instrument panel.

Side airbags

 Please read the introductory information and heed the Warnings and Notice  [Introduction](#).

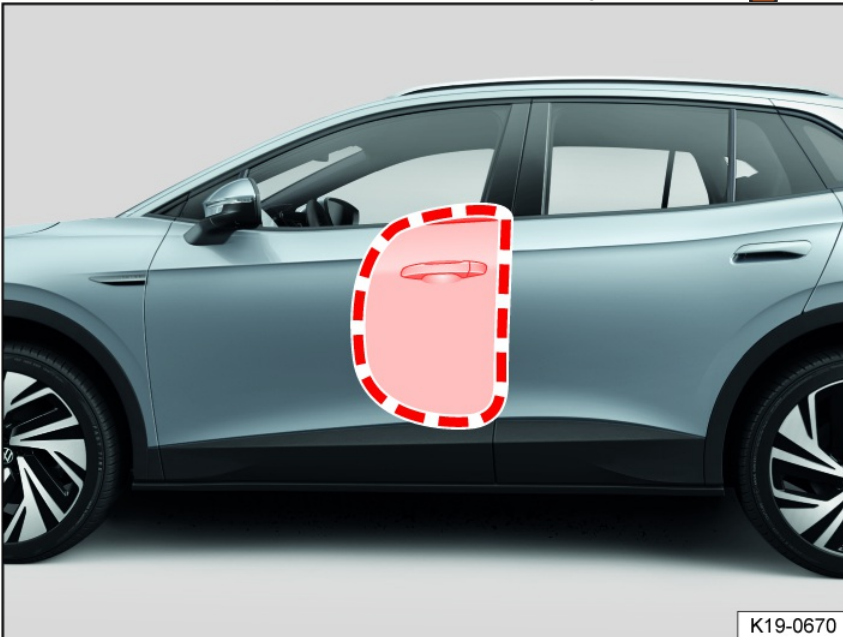

Fig. 25 In the vehicle interior on the left-hand side: Side airbag deployment zone.

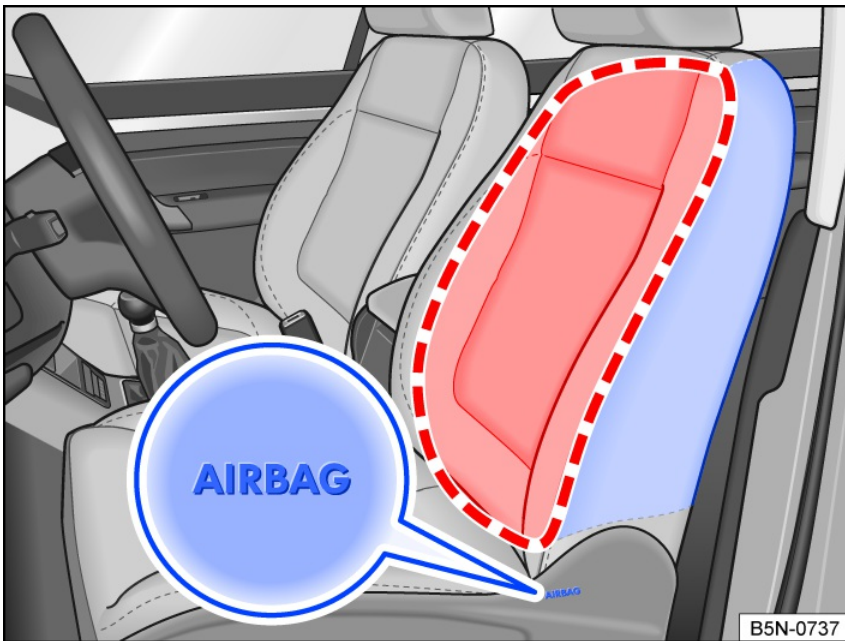

Fig. 26 On the side of the front seat: Side airbag installation location and deployment zone

The installation locations of the side airbags are marked with the word "AIRBAG".

The area outlined in red defines where the side airbags will deploy (deployment zones) *fig. 26, fig. 25*. Therefore, never place or attach objects in these areas ⇒ ⚠️

In the event of a side impact collision, the side airbags reduce the risk of injury to the vehicle occupants on the side of impact. The Side Curtain Protection® airbags will deploy on both sides.

⚠️ WARNING

An airbag deploys within a few milliseconds and at a very high speed.

- Always keep the deployment zones of side airbags clear.
- Only hang lightweight clothing from the garment hooks in the vehicle. Never store heavy or sharp-edged objects in pockets.
- Do not attach any accessories to the doors.
- Only use seat covers or protective covers that are specifically approved for use in your vehicle. Otherwise, the side airbag may not expand when deployed.

⚠️ WARNING

Incorrect handling and use of the driver's and front passenger's seat can inhibit the side airbags from functioning correctly and cause serious injuries.

- Never remove the front seats from the vehicle or modify parts of them.
- If too much force is applied to the seat backrest bolsters, the side airbags may not deploy correctly, deploy unexpectedly, or not deploy at all.
- Have any damage to the seat covers or the seam in the side airbag module areas repaired immediately by suitably qualified professionals. Volkswagen recommends contacting an authorized Volkswagen dealer or authorized Volkswagen Service Facility.

Side Curtain Protection

📖 Please read the introductory information and heed the Warnings and Notice ⇒ ⚠️ *Introduction*.

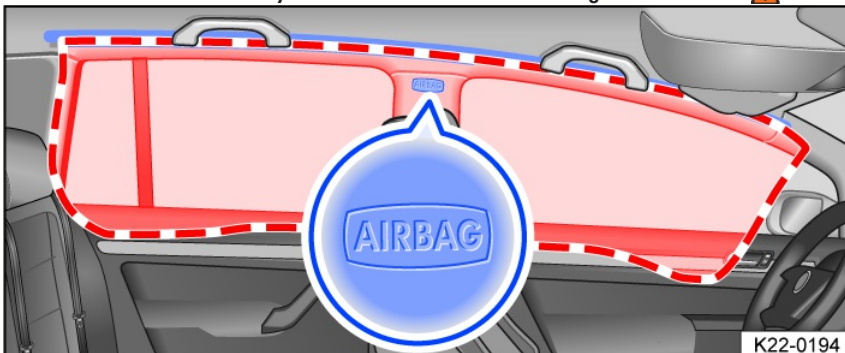



Fig. 27 On the left side of the vehicle: installation location and deployment zone of the Side Curtain Protection®.

Side Curtain Protection® airbags are located on the driver's and passenger's side in the vehicle interior above the doors *fig. 27*.

The installation locations of the Side Curtain Protection® are marked with the word “AIRBAG”.

The area outlined in red defines where the Side Curtain Protection® airbags will deploy (deployment zone) *fig. 27*. Therefore, never place or attach objects in this area ⇒ .

In side collisions and certain head-on collisions, the Side Curtain Protection® airbags will also deploy on both sides.

Side Curtain Protection® airbags offer the “ejection mitigation” function, which protects the vehicle occupants and body parts from being completely or partially ejected from the vehicle in the event of a side impact collision or if the vehicle rolls over.

The Side Curtain Protection® airbags reduce the risk of injury to vehicle occupants in the front and outer rear seats during a side collision and certain head-on collisions.

Side Curtain Protection® airbags are composed of the following components:

- Control module and sensors.
- Side Curtain Protection airbags.
- Airbag indicator light ⇒ *Indicator light for front passenger's front airbag*.

The Side Curtain Protection® airbags do not deploy in the following situations:

- In case of crashes when the ignition is switched off.
- In certain side collisions with a low force that does not trigger the sensor.
- In case of a rear-end collision.
- In the case of certain head-on collisions.
- In certain rollovers with a low momentum that do not trigger the sensor.
- If the impact speed is too low.

WARNING

An airbag deploys within a few milliseconds and at a very high speed.

- Always keep the Side Curtain Protection® airbag deployment zones clear.
- Never attach objects to the cover or within the Side Curtain Protection® airbag deployment zone.
- There should be no people, animals, or objects between the occupants of the front seats or outer rear seats and the airbag deployment zone. Make sure that children and passengers also follow this guideline.
- Only hang lightweight clothing from the garment hooks in the vehicle. Never store heavy or sharp-edged objects in pockets.
- Do not attach any accessories to the doors.
- Do not attach any sunshades to the side windows that are not specifically approved for use in the vehicle.
- Only pivot sunshades toward the side windows if no objects such as pens or garage door openers are attached to the visor.

Transporting children safely

Introduction

The physical principles in the event of an accident also apply to children. However, due to their size and other factors, they face a greater risk of injury.

Children and babies must therefore always be transported in child restraint systems that are designed for their age, size, weight and body structure. In the USA and Canada, the use of tested and certified child restraint systems is required by law.

In the case of head-on collisions at speeds of between 30 and 55 km/h (approx. 20–35 mph), a small child weighing 6 kg (13 lbs) will be subjected to forces of more than 20 times their body weight. This means that the child's effective weight will suddenly increase to up to 120 kg (260 lbs). Under such conditions, only a child restraint used in accordance with regulations can reduce the risk of injury. However, a child restraint which is not used in accordance with regulations may further increase the risk of injury!

All children (particularly children under 12 years of age) should always be transported on the rear seats in appropriate child restraint systems. However, if you must use a child restraint on the front passenger seat in exceptional circumstances, always follow all the information and warnings available at ⇒  *Introduction*.

You can find more information on this subject at:

National Highway Traffic Safety Administration (NHTSA) (USA):

<http://www.safercar.gov>

Transport Canada Information Centre (Kanada):

<http://www.tc.gc.ca>

Read and follow the instructions from the child seat manufacturer to ensure that the seat is appropriate for your child. Also be sure to read and follow all the information and warnings on child restraint systems in this manual!

WARNING

In the event of an accident, people sitting on the front passenger seat (particularly children and small children) may suffer severe or fatal injuries if there is not sufficient distance between them and the airbag, if it is deployed (even with the Advanced Airbag System)!

- The safest place for children is on the rear seats.
- A suitable child restraint that is installed on the rear seat in accordance with regulations provides the highest level of protection for children and small children in most accidents.
- Even though the Advanced Airbag System is designed to detect child restraint systems on the front passenger seat and to switch off the front passenger's front airbag, it is not possible to guarantee that the system will perform correctly under all circumstances and over the vehicle's service life.
- In compliance with the "low risk" option for children of 3–6 years of age according to the U.S. Federal Standard, the Advanced Airbag System may be deployed if the electrical capacity of a typical one-year-old child combined with a child restraint system on the front passenger seat is exceeded and the criteria for deployment of the Advanced Airbag System are met.

⚠ WARNING

Accident statistics have shown that the rear seats offer greater safety than the front seats for children in general.

- Always transport children under 12 years of age on the rear seats.
- A child who is not secured or is not secured properly can be injured through sliding around in the vehicle interior or through being ejected from the vehicle during a sudden maneuver or collision. Secure children in the vehicle with a child restraint that is appropriate for their weight and height and with the safety belt used correctly ⇒ [Transporting children safely](#).
- A child who is not secured or not properly secured is exposed to an increased risk of injury or death through collision with an airbag. Make sure that children are not within the deployment zone of the airbag.
- A child restraint system corresponding to body weight and body size that is installed and used on the rear seats offers maximum protection for infants and small children in most accident situations.

Child restraints – overview

📖 Please read the introductory information and heed the Warnings and Notice ⇒ [Introduction](#).

All children (particularly small children and infants) must be transported in child restraints suitable for them. These child restraints must always be installed correctly. The information in the following table will help you to find the suitable child restraint for your child.

Child restraint type	Use
Rear-facing child restraint	Birth–12 months old: A child of up to 12 months of age must always be transported in a rear-facing child restraint. There are different types of these: <ul style="list-style-type: none"> – Rear-facing child restraints for infants only. – Convertible and multi-purpose child restraints with greater weight and size restrictions for transporting your child in the rear-facing position for longer periods of time.
Rear-facing child restraint before transitioning to the forward-facing child restraint	1 – 3 years old: Transport your child in a rear-facing child restraint for as long as possible until they have reached the weight and size restrictions. After your child has reached the weight and size restrictions, you can transport them in a forward-facing child restraint with the appropriate safety belts.
Forward facing child restraints	4 – 7 years old: Transport your child in a forward-facing child restraint for as long as possible until they have reached the weight and size restrictions. After your child has reached the weight and size restrictions, you can transport them in a booster seat but only on the rear seats.
Booster seat	7 – 12 years old: Transport your child using a booster seat until they have grown enough to sit on the seats with a safety belt without a booster seat. The safety belt must be routed correctly ⇒ Safety belt positioning . You should continue to transport your child on the rear seats.

Child restraints can be fastened either with a three-point safety belt or with an ISOFIX/lower LATCH fastening system. Many child restraints also require the use of top tether systems. Depending on countries and federal states, the use of Top Tether may even be required by law.

How to determine whether a child restraint is installed correctly

- The child restraint lies flush against the seat cushion and the backrest unless the child restraint manufacturer allows a gap between the seat and child restraint.
- The overhang of the child restraint on the seat cushion is not longer than 20% of the child restraint. Always follow the instructions for the permitted child restraint overhangs.
- You should always position the child restraint centrally on the seat.
- The clearance of the child restraint forward and sideways is no greater than approximately 2.5 cm (1 inch).
- The child restraint must not rest on the belt buckles of the seats. These could be damaged as a result.
- When installing multiple child restraints, they must not block each other and must be free-standing and remain accessible.

- The child restraint has been secured correctly using the three-point safety belt or ISOFIX/lower LATCH anchorage point. The top tether system of the child restraint has also been used correctly as specified by the manufacturer.

DANGER

Not using the child restraint, using it incorrectly or using the wrong child restraint increases the risk of severe or fatal injuries in the event of a collision or an accident.

- Children sitting on the front seats may suffer severe or fatal injuries in the event of airbag deployment (even if advanced airbags are used).
- Children in a rear-facing child restraint on the front passenger seat may suffer severe or fatal injuries in the event of airbag deployment.
- Always install child restraints on the rear seats.
- If, in exceptional circumstances, you nevertheless install a child restraint on the front passenger seat and the yellow **OFF**  PASSENGER AIR BAG indicator light does not come on and stay on, remove the seat immediately and have the airbag system checked by an authorized Volkswagen dealer or authorized Volkswagen Service Facility. Volkswagen recommends contacting an authorized Volkswagen dealer or authorized Volkswagen Service Facility.

WARNING

If the airbag is deployed, a child restraint on the front passenger seat may collide with the airbag and the child in the child restraint may suffer severe or even fatal injuries (even if advanced airbags are used). If, in exceptional circumstances, you nevertheless install a child restraint on the front passenger seat, observe the following points:

- Forward-facing child restraints may be situated in the deployment zone of a front passenger's front airbag and may result in severe or fatal injuries if the airbag is deployed. Always ensure that the child restraint in use has been approved by the manufacturer for use on the front passenger seat.
- Read and always follow the child seat manufacturer's instructions.
- Never install a child restraint without a top tether safety belt if this is required by the manufacturer or by law.
- Never position a forward-facing child restraint directly on the instrument panel.
- Adjust the seat belt adjuster so that the seat can be installed correctly.
- Position the front passenger seat as high as possible and move it as far back as possible in order to obtain the largest possible distance to the instrument panel.
- Make sure that the upper anchorage of the safety belt is behind the child restraint to ensure that the safety belt is routed correctly.
- Make sure that the backrest is in the upright position.

WARNING

Any unused safety belts on the rear seats are a danger to your child when transported in a child restraint on the rear seats. By playing with the safety belts, the child may get tangled up and this could result in severe or fatal injuries.

- Always secure unused safety belts to the rear seat. You can do this by putting them around the head restraints which are furthest away from the installed child restraint and secure the safety belt.

NOTICE

- Make sure not to activate the lockable belt system when you secure the safety belts that are not being used.
- Make sure that the belt is not damaged when installing the child restraint with the safety belt, particularly if you are using the lockable belt system.

Safety notes on using child restraints

 Please read the introductory information and heed the Warnings and Notice ⇒  *Introduction.*



Fig. 28 Never allow children or infants to travel on your lap.

The correct use of child restraints significantly reduces the risk of injury in the event of an accident or collision!

All children, in particular children under the age of 12, must always travel in suitable child restraints on the rear seat.

Only use child restraints that are suitable for the height and weight of the child.

ISOFIX/lower LATCH anchorage points can be used to secure child restraints on the seats without using the vehicle's safety belts. If you do want to install a child restraint using the safety belts instead of ISOFIX/lower LATCH anchorage points, please follow all instructions given by the child restraint manufacturer for guiding the belt around the child restraint and securing the child in the child restraint. Ensure that the child restraint cannot move forward or sideways by more than 2.5 cm (1 inch) after installation.

When installing a child restraint with the safety belt, you must activate the lockable belt system.

Never activate the lockable belt system when installing a booster seat or if a child is traveling without a child restraint.

Once the child restraint is correctly installed, the settings for that seat must no longer be changed. If the seat settings have been changed, the installation of the child restraint must be checked and, if necessary, adjusted.

If a child restraint is installed on a seat, functions such as the massage function ⇒ *Massage feature* or seat heating ⇒ *Seat heating* must not be used on that seat.

Important additional information for installing child restraints on the front passenger seat

If, under exceptional circumstances, you need to install a child restraint on the front passenger seat, read and follow all warnings and instructions here ⇒ [Introduction](#).

You can find additional information on the selection and use of child restraints here:

Transport Canada Information Centre Tel.: 1-800-333-0371 Tel.: 1-613-998-8616 (Ottawa) <http://www.tc.gc.ca/roadsafety>

National Highway Traffic Safety Administration Tel.: 1-888-327-4236 (TTY: 1-800-424-9153) <http://www.nhtsa.gov> <http://www.safercar.gov>

National SAFE KIDS Campaign Tel.: 1-202-662-0600 <http://www.safekids.org>

SafetyBeltSafe U.S.A. Tel.: 1-800-745-SAFE or 1-800-745-7233 (English) Tel.: 1-800-747-SANO or 1-800-747-7266 (Spanish) <http://www.carseat.org>

Volkswagen Customer CARE Tel.: 1-800-822-8987

⚠ DANGER

The use of rear-facing child restraints or infant carriers on the front passenger seat can cause severe or fatal injuries.

- Always install rear-facing child restraints or infant carriers on the rear seat.

⚠ WARNING

Transporting children without a child restraint or with an unsuitable child restraint, or incorrectly installing a child restraint, increases the risk of severe or fatal injuries in the event of an accident or collision.

- Only use child restraints that are suitable for the child and that comply with the regulations set out by FMVSS 210 (CMVSS 213 in Canada).
- Only use child restraints that sit on the seat cushion of the vehicle.
- When installing the child restraint, follow the instructions given by the manufacturer of the child restraint.
- Always observe all legal requirements regarding the installation and use of child restraints.
- Children under 145 cm (around 4 ft, 9 in) may only be secured and transported in the vehicle with an appropriate child restraint.

- Only one child must be allowed to travel in a child restraint.
- Never drive with children, toddlers or babies on the driver's or a passenger's lap.

⚠ WARNING

Forward-facing child restraints on the front passenger seat may collide with the airbag if it is triggered, which can lead to severe or fatal injuries.

- Always install child restraints on the rear seat.

Securing systems

📖 Please read the introductory information and heed the Warnings and Notice ⇒ ⚠ Introduction.

Different securing systems are used for safe installation of child restraints depending on the country.

Only use the securing systems described here to secure child restraints in the vehicle.

Overview of securing systems

- **ISOFIX/lower LATCH anchorage points**: ISOFIX/lower LATCH anchorage points are attachment systems for quick and secure attachment of child restraints in the vehicle. Attachment using ISOFIX/lower LATCH anchorage points creates a fixed connection between the child restraint and the vehicle.

The child restraint can have two fixed or flexible attachment arms. The attachment arms snap into the ISOFIX/lower LATCH anchorage points that are located between the seat cushion and the rear seat backrest ⇒ *Fastening a Child Restraint with ISOFIX or Lower LATCH Anchorage Point*. Reinforce the attachment using the ISOFIX/lower LATCH anchorage points by attaching with a top tether safety belt or a support bracket, if necessary.

- **Three-point safety belt**: Child restraints can be fastened with a three-point safety belt ⇒ *Securing a child restraint with a safety belt*.

Additional fasteners:

- **Top Tether**: the upper belt is guided over the rear seat backrest and secured to the anchorage point on the rear side of the rear seats using a hook ⇒ *Securing the child restraint with the upper strap (top tether)*. Top tether anchorages are labeled with an anchor symbol.
- **Support base**: some child restraints are supported with a support base on the vehicle floor. The support base reduces the risk of the child restraint tipping forward in the event of a collision. Only use child restraints with a support foot on the front passenger seat and the outer seats in the second row of seats ⇒ ⚠

⚠ WARNING

Incorrect use of the support base can cause severe or fatal injuries.

- Make sure the support base is installed correctly and securely.

Fastening a Child Restraint with ISOFIX or Lower LATCH Anchorage Point

📖 Please read the introductory information and heed the Warnings and Notice ⇒ ⚠ Introduction.

Installing child restraints with ISOFIX/lower LATCH anchorage point

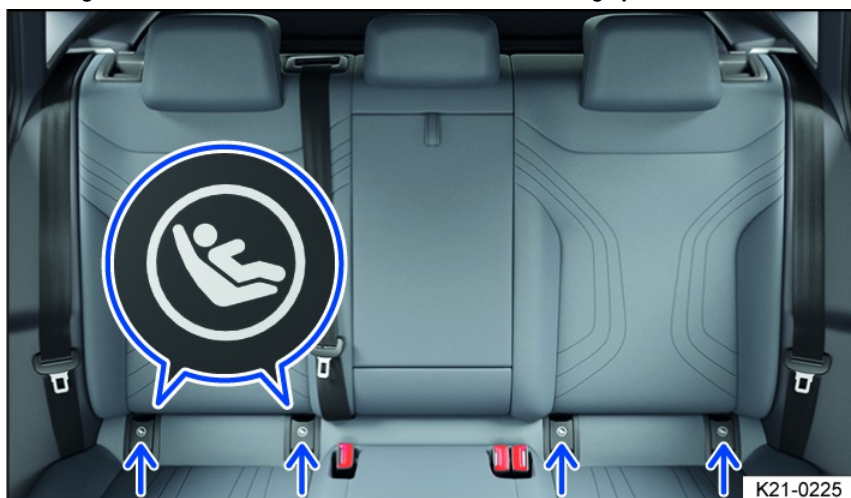

Fig. 29 On the outer seats in the rear bench seat: Designation of the ISOFIX/lower LATCH anchorage points for child restraints.



Fig. 30 General example: fitting a child restraint with attachment arms.

The installation location of the ISOFIX/lower LATCH anchorage points is indicated by a symbol [fig. 29](#).

1. Pay attention to and follow the information → page , *Safety notes on using child restraints*.
2. If necessary, fold down the protective caps of the ISOFIX/lower LATCH anchorage points.
3. Push the attachment arms of the child restraint in the direction of the arrow onto the ISOFIX/lower LATCH anchorage points [fig. 30](#). The child restraint must engage securely and audibly.
4. Pull on both sides of the child restraint to check that the child restraint is securely locked in place.

If the child restraint is equipped with a support foot, this support foot must be positioned securely on the vehicle floor.

Securing the child restraint with the upper strap (top tether)

📖 Please read the introductory information and heed the Warnings and Notice ⇒ ⚠️ *Introduction*.



Fig. 31 On the rear side of the rear bench seat: Top tether anchorages for the top tether safety belt.

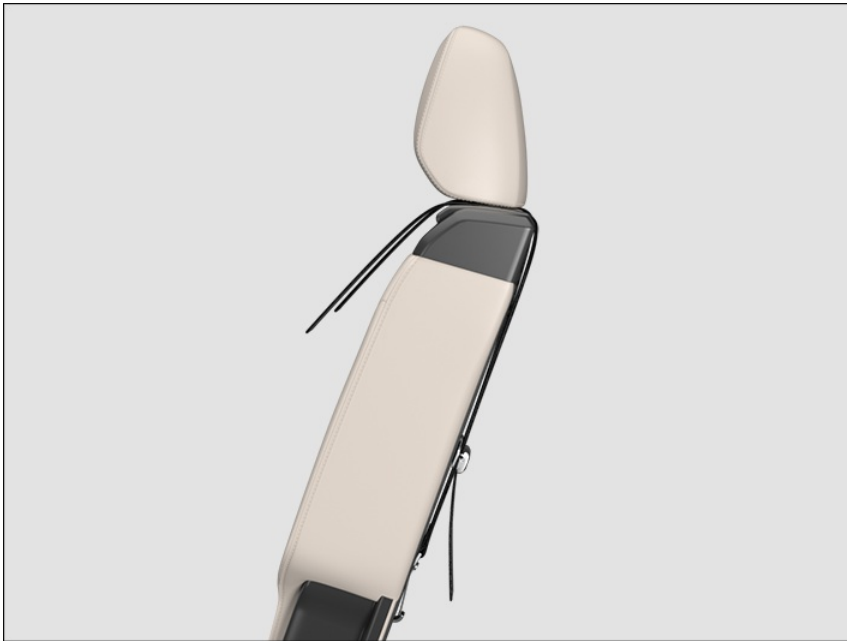

Fig. 32 On the rear side of the rear bench seat: attached top tether safety belt.

Top tether safety belts reduce the forward movement of the child restraint during an accident. This reduces the risk of a head injury to the child.

The anchorages suitable for top tether are labeled with a symbol and may have the label “TOP TETHER” *fig. 31*. Fasten the top tether safety belt only to the top tether anchorages designed for this purpose.

Fastening the top tether safety belt

1. Pay attention to and follow the information → page , *Safety notes on using child restraints*.
2. Prepare the top tether safety belt on the child restraint according to the child restraint manufacturer instructions ⇒ ⚠.
3. If necessary, remove the luggage compartment cover and screen separator.
4. Place the child restraint in the center of the vehicle seat cushion and fasten it securely according to the child restraint manufacturer instructions.
5. If necessary, move the rear seat backrest of the vehicle seat to an upright position and adjust to the backrest of the child restraint.
6. Locate the top tether anchorage for the respective seat *fig. 31*.
7. If necessary, push the head restraint upwards and guide the top tether safety belt of the child restraint to the rear under the head restraint.

Applies to child restraints with a V-shaped top tether safety belt: Check that the top tether safety belt is taut on the seat and is not redirected by the bars of the head restraint.

8. Guide the top tether safety belt of the child restraint back over the seat.
9. Hook the top tether safety belt into the appropriate anchorage marked with “top tether” *fig. 32*.
10. Pull on the top tether safety belt.
11. Check that the hook of the top tether safety belt is closed.
12. Tighten the top tether safety belt according to the child restraint manufacturer instructions ⇒ ⚠.
13. If necessary, guide the head restraint back into the starting position.

⚠ WARNING

Fastening the child restraint incorrectly increases the risk of serious and fatal injuries during an accident.

- Always follow the child restraint manufacturer instructions for fastening the child restraint in the vehicle.
- Never fasten a child restraint without the top tether safety belt if the use of a top tether safety belt is prescribed by the child restraint manufacturer or legally required for the child restraint.
For example, the use of a top tether safety belt in conjunction with a forward-facing child restraint is legally required in Canada.
- Improper fastening of the top tether safety belt can lead to serious injuries during an accident. The top tether anchorages are only approved for correctly installed child restraints.
- Always only fasten a top tether safety belt of a child restraint to a top tether anchorage.
- Never fasten a child restraint top tether safety belt to a tie-down.
- Never fasten a safety belt or another belt of the child restraint to a top tether anchorage.
- Never fasten luggage or other objects to a top tether anchorage.

Releasing the top tether safety belt

1. Release the top tether safety belt according to the child restraint manufacturer instructions.
2. Release the catch on the hook and release the top tether safety belt from the top tether anchorage.

Securing a child restraint with a safety belt

📖 Please read the introductory information and heed the Warnings and Notice ⇒ ⚠️ *Introduction.*

Locking the safety belt

If a child restraint is fastened with a safety belt, the safety belt must be locked. Note the instructions provided by the child restraint manufacturer.

If a safety belt is locked, the belt cannot unwind. A locked safety belt prevents the safety belt being released during the journey, which can mean that the child restraint is no longer sufficiently secured.

1. Pay attention to and follow the information → page , *Safety notes on using child restraints.*
2. If available, adjust the height of the safety belt so that the belt webbing runs naturally along the child restraint without any sharp bends in the webbing.
3. Install the child restraint according to the guide from the child restraint manufacturer and ensure that the safety belt meant for the seat is used.
4. Insert the buckle tongue into the belt buckle belonging to the corresponding seat, until the buckle tongue latches into place.
5. Check that the safety belt is not twisted.
6. Check that the lap section of the safety belt is taut.
7. Completely pull out the shoulder belt section of the safety belt and then let it gently roll up.

While the safety belt is being rolled up, a clicking sound can be heard. Once the safety belt is locked, it cannot be further pulled out.

8. Press the child restraint into the seat and let the safety belt roll up further. If necessary, return the shoulder belt section of the safety belt to the automatic safety belt retractor by hand.
9. Pull the belt guide of the child restraint.

Check that the child restraint cannot move further than 2.5 cm (approx. 1 inch).

Releasing the locked safety belt

The lockable safety belt may only be used to fasten certain child restraint systems in the vehicle. An activated locking mechanism must be released when a vehicle occupant fastens their safety belt.

1. Release the safety belt from the belt buckle.
2. Remove the child restraint according to the instructions from the child restraint manufacturer.
3. Press the red button in the belt buckle and guide the safety belt back fully by hand.

The safety belt is no longer locked.

Keep any safety belts that are not being used out of the reach of children



Fig. 33 Keep any safety belts that are not being used away from children.

Secure any safety belts not being used to prevent a child from playing with the safety belt and getting caught in it. The procedure for securing a safety belt that is not being used depends on the seating position.

To secure a safety belt that is not being used for one of the outer seats:

1. Position the safety belt around the head restraint of the center seating position *fig. 33*.
2. Make sure that the safety belt is out of range of any children so that children cannot touch it or play with it.
3. Make sure that the safety belt is not blocking the lower anchors.

If the anchor points are blocked, this may mean that you cannot install the child restraint properly in the anchor points.

4. Do not activate the lockable safety belt.

Otherwise, it is very difficult to retract the safety belt into its normal position. You should not hear any clicking noises when the safety belt is retracted.

To secure a safety belt that is not being used for the middle seat:

1. Insert the safety belt buckle tongue into the belt buckle for that seat *fig. 33*.
2. Pull the shoulder strap on the safety belt out fully to activate the lockable safety belt. You should hear a clicking noise when the safety belt is rolled up again.
3. Let the safety belt roll up fully. Pull the safety belt to make sure that the lockable safety belt is activated and the safety belt is properly fastened and tightened so that the child cannot get hold of the belt or play with it.

If a child is secured on a seat in the second row, adjust the position in front of the child restraint to ensure that the child has enough space. For example, adjust the front passenger seat to the size of the child and the child directly behind them. Always pay attention to the correct seating position \Rightarrow *Seating position*.

If no child restraints are needed, move all the safety belts back into their normal storage positions so that the safety belts are available for normal use.

Installing on the center seating position

When installing a child restraint on the center seating position, it is especially important to install correctly because this seating position is narrower than both of the outer seats. If the child restraint is wider than the seat surface, the belt buckle of the adjacent seating position may be covered and could then be damaged. When installing child seats, always ensure that all belt buckles are easily accessible.

- If nothing else is specified by the child restraint manufacturer, the child restraint must rest close against the backrest and seat surface and must not overlap se surfaces.
- The child restraint must be installed straight and centered on the seating position, and it must not be able to move more than 2.5 cm (approx. 1 inch).
- The child restraint must not rest on the belt buckles.
- When installing multiple child restraints, the child restraints must not become caught on one another.

In some cases, even if a child restraint is installed correctly on the center seating position, it may cover the belt buckles and could then damage them and make the belt buckles unusable. This can occur if the child restraint slides on the seat surface while driving. Therefore, check the position of the child restraint regularly to ensure that the belt buckles are neither covered nor damaged.

WARNING

A child that is in a child restraint that has been secured with the anchor points or with a safety belt may play with any unused safety belts on the rear seat and get tangled up, which could result in serious or even fatal injuries.

- Always keep any safety belts for the rear seats that are not being used out of the reach of children.

Securing a booster seat with a safety belt

 Please read the introductory information and heed the Warnings and Notice \Rightarrow  *Introduction*.



Fig. 34 Correctly fastened child on a booster seat.

Children between the ages of around 8 and 12 are best protected when they travel on a booster seat that is suitable for their age and height.

The safety belts of the vehicle generally only fit children 145 cm (approx. 4 ft, 9 in) tall or taller. Booster seats ensure that children under this height can be correctly fastened using the safety belt.

- Never activate the lockable belt system when securing a child with a booster seat.
- The upper area of the belt must always be positioned on the child's shoulder. Ensure that the belt does not rest on the child's face or neck.
- The lap belt must always run across the child's lap. It must never run across the child's stomach.

Children over 145 cm (approx. 4 ft, 9 in) tall can generally be fastened with the safety belt. Pay attention to the information at [⇒ Safety belt positioning](#).

Your child no longer needs a booster seat if they are taller than 145 cm (approx. 4 ft, 9 in) and the following conditions are met:

- The child can sit with their back fully against the backrest.
- The child's knees bend over the edge of the seat.
- The child's feet sit fully flat on the vehicle floor.
- The child can comfortably stay in this position for the entire journey.

Children aged 12 or under must always travel on a rear seat.

WARNING

Not using a booster seat or incorrectly using a booster seat or safety belt can cause severe or fatal injuries in the event of an accident or collision.

- Always observe all instructions regarding the installation and use of child restraints and booster seats.
- If, under exceptional circumstances, you need to install a booster seat on the front passenger seat, ensure that the PASSENGER AIR BAG **OFF**  indicator light turns on and remains on.

In case of an emergency

Securing yourself and the vehicle

Follow all legal regulations regarding securing a vehicle during a breakdown. For example, in many countries you must switch on the emergency flashers and wear a reflective vest [⇒ Emergency equipment](#).

Checklist

For your own safety and the safety of your passengers, follow the points below in the order they are given [⇒ !\[\]\(274fd520e03b61c1b9ffc861754cacdc_img.jpg\)](#):

1. Park your vehicle a safe distance from traffic and on suitable ground. Observe all important information on parking when doing so [⇒ Parking](#).
2. Switch on the emergency flashers [⇒ Center console](#).
3. Have all vehicle occupants exit the vehicle on the side facing away from traffic and move to a safe area, such as behind a guard rail. Follow the local regulation regarding wearing a reflective vest.
4. Set up the warning triangle to warn others on the road about the vehicle.
5. Observe the safety instructions [→ page , Safety precautions for working in the hood space](#).
6. If necessary, contact an authorized Volkswagen dealer or authorized Volkswagen Service Facility for assistance. Volkswagen recommends contacting the Volkswagen emergency assistance service.

When the emergency flashers are switched on, for example while towing the vehicle, you can indicate any turns or lane changes using the turn signal lever. The emergency flashers will stop temporarily.

Read and observe the important information about towing [⇒ !\[\]\(683dba75afe26e28cd4de5730b776760_img.jpg\) Introduction](#).

Switch on the emergency flashers in the following situations, for example:

- To warn traffic behind your vehicle if the traffic ahead slows suddenly or you reach the end of a traffic jam.
- If there has been an accident.
- If the vehicle malfunctions.
- When towing.

Always follow the applicable local requirements for use of the emergency flashers.

If the emergency flashers do not work, others on the road must be informed about the stalled vehicle in some other way that meets the applicable legal regulations.

WARNING

A stalled vehicle increases the risk of a crash that could cause injury to you, your vehicle occupants, or others on the road.

- Stop the vehicle as soon as it is safe to do so.
- Park the vehicle a safe distance from moving traffic.

- Switch on the emergency flashers.
- Never leave any persons, particularly children or people requiring assistance, in the vehicle. This is especially true when the doors are locked. Individuals locked in the vehicle could be exposed to very high or very low temperatures.

WARNING

Failing to heed this checklist that is provided for your own safety can cause accidents and serious injuries.

- Always follow the activities in the checklist and follow the general safety precautions.

NOTICE

When pushing the vehicle by hand, do not press on the taillights, the rear spoiler, or large pieces of sheet metal. Doing so could cause vehicle damage and the rear spoiler may detach.

 **The 12 V vehicle battery will drain if the emergency flashers remain on for a long period of time, even if the ignition is switched off.**

 **Depending on vehicle equipment, the brake lights may blink quickly if you brake hard while driving at speeds above approx. 50 mph (approx. 80 km/h) or brake the vehicle to a complete stop. This is done to warn traffic behind your vehicle. If the braking continues, the emergency flashers will switch on automatically when the vehicle speed is below approx. 6 mph (approx. 10 km/h). The emergency flashers will switch off automatically when you accelerate.**

What to do in the event of an accident or fire

Checklist of what to do after an accident

In the event of an accident, for your own safety and the safety of your passengers, follow the points below in the order in which they are given ⇒ :

1. End drive-ready mode.
2. Switch on the emergency flashers ⇒ *Center console*.
3. Set up the warning triangle to warn others on the road about the vehicle.
4. If necessary, move people away from the danger zone and apply first aid.
5. Report the accident to the fire department. Inform the fire department that an electric vehicle is involved in the accident.
6. Wait at the location of the accident for the rescue services to arrive.
7. Inform the emergency personnel on site, and any people affected by the accident, that an electric vehicle is involved.

Checklist of what to do in the event of a fire

In the event of a vehicle fire, for your own safety and the safety of your passengers, follow the points below in the order in which they are given ⇒ :

1. End drive-ready mode.
2. If possible, switch on the emergency flashers ⇒ *Center console*.
3. If possible, set up the warning triangle to notify others on the road about the vehicle.
4. If necessary, move people away from the danger zone and apply first aid.
5. Report the fire to the fire department. Inform the fire department that an electric vehicle is involved in the accident.
6. Wait for the emergency personnel at a sufficient distance from the vehicle.
7. Inform the emergency personnel on site, and any people affected by the accident, that an electric vehicle is involved.
8. Do not try to put out the fire yourself.
9. Do not stand near the burning vehicle.

WARNING

Failing to heed this checklist that is provided for your own safety can cause accidents and serious injuries.

- Always follow the activities in the checklist and follow the general safety precautions.

WARNING

In the event of a fire, an explosion and any harmful substances that are released can cause serious injuries.

- Never stand near the burning vehicle.

 **If the system detects an accident, the high-voltage battery is automatically deactivated.**

- If the high-voltage battery is deactivated, consult an authorized Volkswagen dealer or authorized Volkswagen Service Facility and have the high-voltage battery repaired.

Emergency equipment

First aid kit

Depending on the vehicle equipment and country of use, the first aid kit may be in a storage compartment, in a holder in the luggage compartment, under the luggage compartment floor, or in the vehicle interior.

The first aid kit must meet the legal regulations.

- Note the expiration date of the contents.
- Replace contents after use, if necessary, and put the first aid kit securely back into place.

Warning triangle



Fig. 35 In the trunk lid: Holder for the warning triangle.

Depending on the country and the vehicle equipment, the warning triangle may be located in the trunk lid *fig. 35*.

1. With the trunk lid open, hold the sleeve of the warning triangle by the recess and turn it 90° towards the front of the vehicle.
2. Remove the sleeve through the opening.
3. After use, store the warning triangle back in the sleeve and insert the sleeve back into the holder.

The warning triangle must meet the legal regulations.

Reflective vest

Depending on the vehicle equipment and country of use, the safety vest may be in a storage compartment in the front door trim panel or in the glove compartment
 ⇒ *Driver door*, ⇒ *Passenger's side*.

The reflective vest must meet the legal regulations.

Fire extinguisher

Depending on the vehicle equipment and country of use, a fire extinguisher may be located in a holder in the footwell under the front passenger seat.

The fire extinguisher must meet the legal regulations, always be ready to operate, and be checked regularly – see inspection seal on the fire extinguisher.

⚠ WARNING

Objects that are loose or secured incorrectly can be thrown around the vehicle interior during sudden driving or braking maneuvers or in a collision and cause serious injuries.

- Always position the first aid kit, warning triangle and fire extinguisher securely in the holders provided in the vehicle.
- Store the reflective vest in a storage compartment so that it is easy to access.

Information Call, Roadside Assistance Call and Emergency Call Service



Fig. 36 Located on the roof console: Emergency Call Service button (behind a button cover) and indicator light.



Fig. 37 Located on the roof console: Emergency Call Service button.



Fig. 38 In the overhead console: Controls for the information call and roadside assistance call.

 Information call.

 Roadside assistance call.

The [fig. 36](#), [fig. 37](#), [fig. 38](#) roof console controls can be used for voice services, depending on the vehicle equipment and country of use. The required connection is produced by a control module installed by the manufacturer.

Indicator lights for the Emergency Call Service

An indicator light *fig. 36* (arrow) for voice and data transmission services is located in the control panel. The indicator light comes on in different colors and light patterns depending on the vehicle operating status of the Emergency Call Service:

 The indicator light does not light up: The vehicle is offline and has no connectivity.  The red indicator light comes on and remains on: system error. The Emergency Call Service is limited or not available.  The green indicator light lights up: Displays the availability of mobile radio signal. Does not display whether VW Car-Net services have been purchased and are active, except for the Emergency Call Service.  The indicator light blinks green: there is a call in progress.

Information call

- With an information call, a call can be made to the VW Car-Net call center for questions regarding VW Car-Net services.
- The contact person will communicate in the language of the country in which the vehicle was registered with VW Car-Net, or in the language of the country for which the vehicle was produced.

Roadside assistance call

- If you break down, you can contact an authorized Volkswagen dealer or authorized Volkswagen Service Facility for assistance with the roadside assistance call.
- Some vehicle data, e.g. its current location, is transferred in parallel to the voice call.
- The contact person will communicate in the language of the country in which the vehicle was registered with VW Car-Net, or in the language of the country for which the vehicle was produced.

Emergency Call Service

- Using the Emergency Call Service, assistance can be organized as quickly as possible in dangerous situations.
- The Emergency Call Service is only available if a corresponding license is acquired.
- If the Emergency Call Service is triggered, a call to the VW Car-Net call center will be made.
- If an emergency call is triggered manually or by a collision with airbag deployment or safety belt pretensioner deployment, data that is relevant to the emergency call, such as the vehicle's current location, is automatically transmitted ⇒ *Customer information*.
- The contact partner will communicate in the language that is set in the vehicle's Infotainment system. If this language is not available at the current emergency call location, English will be used.

WARNING

The following conditions may restrict or prevent a manual or automatic emergency call:

- The emergency call location is in an area with no cell phone and satellite reception, or insufficient reception.
- You are in a location where there is sufficient mobile phone and satellite reception, but the telecommunications provider's mobile communications network is unavailable.
- The Emergency Call Service is not permitted by law in some countries.
- VW Car-Net has not been activated.
- No valid license for the use of the Emergency Call Service has been acquired or the license has expired.
- The vehicle components required for manual or automatic emergency calls are damaged or do not have sufficient power.
- The vehicle's ignition is not switched on.

Triggering an emergency call manually

1. Press on the button cover briefly and fold the cover downward *fig. 36*.
2. Press the emergency call button *fig. 37* until the green indicator light starts to flash.

The emergency call is triggered and a voice call to the VW Car-Net call center is established.

If you pressed the emergency call button by mistake, cancel the emergency call immediately:

1. Press the emergency call button again until the indicator light remains green.

Automatic emergency call

The automatic emergency call is only triggered when the ignition is on.

A call will automatically be made to the VW Car-Net call center immediately after the airbags or safety belt pretensioners deploy. The automatic emergency call cannot be stopped by pressing the emergency call button *fig. 37*.

If questions from the VW Car-Net call center remain unanswered, rescue operations will automatically start.

Integrated battery

The integrated battery ensures that the Emergency Call Service will still be available for some time if the 12 V vehicle battery is disconnected or faulty.

If the integrated battery is drained or faulty, a message indicating this will be displayed in the instrument cluster. If this message is shown, immediately consult an authorized Volkswagen dealer or authorized Volkswagen Service Facility and have the integrated battery replaced. Volkswagen recommends contacting an authorized Volkswagen dealer or authorized Volkswagen Service Facility.

 **Have the integrated battery checked, and if necessary, replaced by an authorized Volkswagen dealer or authorized Volkswagen Service Facility after approximately three years. Volkswagen recommends contacting an authorized Volkswagen dealer or authorized Volkswagen Service Facility.**

Data transmission

The available data will be sent to the VW Car-Net call center during an emergency call to determine what rescue measures are needed.

The data regarding the location of the vehicle is continuously overwritten, so that only the ten most recent saved locations as required for the Emergency Call Service to function are available. The vehicle cannot be tracked on a continuous basis.

The emergency call data is only processed to ensure the proper function of the Emergency Call Service.

The following data will be sent:

- The current vehicle position at the time the emergency call was triggered
- Nine other vehicle positions shortly before the emergency call was triggered (from the route driven, a few km (around 2 miles)).
- Vehicle Identification Number (VIN)
- Type of vehicle drive.
- Vehicle model
- Trigger type (automatic or manual)
- Call type.
- Direction in which the vehicle was moving at the time the emergency call was triggered.
- Accident severity.
- Accident direction.
- Type of vehicle involved in the accident.
- Time of impact
- Temperature.
- Road type.
- Reliability of the positioning data
- Data set version.
- Counter of the data sets transmitted per call
- Calculated number of passengers.
- Language selected in the Infotainment system.
- Optional data ID.

 **The Emergency Call Service function may be limited by any after-market Infotainment systems that are installed.**

Troubleshooting

Emergency Call Service malfunction

The red indicator light in the emergency call button comes on and remains on . The message  Error: Emergency call function. Service vehicle may also be displayed in the instrument cluster.

There is a system error with the Emergency Call Service. You may not be able to make an emergency call.

1. Contact an authorized Volkswagen dealer or authorized Volkswagen Service Facility immediately and have the fault rectified. Volkswagen recommends contacting an authorized Volkswagen dealer or authorized Volkswagen Service Facility.

Emergency Call Service limited

The red indicator light in the emergency call button comes on and remains on . The message  Emergency call function limited. Service vehicle may also be displayed in the instrument cluster.

The Emergency Call Service function has restricted availability. For example, you cannot make a voice call to the VW Car-Net® call center.

1. Contact an authorized Volkswagen dealer or authorized Volkswagen Service Facility immediately and have the fault rectified. Volkswagen recommends contacting an authorized Volkswagen dealer or authorized Volkswagen Service Facility.

Controls are responding differently than expected

Moisture, dirt and grease may limit the functioning of the controls.

1. Always keep the control panels clean and dry.

Opening and Closing

Vehicle key

Vehicle key functions

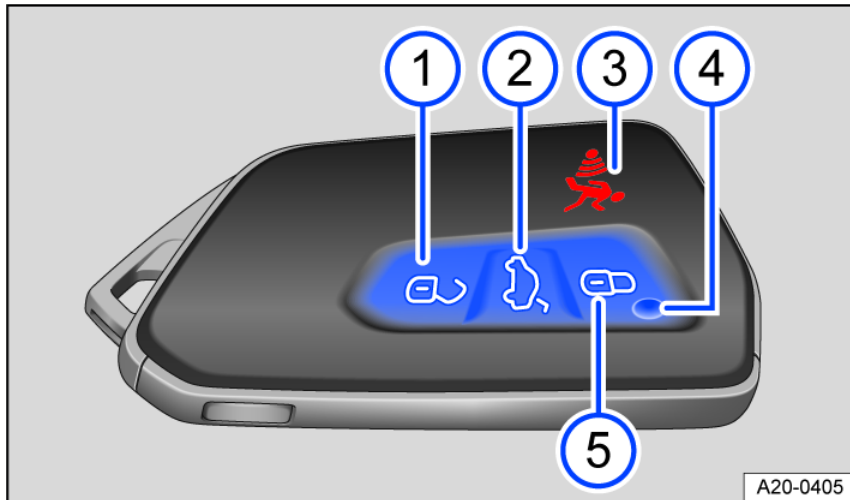



Fig. 39 Vehicle key.

- ① Unlock the vehicle. All turn signals will flash twice.
- ② Unlock the trunk lid separately. All turn signals will flash twice. To do this, briefly press and hold the button.
- ③ Panic button (depending on vehicle equipment).
- ④ Indicator light: Will blink when a button is pressed if all doors and the trunk lid are closed.
- ⑤ Lock the vehicle. All turn signals will flash once.

Panic button (depending on vehicle equipment)

Only use the panic button  in case of an emergency. When you press the panic button, the horn will sound and the vehicle lights will flash. Pressing the panic button again switches off the alarm.

⚠ WARNING

If you leave vehicle keys unattended in the vehicle, children or unauthorized people could lock the doors and/or the trunk lid, activate drive-ready mode, or switch on the ignition and thereby activate electrical equipment, such as the power windows. This can cause accidents and serious or fatal injuries.

- Always take all vehicle keys with you when leaving the vehicle.

⚠ WARNING

If you leave children, people requiring assistance or animals unattended in the vehicle, they may accidentally set the vehicle in motion or be subjected to very high or low temperatures. There is a risk of accidents and serious or fatal injuries.

- Never leave children, people requiring assistance or animals unattended in the vehicle.

ⓘ NOTICE

External influences may limit the functionality of the remote control vehicle key and damage it.

- Protect the vehicle key from moisture and strong impacts.

 Regular use of comfort systems and other usage patterns shorten the service life of the button cell in the vehicle key.

Emergency key

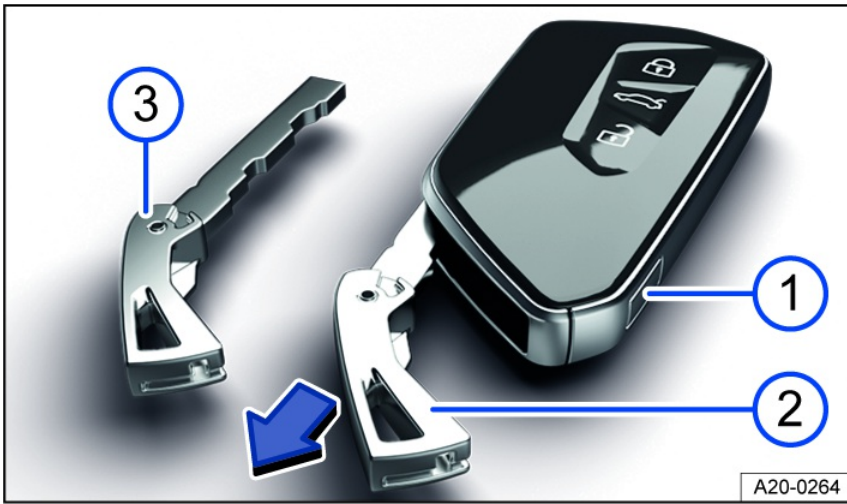

Fig. 40 Vehicle key: releasing the emergency key.

- ① Briefly press the release button. The key ring will fold open.
- ② Press the release button and pull out the emergency key in the direction of the arrow.
- ③ Emergency key.

There is an emergency key located in the vehicle key that can be used to manually unlock and lock the vehicle *fig. 40*.

Replacing the button cell battery

Volkswagen recommends having the button cell changed by suitably qualified professionals. Volkswagen recommends contacting an authorized Volkswagen dealer or authorized Volkswagen Service Facility ⇒ ⚠.

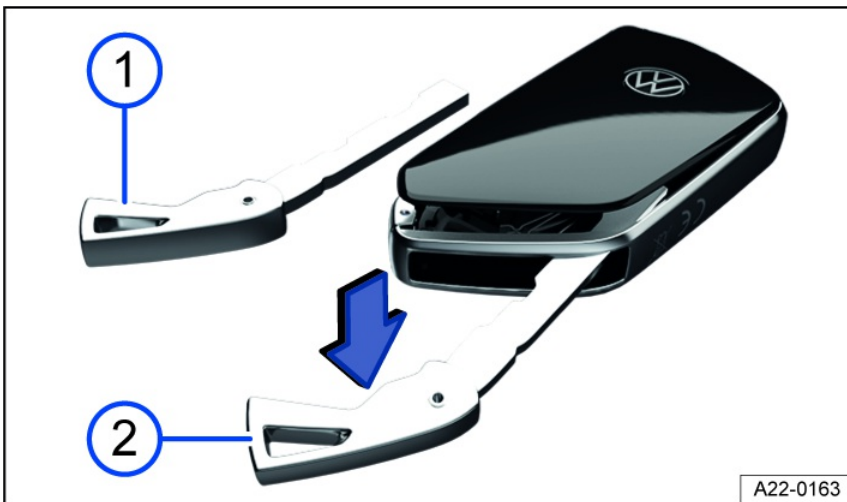



Fig. 41 Remote control vehicle key: opening the battery compartment cover.

- ① Emergency key.
- ② Lever out the cover.



Fig. 42 Vehicle key: replacing the button cell battery

1. Remove the emergency key [fig. 41](#) , ⇒ [Emergency key](#).
2. Insert the spare key in the slot, push it in the direction of the arrow and lever out the cover [fig. 41](#).
3. Lift the button cell battery out of the battery compartment [fig. 42](#) , ⇒ .
4. Press the new button cell battery into the battery compartment.
5. Press the cover onto the housing [fig. 42](#) , ⇒ .
6. Store the emergency key ⇒ [Emergency key](#).
7. Dispose of drained battery in a way that will not harm the environment.

DANGER

If button cell batteries are swallowed or enter the windpipe, serious or fatal injuries will occur within a very short time due to choking or internal burns.

- Seek medical assistance immediately if you suspect that a button cell battery has been swallowed.
- Always keep the remote control and key fob with button cell batteries out of the reach of children.

NOTICE

If the button cell battery is replaced incorrectly or a battery is unsuitable, it can damage the vehicle key.

- Only replace a drained battery with a new battery of the same voltage, size, and specification.
- Make sure the battery is facing in the right direction when inserting it.
- If the battery cover cannot be closed, do not use the remote control.

 The type of batteries used in the remote control of your vehicle key can contain perchlorate. This requires special handling. Observe all legal requirements regarding the handling and disposal of these batteries ⇒ [Disposal of old batteries and electronic devices](#). Volkswagen recommends having this service carried out for you by suitably qualified professionals. Volkswagen recommends contacting an authorized Volkswagen dealer or authorized Volkswagen Service Facility.

Synchronizing a vehicle key

If the vehicle cannot be unlocked or locked using the vehicle key, synchronize the vehicle key or replace the button cell battery ⇒ [Replacing the button cell battery](#).

Synchronizing a vehicle key

1. Stand next to the vehicle.
2. Press the  button on the vehicle key twice, quickly.

Or:

1. Remove the emergency key ⇒ [Emergency key](#).
2. If necessary, remove the cap from the driver's door handle ⇒ [Locking the front passenger door and rear doors in an emergency](#) .
3. Press the  button on the vehicle key.
4. Unlock the vehicle using the emergency key.
5. Switch the ignition on.

To switch on the ignition, an emergency start must be performed. ⇒ [Troubleshooting](#).

This completes the synchronization.

Troubleshooting

Vehicle cannot be locked or unlocked

Remote control is disrupted by objects, poor weather conditions or transmitters on the same frequency band close to the vehicle (e.g. cell phones), as well as by a drained button cell.

The central locking switches off briefly to protect it from overloading.

1. Close the driver door.

Or: Synchronize the vehicle key ⇒ [Synchronizing a vehicle key](#) .

Or: Change the battery cell in the vehicle key ⇒ [Replacing the button cell battery](#) .

The indicator light is not blinking

If the indicator light in the vehicle key does not blink when you press one of the buttons, then the button cell battery in the vehicle key must be replaced.

“Keyless Access” with push-button start

Introduction

Keyless Access makes it possible to unlock and lock the vehicle without actively using the key. A valid vehicle key must be present within the vicinity of the vehicle to use this function.

Unlocking or locking using Keyless Access

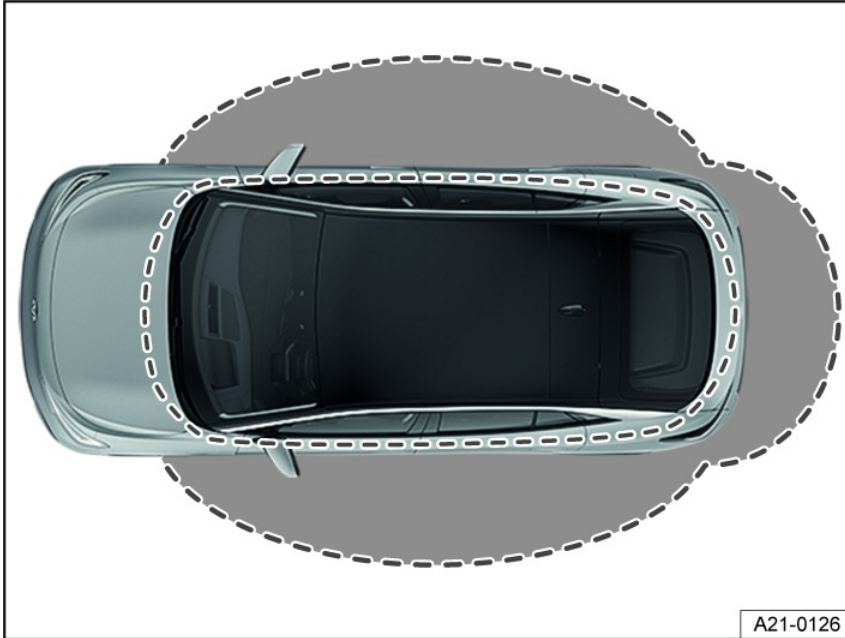

Fig. 43 Keyless Access: general example of the sensor ranges.

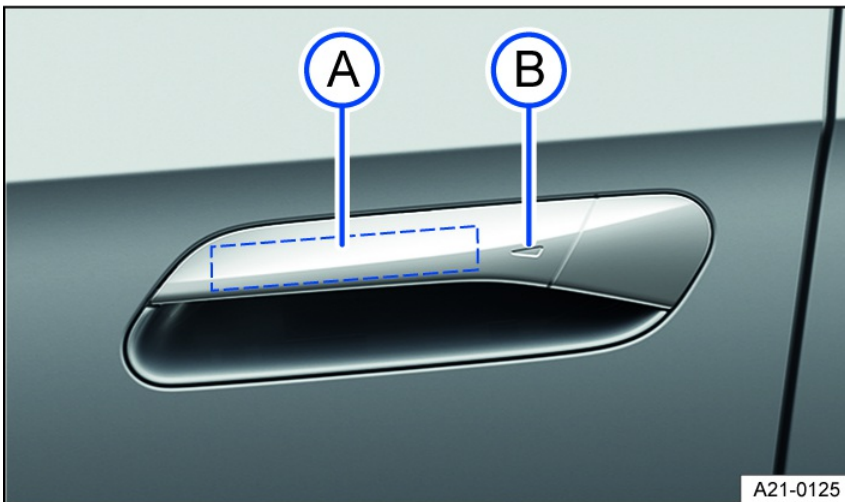



Fig. 44 In door handle: sensors.

-  Sensor surface on the inside of the door handle.
-  Sensor surface on the outside of the door handle.

Configuring Keyless Access

The behavior of Keyless Access can be set in the Vehicle menu in the Infotainment system.

If the Keyless Access function is deactivated, it may be subject to functional limitations.

Unlocking the vehicle

1. Touch the sensor on the inside of the door handle [fig. 44](#).
 - All turn signals will flash twice.
 - If the sensor is touched twice, the entire vehicle will be unlocked.

Unlocking the vehicle upon approach

The vehicle can be unlocked upon approach. To do so, the function must be activated in the Infotainment system and the vehicle key must be within the sensor

range of the vehicle.

- If the vehicle key is detected within the range of any of the sensors, the vehicle is then unlocked [fig. 43](#). All turn signals will flash twice.

If the vehicle is not unlocked for a long period of time, the "Unlocking the vehicle upon approach" function is deactivated. The function is reactivated the next time the vehicle is locked.

If single door unlocking is activated in the central locking settings in the Infotainment system, this may restrict the "Unlocking the vehicle upon approach" function.

Locking the vehicle

1. Park the vehicle.
2. Touch the sensor on the outside of the door handle [fig. 44](#).

All turn signals will flash once.

The unlock function is deactivated for several seconds so that you can check if the vehicle locked correctly.

Unlocking the trunk lid

If the vehicle is locked and a vehicle key is within the trunk lid sensor range, the trunk lid will unlock automatically when opened. After closing, the trunk lid will lock again.

Please note: If Central locking for all doors and Keyless Access unlocking upon approach are activated in the Infotainment system, the vehicle remains unlocked after opening and closing the trunk lid. The vehicle must be actively locked.

Deactivating Keyless Access temporarily

The Keyless Access with push-button start unlocking function can be temporarily deactivated.

1. Lock the vehicle with the  button on the vehicle key.
2. Within five seconds of locking the vehicle, touch the sensor on the outside of the door handle once [fig. 44](#).

All turn signals will flash once.

Keyless Access is now temporarily deactivated.

3. To check that it has actually been deactivated, wait at least 10 seconds and then pull on the door handle.

The door should not open.

The next time the vehicle is unlocked, you must use the electronic vehicle key. Keyless Access will be reactivated the next time the vehicle is unlocked.

Deactivating Keyless Access permanently

Keyless Access can also be deactivated permanently in the Infotainment system.

 If Keyless Access is deactivated, the sensor-controlled opening and closing of the trunk lid \Rightarrow *Trunk lid with Easy Open motion sensor* is likewise deactivated depending on the vehicle equipment, even if the function is set to "Active" in the vehicle menu.

Troubleshooting

If Keyless Access is not working

The sensor function may be impaired if the sensor is dirty.

1. Clean the sensors.

If all turn signals flash four times

The vehicle key that was last used is still in the vehicle.

1. Remove the key and lock the vehicle.

Automatic sensor deactivation

The sensors will deactivate automatically under the following conditions:

- If the vehicle is not unlocked or locked for a long period of time
- If a sensor is triggered too frequently

Reactivating the sensor pads:

1. Unlock the vehicle using the  button on the vehicle key.

Valid vehicle key cannot be detected

The yellow indicator light turns on. A message will also appear in the instrument cluster display.

The vehicle key is no longer in the vehicle or within range of the sensors.

1. Do not end drive-ready mode.

2. Bring the vehicle key back into the vehicle or within range of the sensors.

If the problem persists, contact an authorized Volkswagen dealer or authorized Volkswagen Service Facility. Volkswagen recommends contacting an authorized Volkswagen dealer or authorized Volkswagen Service Facility.

NOTICE

Strong streams of water or vapor could activate the sensors in the door handles if a valid vehicle key is located near the vehicle. This may cause the windows to open and moisture may enter the vehicle interior. This could lead to damage to the vehicle interior.

- Never direct the jet of a high pressure cleaner or a steam jet directly towards the sensors in the door handles.

 If at least one window is open and the sensors in one door handle are permanently activated, then all windows will close.

 If the **Keyless faulty. message appears in the ID. cockpit, there may be a malfunction in Keyless Access with push-button start. Contact an authorized Volkswagen dealer or authorized Volkswagen Service Facility. Volkswagen recommends contacting an authorized Volkswagen dealer or authorized Volkswagen Service Facility.**

 The **Keyless Access with push-button start may not function correctly if another signal, e.g. from a cell phone in the immediate vicinity, interferes with the vehicle key or if the vehicle key is covered by an object, such as a metal case. If there is no remote control vehicle key in the vehicle or the key is not detected, a corresponding message appears in the ID. cockpit.**

Doors and central locking button

Introduction

The doors can be manually locked and in some cases unlocked, for example if the vehicle key or the central locking system is malfunctioning.

The central locking system allows you to unlock and lock all doors, the trunk lid, and the battery charging flap from one location.

The vehicle can be locked when the ignition is switched off or if the driver has exited the vehicle when the vehicle's drive system has been deactivated.

An image in the ID. cockpit indicates if one or more doors are not closed correctly.

 Do not continue driving!

1. Safely park the vehicle, if necessary.
2. Open the respective door and close it again.

The image is also displayed when the ignition is switched off, and it turns off several seconds after the doors are closed and the vehicle has been locked.

WARNING

If a door is not closed correctly, it can open suddenly while driving and cause serious or fatal injuries.

- Stop immediately and close the door.
- When closing the door, make sure it engages securely and completely. When closed, the door must be flush with the areas of the vehicle body that are around the door.

WARNING

When the door is being held open by the door arrester, it may close by itself in high winds or on inclines, which can cause serious injuries.

- Always hold the door handle firmly when opening and closing the door.

WARNING

Opening and closing the doors and trunk lid without due care can be dangerous and result in serious injuries.

- Do not open or close the doors and trunk lid if anyone is in the way.

WARNING

The central locking system locks all the doors. In case of an emergency or accident, locked doors can make it more difficult for first responders to access the vehicle interior. When the vehicle is locked from the outside, the doors and power windows cannot be opened from the inside. There is a risk of serious or fatal injuries.

- Never leave children, people requiring assistance or animals unattended in the vehicle.

WARNING

All doors can be locked from the inside using the central locking button. Otherwise, children, people requiring assistance or animals could be locked inside the vehicle. In an emergency, they may not be able to exit the vehicle without assistance or help themselves. Otherwise, they may be subjected to very high or low temperatures. There is a risk of serious or fatal injuries.

- Never leave children, people requiring assistance or animals unattended in the vehicle.

NOTICE

Removing caps without due care may result in damage to the vehicle.

- When using the emergency locking or emergency unlocking feature, remove and reinstall the parts carefully and correctly.

 **When the vehicle is locked from the inside, it reduces the risk of opening the doors unintentionally and of unauthorized people entering the vehicle.**

 **People locked inside the vehicle can unlock the doors in an emergency by firmly pulling the door opening lever twice. To do so, you must pull beyond a noticeable resistance.**

Opening the doors

 Please read the introductory information and heed the Warnings and Notice ⇒  and  Introduction.

Opening the doors from the outside

There is a button on the inside of the door handles.



1. Unlock the vehicle using the remote control vehicle key.
2. Grasp the door handle, pressing and holding the button on the inside of the door handle whilst doing so.
3. Pull open the door with the door handle.

Opening the doors from the inside

1. Pull the door opening lever until you feel resistance and push open the door. Do not pull the door opening lever beyond the point of resistance.

 **If the vehicle has been locked from the outside, the door opening lever must be pulled twice, as far as it goes, in order to open the door from the inside.**

Indicator light in the driver's door

 Please read the introductory information and heed the Warnings and Notice ⇒  and  Introduction.

The indicator light for the central locking system is located in the driver's door.

The indicator light shows the status of the central locking system for around 30 seconds after the vehicle is locked.

The red LED light blinks at short intervals for around 2 seconds.

The status of the central locking system is then displayed for around 28 seconds:

Vehicles without SAFELOCK

- If the red LED light blinks at long intervals, the vehicle is locked.

After around 30 seconds, the LED light blinks at slow intervals.

Special conditions

If the red LED light comes on continuously, there is a fault in the central locking system or the anti-theft alarm system.

Automatic locking and unlocking

 Please read the introductory information and heed the Warnings and Notice ⇒  and  Introduction.

Depending on how your vehicle is equipped, settings for the central locking can be configured in the Vehicle settings menu in the Infotainment system.

Automatic locking (Auto Lock)

The vehicle locks automatically at speeds of about 15 km/h (9 mph) or higher. If the vehicle is locked, the  indicator light will turn yellow in the central locking button.

Automatic unlocking (Auto Unlock)

If one of the following conditions apply, all doors and the trunk lid will unlock automatically:

- If the electronic parking brake is switched on and the ignition is switched off.
- **Or:** if the door handle has been pulled. This applies at speeds up to 15 km/h (9 mph).
- **Or:** if airbags have deployed during a collision.

 The Auto Unlock function makes it possible for first responders to access the inside of the vehicle.

Control for central locking

 Please read the introductory information and heed the Warnings and Notice  and  Introduction.



Fig. 45 In the driver door: Control for central locking.

 Indicator light in the control panel for central locking.

Depending on the country, the control for central locking may also be located on the front passenger door.

If the vehicle is locked from the outside with the vehicle key, the control for central locking is not activated.

If the vehicle is locked from the inside using the control for central locking, then:

- The yellow indicator light  in the control comes on if all the doors are shut and locked *fig. 45*.

The doors can be opened from the inside by pulling the door handle. The indicator light  in the control turns off. The unopened doors and the trunk lid will remain locked and cannot be opened from the outside.

The driver's door will not lock if it is open.

Opening and closing the driver's door in an emergency



 Please read the introductory information and heed the Warnings and Notice  and  Introduction.



Fig. 46 Driver's door handle: prying off the cap.

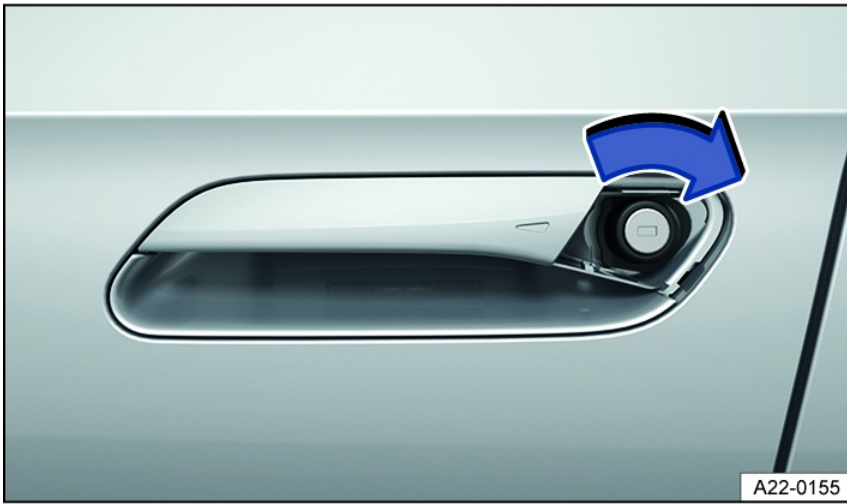

A22-0155

Fig. 47 Emergency locking of driver door.

1. Use the vehicle key to pry the cap off in the direction of the arrow *fig. 46*.
2. Insert the key bit in the lock cylinder.
3. Turn the emergency key right to lock the vehicle *fig. 47*.
4. Turn the emergency key left to unlock the vehicle.
5. Pull firmly on the driver door handle to open the door.
6. Replace the cap.

Locking the front passenger door and rear doors in an emergency

Please read the introductory information and heed the Warnings and Notice \Rightarrow and Introduction.



A22-0079

Fig. 48 In the front edge of the rear right-hand door: vehicle emergency lock for using the emergency key (general example).

The front passenger door and the rear doors can each be locked manually.

1. Open the door.
2. Remove the rubber seal in the front of the door.
3. Insert the emergency key in the vertical slot and turn it inwards *fig. 48*.
4. Reattach the rubber seal.
5. Check that the door is locked.
6. Have the vehicle checked immediately by a suitably qualified professional. Volkswagen recommends contacting an authorized Volkswagen dealer or authorized Volkswagen Service Facility.

If a door is locked manually, it will unlock again when the vehicle is unlocked or if that door is opened from the inside.

Doors can be unlocked and opened from the inside by pulling the door handle.

Electrical childproof lock

📖 Please read the introductory information and heed the Warnings and Notice ⇒ ⚠️ and ⓘ Introduction.



Fig. 49 In the driver door: Control for the electric child safety lock.

ⓘ Control for the child safety lock.

The electrical childproof lock stops the doors and the electric windows being opened.

Switching the electric childproof lock on or off

- *Switching on:* press the control [fig. 49](#)
- *Switching off:* press the control again.

If the child safety lock is active, the yellow indicator light  in the control will come on [fig. 49](#).

Error message in the Infotainment system or instrument cluster display

If the electric child safety lock is activated and a rear door is opened at the same time, the electric child safety lock cannot be switched on or off at this door.

An error message is displayed in the Infotainment system or the instrument cluster display.

1. Press the button for the electric child safety lock again to synchronize the condition of the rear doors.
2. If the error message does not disappear, contact a suitably qualified workshop and have the child safety lock checked. Volkswagen recommends contacting an authorized Volkswagen dealer or authorized Volkswagen Service Facility.

⚠️ WARNING

When the electric childproof lock is switched on, that particular door cannot be opened from the inside. This can result in people locking themselves inside the vehicle. In an emergency, they may not be able to exit the vehicle without assistance or help themselves.

- Never leave children or people requiring assistance unattended in the vehicle when the doors are locked.

⚠️ WARNING

If you leave children, people requiring assistance or animals unattended in the vehicle, they may be subjected to very high or low temperatures. There is a risk of serious or fatal injuries.

- Never leave children, people requiring assistance or animals unattended in the vehicle.

Troubleshooting

📖 Please read the introductory information and heed the Warnings and Notice ⇒ ⚠️ and ⓘ Introduction.

If the indicator light does not turn off

The red LED in the vehicle door flashes briefly and then stays on.

There is a malfunction in the locking system.

1. Contact a suitably qualified professional. Volkswagen recommends contacting an authorized Volkswagen dealer or authorized Volkswagen Service Facility.

If the turn signals are not flashing

The turn signals are not blinking as confirmation when locking the vehicle:

1. Check whether all of the doors and the trunk lid and engine hood are closed.
2. Close any doors and trunk lid or engine hood that are not closed.

If the vehicle is locking automatically

The vehicle will lock again automatically after approximately 45 seconds if one of the following conditions apply:

- The vehicle was unlocked, but not opened
- The ignition was not switched on
- The trunk lid was not opened.
- The vehicle was unlocked using the lock cylinder
- The vehicle was locked via the control panel in the vehicle interior.

Locking with a second vehicle key

The key inside the vehicle will be blocked from activating the vehicle's drive system if the vehicle is locked from the outside with a different vehicle key.

1. To enable the vehicle key inside the vehicle so that it can be used to activate the vehicle's drive system as usual, press the  button on the vehicle key inside the vehicle ⇒ *Activating the vehicle's drive system*.

Locking the vehicle after an airbag deploys

The entire vehicle unlocks when an airbag deploys in a collision. Depending on the severity of the damage, it may be possible to lock the vehicle as follows after the collision:

1. Switch the ignition off.
2. Open the driver door and shut it again.
3. Lock the vehicle.

NOTICE

Strong streams of water or vapor could activate the sensors in the door handles if a valid vehicle key is located near the vehicle. This may cause the windows to open and moisture may enter the vehicle interior. This could lead to damage to the vehicle interior.

- Never direct the jet of a high pressure cleaner or a steam jet directly towards the sensors in the door handles.

 It may not be possible to unlock or lock the vehicle using Keyless Access if the 12 V vehicle battery or button cell battery in the vehicle is weak or drained. The vehicle can be manually unlocked or locked.

 If there is no valid remote control vehicle key in the vehicle or the key is not detected, a corresponding message appears in the ID. cockpit. This can occur if another signal interferes with the remote control vehicle key or if the remote control vehicle key is covered by an object, such as a metal case.

Trunk lid

Introduction

The trunk lid is unlocked and locked together with the doors.

On vehicles with Keyless Access, the trunk lid is automatically unlocked when opening ⇒ *"Keyless Access" with push-button start*.

If individual door opening or the opening of one side of doors is activated in the Infotainment system settings for opening and closing, you must press the  button on the remote control vehicle key twice to unlock the trunk lid.

On vehicles with Keyless Access you must press the sensor on the inside of the driver's or front passenger's door handle twice to do this.

WARNING

Uncontrolled or unintentional release: opening and closing the trunk lid can cause accidents and serious injuries.

- Do not open or close the trunk lid if anyone is in the way.
- Always keep the trunk lid closed while driving.
- Close and lock the trunk lid and all doors when the vehicle is not in use.
- Check that, when closed, the trunk lid is flush with the areas of the vehicle body around it.

WARNING

Depending on the season, the temperature inside the vehicle could become very high or low, which can lead to serious injuries, illness or death, especially for very young children.

- Make sure that no one remains in the vehicle.
- Never let children play in or on the vehicle unattended, especially when the trunk lid is open. Children could enter the luggage compartment, close the lid, and then lock themselves in.

WARNING

The vehicle may not always detect when the trunk lid is not latched if a cargo rack that is carrying cargo is mounted on the trunk lid. If the trunk lid is not latched, it may open suddenly while driving. This may cause serious injuries.

- Check that, when closed, the trunk lid is flush with the areas of the vehicle body around it.

WARNING

If there is a heavy load of snow or cargo on the trunk lid, the additional weight may cause the lid to lower, which can result in serious injuries.

- Never open the trunk lid if there is a heavy load of snow or cargo such as a cargo rack on it.
- Remove the snow or cargo before opening the trunk lid.
- If necessary, support the trunk lid or remove the cargo and/or snow before opening the trunk lid.

WARNING

Closing the trunk lid incorrectly may lead to the rear window shattering and cause serious injuries.

- Do not push the trunk lid closed with your hand on the rear window.

NOTICE

Using the opening mechanism incorrectly may damage the component and could prevent the trunk lid from closing.

- Never attach or secure cargo on the opening mechanism.

NOTICE

Using the rear window wiper incorrectly may damage the component and result in it breaking off.

- Never attach or secure cargo to the rear window wiper.

NOTICE

Using the rear spoiler incorrectly may damage the component and result in it breaking off.

- Never attach or secure cargo to the rear spoiler.

Opening and closing the trunk lid

 Please read the introductory information and heed the Warnings and Notice  and  Introduction.

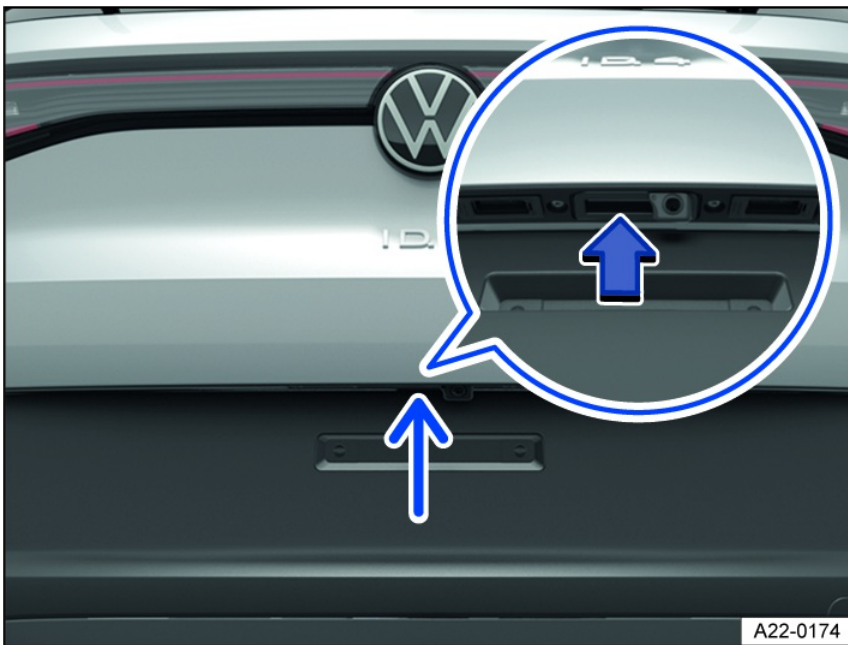



Fig. 50 In the trunk lid: button to open the trunk lid.



Fig. 51 In the open trunk lid: handle for closing the trunk lid (general example).

Opening the trunk lid

1. To unlock the trunk lid, press the  or  button on the vehicle key.
2. Raise the trunk lid using the button *fig. 50*.

Closing the trunk lid

1. Pull the trunk lid downward firmly using the handle in the interior trim panel until it latches shut in the lock *fig. 51*, ⇒ .

An image in the instrument cluster display indicates if the trunk lid has not opened or closed correctly.

The trunk lid locks automatically while driving.



WARNING

Closing the trunk lid incorrectly or carelessly may lead to serious injuries.

- When opening the trunk lid, take care to pull it all the way up.
- When closing the trunk lid, make sure your hands are not within the closing range of the lid.

 If the trunk lid is not opened within several minutes after unlocking, it will lock again automatically.

Power opening and closing the trunk lid

 Please read the introductory information and heed the Warnings and Notice ⇒  and  Introduction.



A21-0132

Fig. 52 In the driver's door: unlock button for the trunk lid.

- ① Release button.



A22-0176

Fig. 53 In the open trunk lid: Button for power closing the trunk lid (general example).

Power opening the trunk lid

1. Briefly press and hold the  or  button on the remote control vehicle key.

Or: pull the  button in the driver door upward *fig. 52*.

Or: press the button to open the trunk lid ⇒ *Opening and closing the trunk lid*.

The trunk lid will open automatically.

Power closing the trunk lid

1. Press the button in the trunk lid when it is open *fig. 53*.

Or: pull the  button in the driver door upward when the ignition is switched on until the trunk lid is closed *fig. 52*.

Or: *On vehicles with Keyless Access with push-button start:* briefly press and hold the  button on the vehicle key. The vehicle key must be nearby to use this feature.

Or: Begin closing the trunk lid by hand until it closes by itself.

The trunk lid is closed.

Interrupting the opening or closing process

1. Press the  or  button on the vehicle key while the lid is opening or closing.

Or: press the button on the trunk lid while the lid is opening or closing *fig. 53*.

The trunk lid can now be moved by hand. It is necessary to use more force when doing this.

Pressing the  button again moves the trunk lid back to the original position.

Chimes

When the trunk lid is opened or closed from inside the vehicle or using the vehicle key, chimes will sound.

Changing and saving the opening angle

If the space behind or above the vehicle is not large enough to allow the trunk lid to open completely, you can change how far the trunk lid opens.

1. Interrupt the opening process at the preferred open position.

The trunk lid must be at least half open.

2. Press and hold the  button in the trunk lid until the emergency flashers start flashing *fig. 53*.

The adjusted opening angle is saved.

There will be an audible signal and the emergency flashers will flash to indicate that the setting was saved.

WARNING

Closing the trunk lid incorrectly or carelessly may lead to serious injuries.

- When closing the trunk lid, make sure your hands are not within the closing range of the lid.

NOTICE

If you open or close the trunk lid when there is not enough space, this may cause damage.

- Before opening or closing the trunk lid, check whether there is enough room, e.g. in garages.

Trunk lid with Easy Open motion sensor

 Please read the introductory information and heed the Warnings and Notice \Rightarrow  and  Introduction.

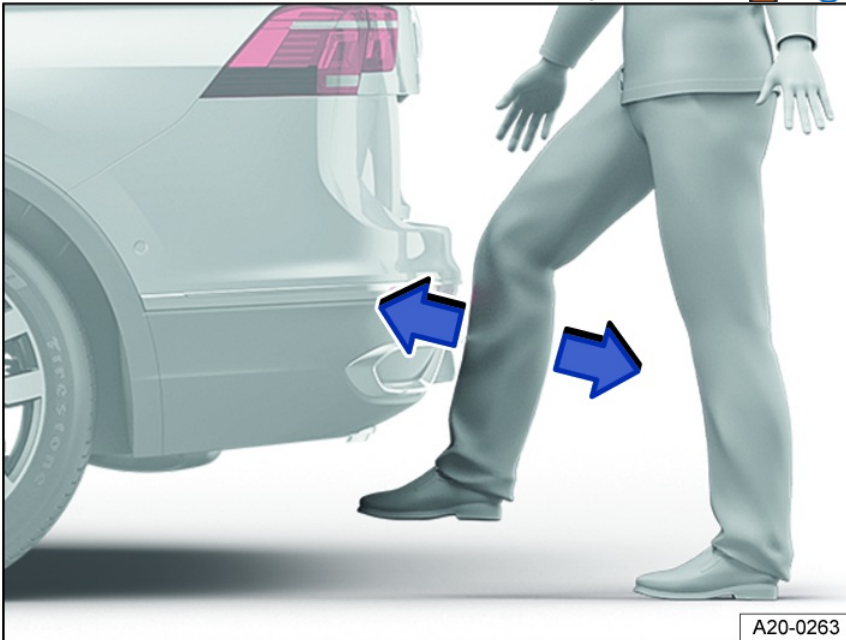

Fig. 54 General example of the sensor-controlled luggage compartment opener (Easy Open).

If a valid vehicle key is located near the trunk lid, the trunk lid can be unlocked and opened with foot motion.

1. Position your foot behind the middle of the bumper.
2. Quickly swing the lower part of your leg close to the bumper *fig. 54*.
3. Quickly remove the lower part of your leg once more from the bumper.

Visual feedback is given via the turn signals. The trunk lid will open.

Activating or deactivating the Easy Open function

The Easy Open function can be activated and deactivated in the Infotainment system:

1. Select the Vehicle menu.
2. Swipe to the side and activate or deactivate Easy Open.

Or:

1. Swipe to the side and select the Central locking menu item.
2. Scroll down the list and activate or deactivate Easy Open.

If Easy Open is activated, Easy Close is also active \Rightarrow *Automatic trunk lid closing Easy Close*.

The Easy Open function is only available when Keyless Access is activated \Rightarrow *"Keyless Access" with push-button start*.

The sensor-controlled luggage compartment opener (Easy Open) function may be triggered inadvertently in the following situations:

- During charging operations in which a charging cable is brought to the lower rear area of the vehicle.
- If there is a sweeping motion under the rear bumper.
- If a strong stream of water or steam passes.
- During maintenance and repair work in the area of the rear bumper.
- If there are moving gates in the vicinity of the bumper.

⚠ CAUTION

If a valid vehicle key is detected near the trunk lid, the sensor-controlled luggage compartment opener (Easy Open) function may trigger unintentionally and open the trunk lid in some cases. If the trunk lid opens unintentionally, it may cause injuries to people and/or damage to objects within the trunk lid's range of motion.

- After parking the vehicle, switch off the sensor-controlled luggage compartment opener (Easy Open) function via the Infotainment system if you park close to obstacles, e.g. street lamps, posts and garage doors, or if you park in an underground car park with a low ceiling.
- Always make sure that no valid vehicle keys are left unattended near the trunk lid.
- Always turn off the sensor-controlled luggage compartment opener (Easy Open) function via the Infotainment system before any and all maintenance and repair work is performed on the vehicle.
- Always turn off the sensor-controlled luggage compartment opener (Easy Open) function via the Infotainment system before washing the vehicle.
- Always switch off the sensor-controlled luggage compartment opener (Easy Open) function via the Infotainment system before mounting a bicycle rack or hitching a trailer ⇒ [Introduction](#).

Automatic trunk lid closing Easy Close

📖 Please read the introductory information and heed the Warnings and Notice ⇒ ⚠ and ⚠ Introduction.

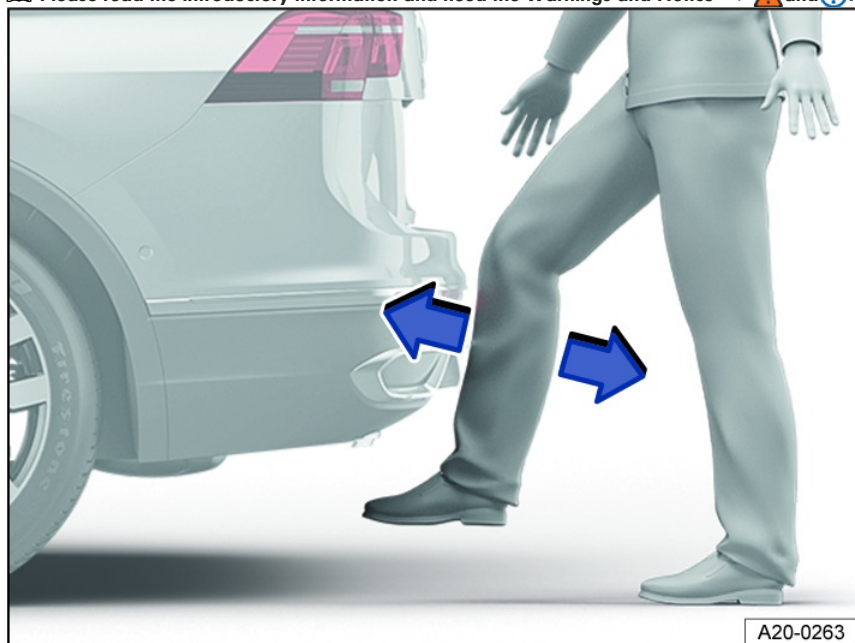

Fig. 55 General example of the trunk lid with sensor-controlled closing (Easy Close).

You can only activate the Easy Close function if a valid remote control vehicle key is detected near the trunk lid.

1. Position your foot behind the middle of the bumper.
2. Quickly swing the lower part of your leg close to the bumper [fig. 55](#).
3. Quickly remove the lower part of your leg once more from the bumper.

Easy Close is activated for approx. 20 seconds. A chime will confirm successful activation.

The trunk lid is closed as soon as all valid vehicle keys are removed from the area near the trunk lid.

The trunk lid will lock automatically after it closes if the vehicle was previously locked and there is not a valid vehicle key inside the vehicle.

Easy Close permits locking a maximum of one vehicle key in the luggage compartment.

The locking procedure is interrupted as soon as a vehicle key returns nearby. The trunk lid re-opens.

Activating or deactivating the Easy Close function

The function Easy Close can be activated or deactivated together with the sensor-controlled luggage compartment opener (Easy Open) function in the Vehicle menu in the Infotainment system ⇒ [Trunk lid with Easy Open motion sensor](#).

The Easy Close function is only available when Keyless Access is activated ⇒ *"Keyless Access" with push-button start*.

The Easy Close function may be triggered inadvertently in the following situations:

- During charging operations in which a charging cable is brought to the lower rear area of the vehicle.
- If there is a sweeping motion under the rear bumper.
- If a strong stream of water or steam passes.
- During maintenance and repair work in the area of the rear bumper.
- If there are moving gates in the vicinity of the bumper.

CAUTION



If a valid vehicle key is detected near the trunk lid, the Easy Close function may trigger unintentionally and close the trunk lid in some cases. If the trunk lid closes unintentionally, it may cause injuries to people and/or damage to objects within the trunk lid's range of motion.

- After parking the vehicle, switch off the Easy Close function via the Infotainment system if you park close to obstacles, e.g. street lamps, posts and garage doors, or if you park in an underground car park with a low ceiling.
- Always make sure that no valid vehicle keys are left unattended near the trunk lid.
- Always make sure that there are no people in the swivel range of the trunk lid.
- Do not hold on to anything in the path of the trunk lid.
- Always turn off the Easy Close function via the Infotainment system before any and all maintenance and repair work is performed on the vehicle.
- Always switch off the Easy Close function via the Infotainment system before washing the vehicle.
- Always switch off the Easy Close function via the Infotainment system before mounting a bicycle rack or hitching a trailer ⇒  [Introduction](#).

 If another trunk lid function is activated while closing the trunk lid or objects are detected in the area of the trunk lid, the closing process is automatically interrupted.

 If the vehicle is locked and the Easy Close function is started, the trunk lid will lock automatically once it is closed. If the vehicle is completely unlocked and the Easy Close function is started, the trunk lid will not lock automatically once it is closed.

Troubleshooting

 Please read the introductory information and heed the Warnings and Notice ⇒  and  [Introduction](#).

If the trunk lid will not open or close

- Check if the trunk lid is being blocked by an object.

The trunk lid can be moved by hand. It is necessary to use more force when doing this.

- If the trunk lid is operated too frequently within a short period of time, then the lid motor will automatically switch off to reduce the risk of overheating. Until the motor has cooled down, the trunk lid can be opened and closed by hand using extra force.
- When in trailer mode, the power trunk lid can only be opened and closed at the trunk lid.
- If the 12-volt vehicle battery or fuse is disconnected or malfunctioning, the trunk lid must be closed by hand.

If all turn signals flash four times

The vehicle key that was last used is still in the vehicle.

1. Remove the key and lock the vehicle.

If the trunk lid is difficult to move

The mechanism for opening the trunk lid may not always work automatically when the outside temperatures are around the freezing point.

1. Guide the trunk lid farther upward by hand.

The Easy Open sensor function is not working

- Easy Open only works when the ignition is switched off.
- Clean the sensors in the rear bumper.
- The trailer hitch is extended.
- The vehicle was retrofitted with a trailer hitch.
- Easy Open may be deactivated in heavy precipitation to reduce the risk of false activation.

Windows

Openina and closina the windows

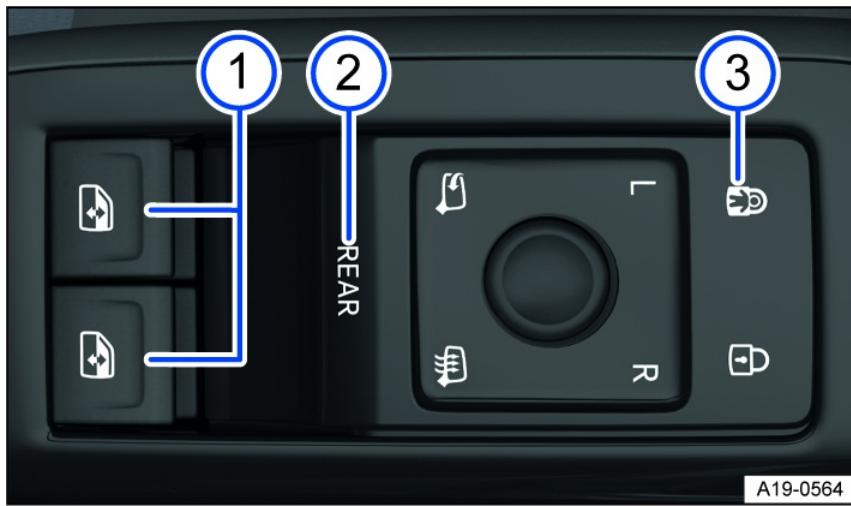



Fig. 56 In the driver door: Buttons for the front and rear power windows.

- ① Buttons for the power windows.
- ② Control **REAR** for activating the rear power windows and convenience opening and closing.
- ③ Control for deactivating the power window buttons in the rear doors and for switching on the electric child safety lock.

As standard, the  *fig. 56* ① buttons can be used to operate the power windows in the front doors.

The windows can still be opened or closed using the switches in the doors for a brief period after the ignition has been switched off, as long as the driver's or front passenger door is not opened.

Opening the windows

1. Press the  button.

Closing the windows

1. Pull the  switch.

Deactivating the power window buttons in the rear doors

1. Press the control panel  *fig. 56* ③.

At the same time, the electric child safety lock is switched on and the yellow indicator light in the control comes on.

Using the Control **REAR**

1. Briefly press the control **REAR** *fig. 56* ② to activate operation of the power windows in the rear doors.

The function light in the control comes on at the same time.

2. Briefly press the control **REAR** *fig. 56* ② again to activate operation of the power windows in the front doors.

If, after operation is activated, the power windows in the rear doors are not used, operation of the power windows in the front doors is reactivated after around ten seconds.

One-touch opening and closing function

The one-touch opening and closing function allows the windows to be completely opened or closed. To use this feature, do not hold the window switch up or down.

- To start the one-touch closing function, pull the window switch upward briefly to the second level.
- To start the one-touch opening function, press the window switch downward briefly to the second level.
- To stop the one-touch opening or closing function, pull or press the switch for that window again.

Convenience opening and closing

1. Press and hold the control **REAR** to activate convenience opening and closing of the power windows in all doors.

If the function is activated, the function light in the control blinks. Both of the buttons  can now simultaneously open or close all four windows.

2. Briefly press and hold the control **REAR** again to deactivate the function.

If, after activation of the convenience opening and closing, the power windows are not used, the operation of the power windows in the front doors is reactivated after around ten seconds.

Opening

The windows can be opened from outside the vehicle using the vehicle key when the ignition is switched off.

1. Press and hold the unlock button on the vehicle key.
2. To stop the function, release the unlock button.

Closing

1. *On vehicles with Keyless Access with push-button start:* press the sensor surface or locking button on the door handle for a few seconds, until the windows are closed ⇒ *"Keyless Access" with push-button start*. The vehicle key must be nearby to use this feature.

When all of the windows and the power sunroof are closed, the turn signals will blink once as a confirmation.

2. To stop the function, remove your finger from the sensor or switch.

You can select the convenience opening settings in the Vehicle settings menu in the Infotainment system.

WARNING

Careless or unintended use of the power windows can cause serious injuries.

- Do not open or close the power windows if anyone is in the way.
- Always take all vehicle keys with you when leaving the vehicle.
- Note that the windows can still be opened or closed using the door buttons for a brief period after the ignition has been switched off, as long as the driver's or front passenger door is not opened.
- When driving with children seated on the rear bench seat, always disable the rear power windows so that the windows cannot be opened or closed.

WARNING

If the vehicle is locked, the windows can no longer be opened and will prevent people from escaping from the vehicle interior. In an emergency, this could cause serious or fatal injuries.

- Never leave children or people requiring assistance unattended in the vehicle when the vehicle is locked.

NOTICE

If the windows are open, precipitation can enter the vehicle and soak the interior equipment, which could restrict the function of the controls or damage them.

- Close all windows if there is precipitation.

 **If the power windows are malfunctioning, the one-touch opening and closing function and the pinch protection may not function correctly. Contact a suitably qualified professional. Volkswagen recommends contacting an authorized Volkswagen dealer or authorized Volkswagen Service Facility.**

 **Convenience opening and closing only functions if the one-touch opening and closing function is activated for all the power windows.**

Power window pinch protection

The power window pinch protection can reduce the risk of being pinched and injured when the windows are closing.

If the window cannot close due to resistance or an obstacle, then the window will reopen immediately ⇒ .

1. Check why the window did not close.
2. Try again to close the window.

If the window will not close again, then the pinch protection will be disabled for several seconds.

If the window still cannot close, then the window will stop at the place where it meets resistance. If you press the switch again within several seconds, the window will close without pinch protection ⇒ .

Closing windows without pinch protection

1. Try to close the windows again within a few seconds by holding the switch. This will disable the pinch protection.

If the closing process takes longer than several seconds, then pinch protection will be enabled again. If there is resistance to the window moving or an obstacle is blocking the window, then the window will reopen automatically.

2. If the window still cannot close, then contact a suitably qualified professional. Volkswagen recommends contacting an authorized Volkswagen dealer or authorized Volkswagen Service Facility.

WARNING

Closing the window when pinch protection is disabled can result in serious injuries.

- Always be careful when closing the windows.
- Do not close windows if anyone is in the way.
- Note that the pinch protection does not prevent fingers or body parts from being trapped against the window frame.

 Pinch protection also occurs when using the convenience closing function with the vehicle key.

Troubleshooting

One-touch up/down feature

If the 12 V vehicle battery is disconnected or drained when the windows are not completely closed, then the one-touch up/down feature will not work. It must be reprogrammed using the following steps:

1. Switch the ignition on.
2. Close all windows and doors.
3. Pull the switch for the desired window and hold it in that position for several seconds.
4. Release the switch, then pull it upward again and hold it.

The one-touch up and down features will then be fully functional.

The automatic power windows can be reprogrammed individually, or multiple windows can be reprogrammed at the same time.

Controls are responding differently than expected

Moisture, dirt and grease may limit the functioning of the controls.

1. Always keep the control panels clean and dry.

Steering wheel

Adjusting the steering wheel position

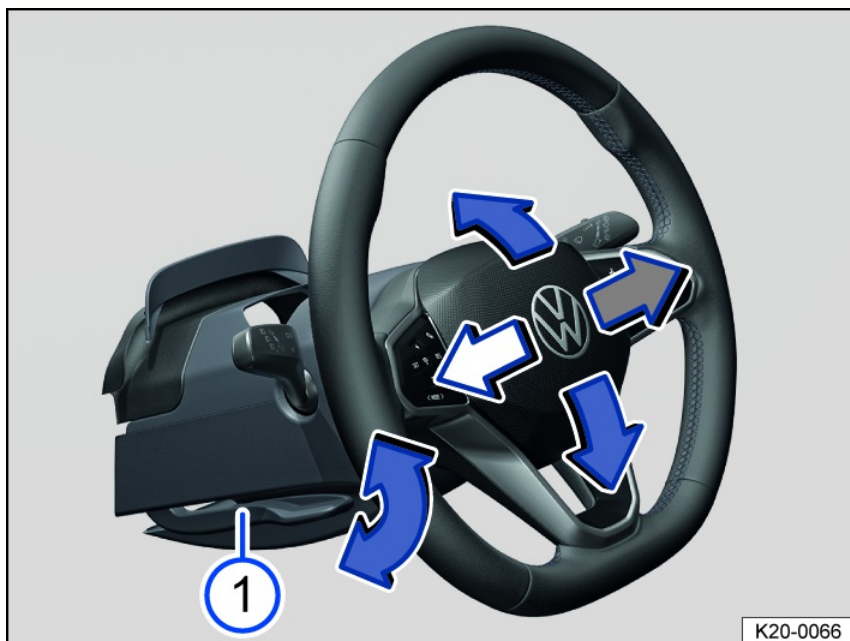



Fig. 57 Under the steering wheel in the steering column trim panel: lever to adjust the steering wheel position manually (general example).



Fig. 58 On the steering wheel: nine o'clock and three o'clock position.

Only adjust the steering wheel before driving or while the vehicle is stationary ⇒ ⚠.

1. Tilt the lever [fig. 57](#) downward.
2. Adjust the steering wheel so that it can be firmly held at the outer edge with both hands at the nine o'clock and three o'clock position [fig. 58](#).

3. Press the lever all the way up until it locks flush with the steering column trim panel ⇒ .

 **WARNING**

Incorrect use of the steering wheel adjuster and an incorrect steering wheel adjustment could cause serious or fatal injuries.

- Always push the lever *fig. 57*  upward into its locked position after adjusting so that you do not change the steering wheel position unintentionally while driving.
- Never adjust the steering wheel while driving. If you find the steering wheel must be adjusted while driving, stop the vehicle safely and adjust the steering wheel correctly.
- The steering wheel must always face toward the chest and never toward the face. Otherwise, the protective function of the driver's front airbag may be limited in the event of an accident.
- To reduce the risk of injuries if the driver's front airbag deploys, always hold the outer edge of the steering wheel firmly with both hands in the nine o'clock and three o'clock position *fig. 58*.
- Never hold the steering wheel in the twelve o'clock position or in any other way, such as holding the center of the steering wheel. Otherwise, the arms, hands, and head could be seriously injured if the driver's front airbag deploys.

Seats and head restraints

Front seats

Introduction

The following information describes the various options for adjusting the front seats. Always make sure the seats are adjusted to the correct position ⇒  [Introduction](#).

WARNING

Driving in an incorrect seating position due to seats being adjusted incorrectly may cause serious injuries.

- Adjust the front seats according to the correct seating position each time before driving and make sure all passengers have their safety belts fastened correctly.
- Move the front passenger seat all the way back.

WARNING

Adjusting the seats incorrectly can cause accidents and serious injuries.

- Only adjust the seats when the vehicle is stationary. Otherwise, the position of the seats could change unexpectedly while driving and you could lose control of the vehicle. You could also put yourself in an incorrect seating position.
- Only adjust the height, angle, and forward/back position of the front seats when there is no one within the seat's range of movement.
- Do not restrict the movement of the seats by placing objects within their range of movement.
- The adjusting and locking areas of the seats must not be dirty.

WARNING

Using seat covers or protective covers incorrectly can result in unintentionally operating the seat adjusters, and the front seats could move unexpectedly while driving. This could cause you to lose control of the vehicle. This can cause accidents and injuries. The electrical components in the front seats could also be damaged.

- Never install or secure seat covers and protective covers on the electrical controls.
- Only use seat covers or protective covers that are specifically approved for use in your vehicle.

WARNING

Lighters in the vehicle can become damaged or ignite unintentionally. This can cause severe burns and vehicle damage.

- Before adjusting any seat, always make sure that there are no cigarette lighters near the moving parts of the seat.

NOTICE

Objects with sharp edges can damage the seats.

- Never touch the seats with sharp-edged objects. Sharp-edged objects, such as zippers, rivets on clothing, or belts, can cause surface damage. Open hook and loop fasteners can also cause damage.

Manually adjusting front seats

 Please read the introductory information and heed the Warnings and Notice ⇒  and  [Introduction](#).

The information that follows describes all possible controls. Depending on the seat version, the number of controls may vary.

The controls on the front passenger seat are a mirror image of those for the driver seat.

A seat may have both manual and power controls.



Fig. 59 On the driver seat: Controls.

- ① Pull the lever to slide the front seat forward or backward. The front seat must lock into place after the lever is released.
- ② To adjust the backrest, pull the lever, lean forward or backward and release the lever again.
- ③ If necessary, move the lever upward or downward multiple times to adjust the height of the seat.

Adjusting power front seats

📖 Please read the introductory information and heed the Warnings and Notice ⇒ ⚠️ and ⓘ Introduction.

The electric controls differ depending on the country and vehicle equipment and may vary according to the seat design.

The controls on the front passenger seat are a mirror image of those for the driver seat.

A seat may have both manual and power controls.

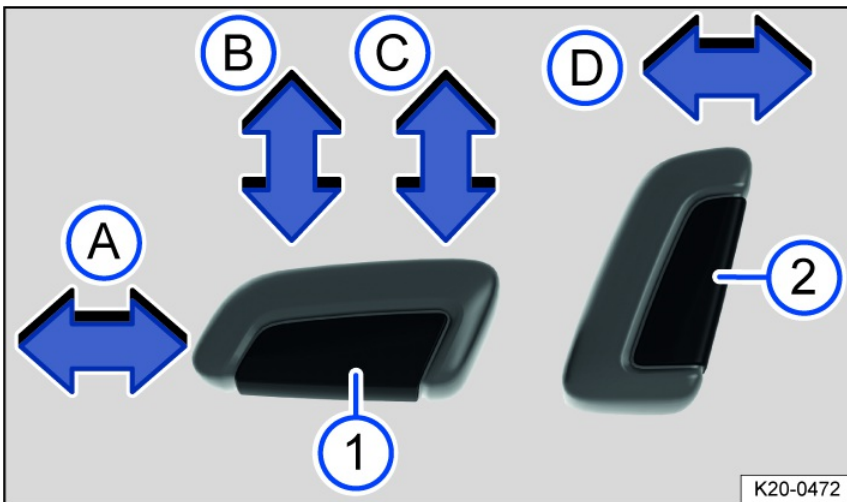

Fig. 60 Switch on the driver seat: Adjusting the front seat forward/back, the height and angle of the seat surface, and the front seat backrest.

Press the switch in the direction of the arrow:

- Ⓐ Slide the seat forward or backward.
- Ⓑ Adjust the angle of the seat surface.
- Ⓒ Adjust the height of the seat.
- Ⓓ Adjust the angle of the backrest.

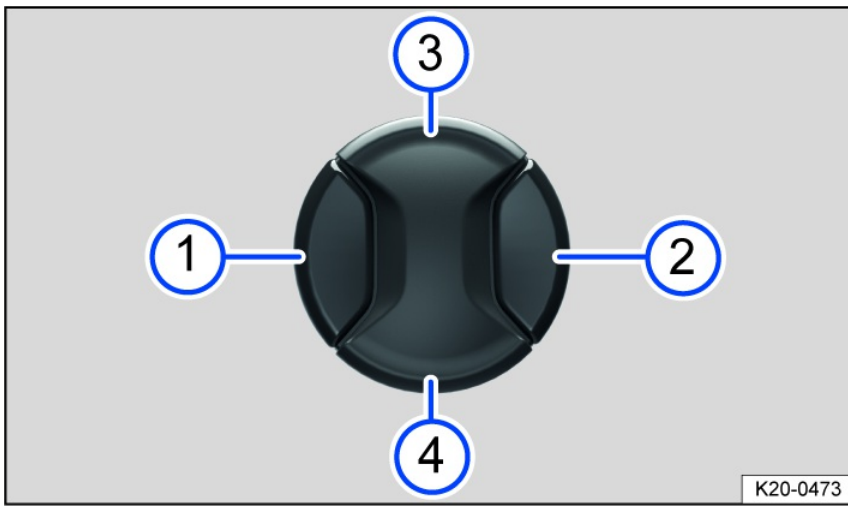

Fig. 61 Switch on the driver seat: Adjusting the lumbar support.

Press the switch in the direction you would like the lumbar support to move.

- ① Move the curvature of the lumbar support forward.
- ② Move the curvature of the lumbar support backward.
- ③ Raise the curvature of the lumbar support.
- ④ Move the curvature of the lumbar support down.

⚠ WARNING

Careless or unintended use of the power front seats can cause serious injuries.

- The power front seats can also be adjusted when the ignition is switched off. Never leave children or people requiring assistance in the vehicle.
- In case of an emergency, interrupt the power adjustment by pressing another switch.

ⓘ NOTICE

Incorrect usage may damage the electric components in the front seats.

- Do not kneel on the front seats and do not otherwise concentrate pressure on specific points of the seat cushion and backrest.

ⓘ If the 12 V vehicle battery charge level is too low, the seat may not be able to be adjusted with the power controls.

ⓘ Seat adjustments will be canceled while the vehicle's drive system is being activated.

Rear seats

📖 Introduction

The following information describes the various options for adjusting the rear seats. Always make sure the seats are adjusted to the correct position → *Correct seating position*.

⚠ WARNING

Incorrectly positioned rear seats increase the risk of serious injuries if an accident occurs.

- Before every journey, ensure that the rear seats are positioned so that all passengers are sitting upright and have their safety belts on correctly.
- Only adjust the rear seats when there is no one within the range of movement of the seats.

⚠ WARNING

If you adjust the rear seats while driving, you will adopt the wrong sitting position. In addition, the rear seats may move unexpectedly during the journey. This will increase the risk of serious injuries if an accident occurs.

- Only adjust the rear seats when the vehicle is stationary.

⚠ WARNING

Lighters in the vehicle can become damaged or ignite unintentionally. This can cause severe burns and vehicle damage.

- Before adjusting any seat, always make sure that there are no cigarette lighters near the moving parts of the seat.

⚠ WARNING

Incorrect use of the rear center armrest may cause serious injuries.

- The rear center armrest must always be folded up during journeys.
- If the center armrest is folded down, the center rear bench seat must never be used by either adults or children.
- Never allow an adult or child to ride on the center armrest.

ⓘ NOTICE

Objects in the luggage compartment may get into the space between the seat and the luggage compartment floor when the rear seat is adjusted. This may cause damage.

- Remove all objects located between the seat and luggage compartment floor before you move the rear seat.

ⓘ NOTICE

Objects with sharp edges can damage the seats.

- Never touch the seats with sharp-edged objects. Sharp-edged objects, such as zippers, rivets on clothing, or belts, can cause surface damage. Open hook and loop fasteners can also cause damage.

Folding the rear bench seat backrest forward or backward

📖 Please read the introductory information and heed the Warnings and Notice ⇒ ⚠ and ⓘ Introduction.

The seat backrest is divided. Each part of the rear seat backrest can be folded forward individually to enlarge the luggage compartment.

Folding the rear seat backrest forward and down with the release button



Fig. 62 In the rear seat backrest: release button.

1. Move the head restraints all the way down.
2. Pull the release button *fig. 62* forward while folding the rear seat backrest forward and down.

The corresponding backrest part of the rear seat backrest is released when the red marking *fig. 62* can be seen.

Folding the rear seat backrest up and back

1. Fold the rear seat backrest to the back and push firmly into the catch until it securely engages ⇒ ⚠.

The red marking *fig. 62* must no longer be visible.

⚠ WARNING

Folding and unfolding the rear seat backrest in an uncontrolled or careless manner may cause severe injury.

- Always take care that no people or animals are in the way of the rear seat backrest when folding it forward and down.
- Never fold the rear seat backrest forward or back while driving.
- Make sure the safety belt is not pinched or damaged when folding the rear seat backrest back.
- Keep hands, fingers, feet and other body parts away from the rear seat backrest when folding forward or back.
- Each rear seat backrest must always be securely engaged to ensure that the safety belts in the rear seats can provide the maximum protection. Take extra care especially with the middle seat in the rear bench seat. If a seat on the rear bench is used without the rear seat backrest being engaged, the vehicle occupant will move forward with the rear seat backrest in the event of sudden braking and driving maneuvers or a collision.
- A red marking *fig. 62* indicates that the rear seat backrest is not engaged. Always check that the red marker is not visible when the rear seat backrest is in the upright position.
- Never allow people to sit in a rear seat if that rear seat backrest is folded forward or is not engaged.

NOTICE

Folding and unfolding the rear seat backrest in an uncontrolled or careless manner may cause damage to the vehicle or other objects.

- Before folding the rear seat backrest forward, always adjust the front seats so that the head restraint or padding on the rear seat backrest does not press against the front seats.
- Before folding the rear seat backrest forward, always take care that there are no objects in its path.

Head restraints

Introduction

The information that follows describes how the head restraints can be adjusted and removed. Always make sure the seats are adjusted to the correct position ⇒ *Correct seating position*.

All seats are equipped with head restraints. The head restraints are specially approved for the relevant seat and should not be installed in another seat in the vehicle.

The center rear head restraint (depending on the vehicle equipment) is only intended for the center seat on the rear bench seat. Therefore do not install this head restraint in any other position.

There are notches in the head restraint supports so that they can be locked in different positions. Only head restraints which are correctly mounted can lock into the notches within the adjustable range. To prevent the head restraints from being removed unintentionally after mounting, there are stops at the top and bottom of the adjustable range.

Correct head restraint adjustment

Adjust the head restraint so that the upper edge of the head restraint is in line with the upper portion of the head as much as possible, but not lower than eye level. Position the back of the head as close as possible to the head restraint.

Head restraint adjustment for shorter persons

Slide the head restraint all the way down, even if the head is then below the upper edge of the head restraint. When the head restraint is in the lowest position, there may be a small gap between the head restraint and the backrest.

Head restraint adjustment for taller persons

Move the head restraint up all the way.

WARNING

Driving with head restraint that have been removed or adjusted incorrectly increases the risk of serious or fatal injuries in the event of an accident or sudden driving and braking maneuvers.

- If a person is sitting in a seat, always drive with the head restraint correctly installed and adjusted on that seat.
- If a person is sitting in a seat, adjust the head restraint according to their height.
- Never adjust the head restraint while driving.

NOTICE

Removing and fitting the head restraints incorrectly may cause damage.

- When removing and installing the head restraint, make sure the head restraint does not hit the headliner, the front seat backrest, or other vehicle components.

Adjusting the head restraints

📖 Please read the introductory information and heed the Warnings and Notice ⇒ ⚠️ and ⓘ Introduction.

Adjusting the height of the front head restraint



Fig. 63 Adjusting the front head restraint (general example).

1. Push the head restraint upward in the direction of the arrow or slide it downward while pressing the button *fig. 63*.

The head restraint must lock securely into the top position or into an intermediate position. In the bottom position, where the guide rod is slid completely into the guide rail, the head restraint does not lock.

Adjusting the height of the rear head restraint

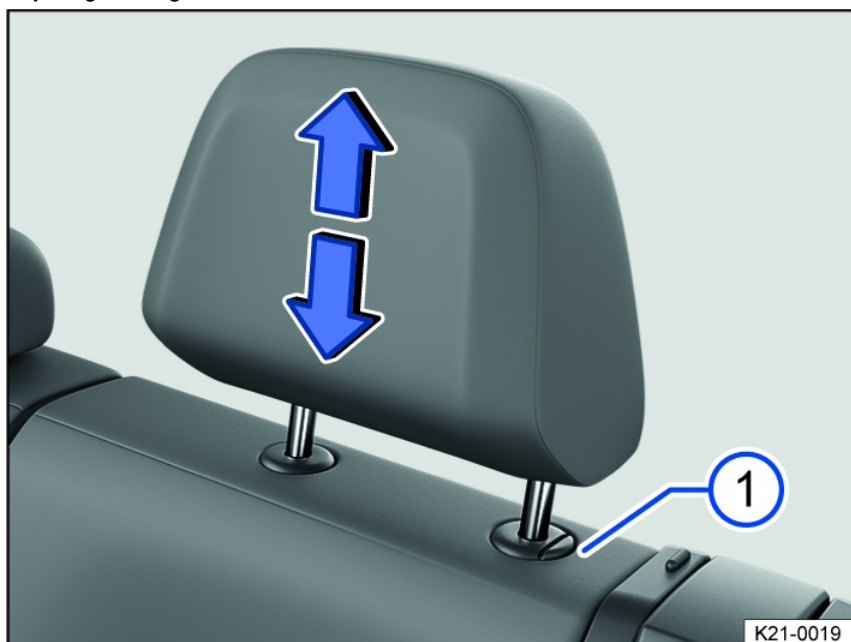

Fig. 64 Adjusting the rear head restraint (general example).

1. If necessary, slide the head restraint upward or downward in the direction of the arrow and when pressing the *fig. 64* button.

The head restraint must lock securely into place.

Removing and installing the head restraints

📖 Please read the introductory information and heed the Warnings and Notice ⇒ ⚠️ and ⓘ Introduction.

Removing the front head restraints

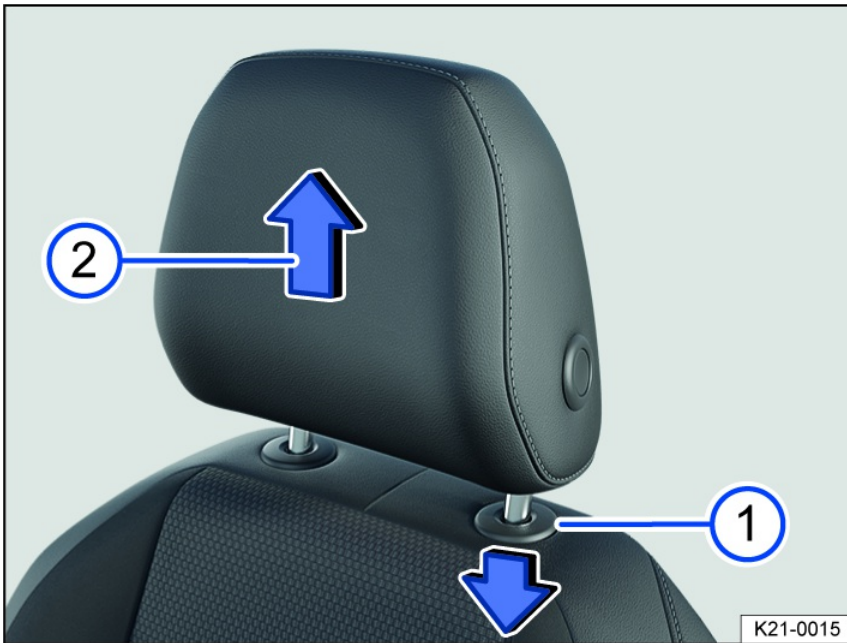

Fig. 65 Removing the front head restraint (general example).

1. Lower the head restraint if necessary.
2. To unlock, press down the ring around the guide rod of the head restraint *fig. 65*.
3. Pull out the head restraint in the direction of the arrow *fig. 65*.

Installing the front head restraints

1. Position the head restraint correctly above the head restraint guides and insert into the guides on the seat backrest.
2. Slide the head restraint downward until it engages into the guide rods.
3. Adjust the head restraint to the correct position.

Removing the rear head restraint



Fig. 66 Removing the rear head restraint (general example).

1. If necessary, adjust the seat backrest so that the head restraint can be removed.
2. Slide the head restraint all the way upward.
3. Pull the head restraint all the way out while pressing the *fig. 66* button.

Installing the rear head restraint

1. Release the backrest of the rear bench seat and fold forwards.
2. Position the head restraint correctly above the head restraint guides and insert into the guides on the seat backrest.
3. Push the head restraint downward while pressing the *fig. 66* button.
4. Fold the rear bench seat backrest toward the rear and lock it securely into place.

5. Adjust the head restraint to the correct position.

Seat functions

Center armrest

Front center armrest



Fig. 67 Front center armrest.

- To lift: Pull the center armrest up in the direction of the arrow *fig. 67*.
- To lower: Pull the center armrest up fully. Then press the center armrest down.

Depending on vehicle equipment, there may be a storage compartment located under the center armrest.

⚠ WARNING

If the front center armrest is opened all the way or not completely closed, it can limit the driver's ability to move his or her arms, which can cause accidents and serious injuries.

- Always keep the storage compartments closed while driving.
- Never allow an adult or child to ride on the center armrest. This incorrect seating position can cause serious injuries.

Rear center armrest



Fig. 68 Folding center armrest in the rear (general example).

There may be a folding armrest in the backrest of the rear center seat.

- To fold forward: pull the center armrest in the direction of the arrow *fig. 68*.
- To fold back: fold the center armrest upward in the opposite direction of the arrow *fig. 68* and press it all the way toward the seat backrest.

Passengers must not sit in the center rear seat when the center armrest is folded down.

⚠ WARNING

Incorrect use of the rear center armrest may cause serious injuries.

- The rear center armrest must always be folded up during journeys.
- If the center armrest is folded down, the center rear bench seat must never be used by either adults or children.
- Never allow an adult or child to ride on the center armrest.

Memory function

Memory buttons



Fig. 69 On the outer side of the driver's seat: memory buttons.

Driver seat and outside mirror settings can be saved and called up using the memory buttons.

Storing the driver's seat and outside mirror settings for driving forward

1. Set the electronic parking brake.
2. Shift the transmission to neutral.
3. Switch the ignition on.
4. Adjust the driver's seat and outside mirror.
5. Press and hold the **SET** *fig. 69* button for longer than one second.
6. Press the desired memory button within approximately ten seconds.

A chime will confirm that the settings were saved.

Storing the front passenger's outside mirror settings for driving in reverse

1. Set the electronic parking brake.
2. Shift the transmission to neutral.
3. Switch the ignition on.
4. Press the desired memory button *fig. 69*.
5. Select the reverse gear.
6. Adjust the front passenger's outside mirror so that the edge of the curb can be seen clearly, for example.

The selected mirror position will be stored automatically and assigned to the vehicle key that was used to unlock the vehicle.

Recalling driver's seat and outside mirror settings

1. When the vehicle is stationary, the ignition is switched off, and a door is open, press the respective memory button briefly.

After approximately ten minutes, the stored positions can no longer be adjusted automatically. The adjustment process will be canceled if one of the memory buttons is pressed again.

Or: When the ignition is switched on or the door is closed, press and hold the respective memory button until the saved positions are reached.

The front passenger's outside mirror automatically leaves the position stored for driving in reverse once you begin driving forward at speeds of at least approx. 15 km/h (approx. 10 mph) or when you turn the knob for the outside mirrors from the **R** position to another position.

ⓘ If you open the driver door more than approximately ten minutes after the vehicle is unlocked, the driver seat and the outside mirrors will not be adjusted automatically.

Front seat convenience entry function

Variant 1: When the driver door is opened, the driver seat moves automatically to a position that makes it easy to enter the vehicle. The driver seat automatically returns to its original position once you have closed the driver door and switched on the ignition.

Version 2: Before the vehicle is exited, the driver seat moves automatically to the rear position and remains there. After the vehicle is re-entered and the driver door is closed, the driver seat moves forwards to the last saved position.

The front seat convenience entry function can be enabled and disabled in the Infotainment system.

⚠ WARNING

Improper use of seat functions can cause injuries.

- Before beginning a journey always adjust to the correct seat position and maintain this throughout the journey. This also applies to all passengers.
- Set the memory function only with the vehicle stationary.
- Always keep your hands, fingers, feet and other parts of your body clear of the area in which the seats operate and move during adjustment.

¹⁾ Only if personalization has been activated.

Message feature



Fig. 70 Message function button to the side of the driver seat.

For the massage function, the lumbar support moves and massages the lumbar area of your back.

The lumbar support cushioning (intensity of the massage) can be individually adjusted in three stages during operation by pressing repeatedly on the corresponding switch ⇒ [Adjusting power front seats](#).

Switching the massage function on and off

1. To switch on, push the  button in the seat control panel. Press the  button again to switch off.

After around ten minutes, the massage function switches off automatically.

⚠ WARNING

Improper use of seat functions can cause injuries.

- Before beginning a journey always adjust to the correct seat position and maintain this throughout the journey. This also applies to all passengers.
- Only switch the massage function on and off when the vehicle is stationary.
- Always keep your hands, fingers, feet and other parts of your body clear of the range of operation and adjustment range of the seats.

Lights

Headlights

Switching the turn signals on and off

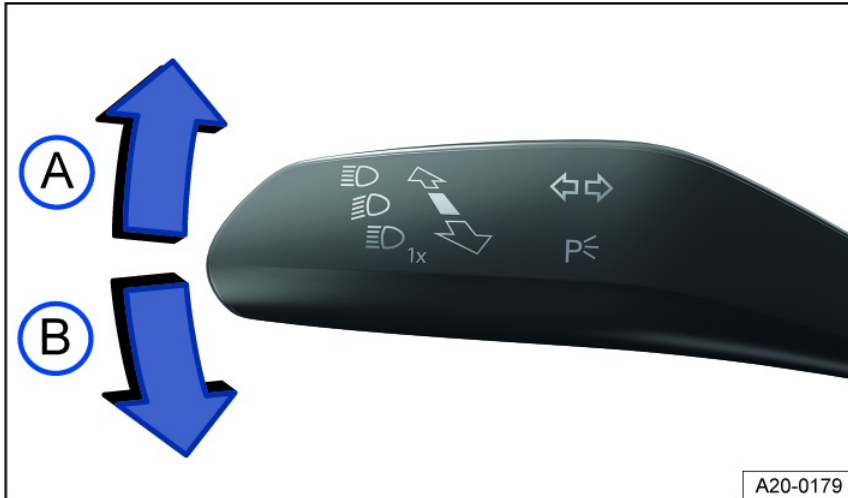

Fig. 71 On the left side of the steering column: turn signal and high beam lever.

- A Right turn signal ➔.
- B Left turn signal ➜.

Switching the turn signals on and off

1. Switch the ignition on.
2. Move the turn signal and high beam lever from the center position to the preferred position [fig. 71](#).
3. To cancel the turn signal, move the turn signal and headlamp lever back to its basic position.

If no chime sounds when the turn signal is on, contact suitably qualified professionals and have the vehicle checked. Volkswagen recommends contacting an authorized Volkswagen dealer or authorized Volkswagen Service Facility.

3-blink turn signal

To use the 3-blink turn signal, move the turn signal and high beam lever upward or downward to the pressure point and then release the lever. The turn signal will blink three times.

To stop the 3-blink turn signal before it ends, move the turn signal and high beam lever immediately to the pressure point in the opposite direction and release.

The 3-blink turn signal can be activated and deactivated in the vehicle settings in the Infotainment system ⇒ [Vehicle settings menu](#).

⚠ WARNING

Using the turn signals incorrectly, not using the turn signals, or forgetting to turn the turn signal off can mislead other road users. This can cause accidents and serious or fatal injuries.

- Always activate the turn signals correctly when changing lanes, passing, or turning.
- Switch the turn signal off again every time you finish changing lanes, passing, or turning.

 The emergency flashers also work when the ignition is switched off ⇒ [In case of an emergency](#).

Switching the lights on and off





Fig. 72 Next to the steering wheel: Button to switch on the exterior lighting.

Switching the lights on

1. Switch the ignition on.
2. Tap the  button repeatedly until the corresponding indicator lights come on.

 The low beam headlights are switched on. The green indicator light turns on.

AUTO Automatic headlights: The low beam headlights are switched on or off depending on the ambient brightness ⇒ , ⇒ *Automatic headlight control*.

 Parking light and daytime running light switched on; the green indicator light comes on. The automatic headlights are activated from a speed of approximately 10 km/h (approximately 6 mph) or after a distance driven of around 100 m (approximately 0.062 mi) **AUTO**.

OFF Display only in instrument cluster: Light switched off. The automatic headlights are activated from a speed of approximately 10 km/h (approximately 6 mph) or after a distance driven of around 100 m (approximately 0.062 mi) **AUTO**.

Switching the lights off

1. Switch the ignition off.

AUTO The orientation lighting can be switched on ⇒ *Entry and exit lighting (orientation lighting)*.

 The parking light is switched on ⇒ *Parking lights*. The green indicator light turns on.

OFF Display only in instrument cluster: Light switched off.

Daytime running lights

The daytime running lights can improve the vehicle's visibility in daytime traffic and switch on every time the ignition is switched on (when daylight is detected).

Daytime running lights parking function

Depending on the equipment, the vehicle may have a daytime running lights parking function to turn off the daytime running lights temporarily when the ignition is switched on.

Switch off the daytime running lights:

1. Switch the ignition on.
2. Switch the lights off.
3. Set the electronic parking brake.

Switch on the daytime running lights:

1. Switch off the electronic parking brake.

WARNING

If the vehicle lighting is not used appropriately for the weather conditions, the road will not be illuminated sufficiently. The vehicle will not be visible to other road users or will be difficult to see. This can cause accidents and serious or fatal injuries.

- Always turn on the low beam headlight in the dark, when it is raining, and when visibility is poor.
- Regularly check that the lighting system and turn signals are functioning correctly.

WARNING

The parking lights or daytime running lights are not bright enough to illuminate the road sufficiently and to be seen by other road users. The taillights do not switch on with the daytime running lights. Without its taillights turned on, the vehicle may not be seen by other road users in the dark, in the fog, and when

visibility is poor. This can cause accidents and serious or fatal injuries.

- Always turn on the low beam headlight in the dark, when it is raining, and when visibility is poor.

⚠ WARNING

The automatic headlights **AUTO** are for assistance only. The driver is always responsible for turning on the correct vehicle lighting. Automatic headlight control **AUTO** only turns the low beam headlights on and off when there are changes in brightness. Insufficient lighting on the road may cause accidents and serious or fatal injuries.

- Turn on the low beam headlights manually in certain weather conditions, such as in fog.

 When reverse gear is engaged, the cornering lights on both sides of the vehicle will turn on automatically to better illuminate the surroundings while maneuvering.

Switching the high beam headlights on and off

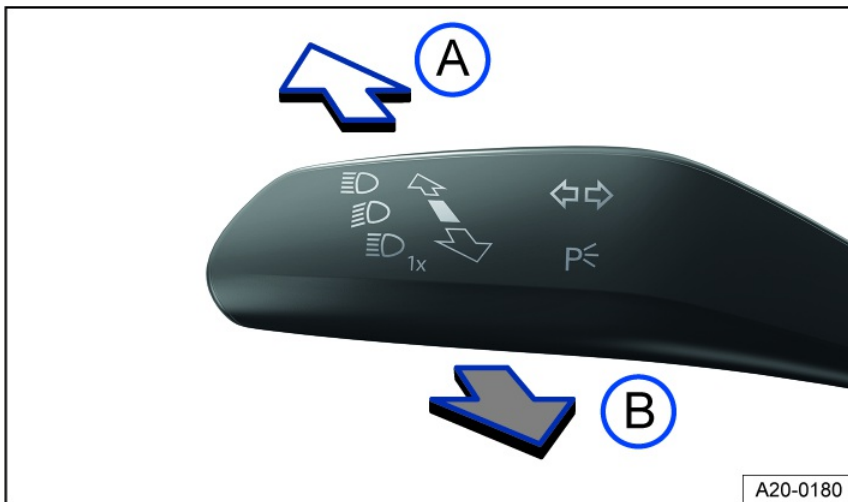





Fig. 73 On the left side of the steering column: turn signal and high beam lever.

- A**  Turn on the high beam headlight.
- B**  Activate the headlight flashers or turn off the high beam headlights.

If the high beam headlights or headlight flashers are turned on, the blue  indicator light will come on in the Volkswagen Digital Cockpit ⇒ .

Turning on the high beam headlight

1. Switch the ignition on.
2. Switch on the low beam headlight.
3. Press the turn signal and high beam lever forward out of the center position *fig. 73*.

Turning off the high beam headlight

1. Pull the turn signal and high beam lever backward out of the center position *fig. 73*.

Turning the headlight flasher on and off

1. Pull the turn signal and high beam lever backward out of the center position and hold it *fig. 73*.
Release the turn signal and high beam lever to turn the headlight flasher off.

Light Assist

Depending on the equipment, high beam control (Light Assist) may be available ⇒ *High Beam Control (Light Assist)*.

⚠ WARNING

Incorrect use of the high beam headlight may distract and blind other road users. This can cause accidents and serious or fatal injuries.

- Use the high beam headlights only if other road users cannot be distracted or blinded.

High Beam Control (Light Assist)



High beam control (Light Assist) switches off automatically if the system detects oncoming vehicles or vehicles driving ahead. In addition, Light Assist generally detects well-lit areas such as towns and deactivates the high beam headlights when driving through these areas.

The high beam headlights switch on and off automatically within the limits of the system, depending on the environmental and traffic conditions and the vehicle

speed ⇒ .

Switching on high beam control (Light Assist)

1. Switch on the ignition and the automatic headlights **AUTO**.
2. Tap the turn signal and high beam lever forward out of the basic position.

When Light Assist is switched on, the  indicator light in the instrument cluster display will turn on. When high beam control (Light Assist) is active, the blue indicator light  for the high beam headlight in the instrument cluster lights up.

Adjusting the sensitivity of Light Assist

Depending on the country, the sensitivity of Light Assist can be set in two stages:

- *Increasing the sensitivity:* press the turn signal and high beam lever forwards from its original position and hold it in this position for around 15 seconds.
The  indicator light on the instrument cluster will blink three times to confirm that this has been applied.
- *Setting the sensitivity back to its standard setting:* press the turn signal and high beam lever forwards from its original position and hold it in this position for around 15 seconds.

The  indicator light on the instrument cluster will blink three times in quick succession to confirm that this has been applied.

Or: Switch the ignition off and on.

Switching off high beam control (Light Assist)

1. Switch off **AUTO** automatic headlights.

Or: when Light Assist is switched on and active, pull the turn signal and high beam lever backward.

Or: if high beam control (Light Assist) is switched on and not active, tap the turn signal and high beam lever forward. The manual high beam headlights are now switched on. Pull the turn signal and high beam lever backwards to switch the high beam headlights off manually if necessary.

Or: Switch off the ignition.

System limitations

The high beams must be switched off manually in the following situations, because Light Assist may not switch them off at the right time or at all:

- In poorly lit towns which cannot be recognized as a town by the system.
- On poorly lit roads with strongly reflective signs.
- If there are others on the road who have inadequate lighting, such as pedestrians or cyclists.
- On tight curves where the view of traffic is partially obstructed, on steep rises, or in dips.
- When there are oncoming vehicles on roads with a center barrier and the drivers in the oncoming vehicle can clearly see above the barrier, for example truck drivers.
- In fog, snow, and heavy rain.
- When there are dust and sand in the air.
- If the windshield is damaged in the camera's field of vision.
- If the camera visual field is fogged over, dirty, or covered by a sticker, snow, or ice.
- If the camera switches off automatically due to a high ambient temperature or exposure to direct sunlight for a prolonged period. Light Assist will be available once the camera is available again.
- If the camera is faulty and the power supply is interrupted.

WARNING

Light Assist may not detect all traffic situations correctly and the function may be restricted in certain situations. High beam control (Light Assist) is only an aid. The driver is always responsible for turning on the correct vehicle lighting. Switching on the high beam headlight at the wrong time may distract and blind other road users. This can cause accidents and serious or fatal injuries.

- Always control the headlights yourself and adapt them to the lighting, visual, and traffic conditions.
- Switch the high beam off manually if it could blind other road users.

WARNING

If the camera lens is dirty, covered, or damaged, the Light Assist function may be limited. This is also the case if the vehicle lighting system is changed, such as by adding auxiliary headlights. This can cause accidents and serious or fatal injuries.

- Regularly clean the camera view area and keep it free of snow and ice.
- Do not cover the camera view area.
- Regularly check the windshield for damage in the camera lens area.

Dynamic cornering light

The dynamic cornering lights provide optimum illumination of the roadway.

The dynamic cornering light only works when the automatic headlights **AUTO** are switched on and at speeds of more than approximately 10 km/h (approximately 6 mph).

Switching the poor weather lights on and off

Poor weather lights help you to illuminate the carriageway more effectively when visibility is poor.

The poor weather lights can only be switched on when the ignition is switched on.



Switching on the Poor Weather Lights

1. Switch the ignition on.
2. Tap the  button ⇒ *Switching the lights on and off*.

The green indicator light in the button turns on. The  indicator light will also light up on the instrument cluster for a few seconds.

Switching off the Poor Weather Lights

1. Tap the  button again.

 If the poor weather lights are switched on when the light is off **OFF**, the parking lights are switched on  or the automatic headlights **AUTO** are switched on, the low beam headlights will also be switched on, regardless of the ambient brightness.

Troubleshooting

Turn signal indicator light

The green indicator light blinks.

If a turn signal light on the vehicle is not working, the indicator light will blink twice as fast.

1. Check the lights and replace any bulbs as necessary ⇒  [Introduction](#).
2. If the malfunction persists, contact a suitably qualified professional. Volkswagen recommends contacting an authorized Volkswagen dealer or authorized Volkswagen Service Facility.

Trailer turn signal indicator light

The green indicator light blinks.

If a trailer turn signal or the entire trailer light system is out, the indicator light will turn off.

1. Check the lights and replace any bulbs as necessary ⇒  [Introduction](#).
2. If the malfunction persists, contact a suitably qualified professional. Volkswagen recommends contacting an authorized Volkswagen dealer or authorized Volkswagen Service Facility.

Exterior lighting malfunction

The yellow indicator light turns on.

The headlights have completely or partially failed.

1. Check the lights and replace any bulbs as necessary ⇒  [Introduction](#).
2. If the malfunction persists, contact a suitably qualified professional. Volkswagen recommends contacting an authorized Volkswagen dealer or authorized Volkswagen Service Facility.

Rain/light sensor malfunction

The yellow indicator light turns on.

If the automatic headlights (**AUTO**) are switched on, the vehicle lighting will not turn on or off automatically.

1. Switch the ignition off and on.
2. If the malfunction persists, contact a suitably qualified professional. Volkswagen recommends contacting an authorized Volkswagen dealer or authorized Volkswagen Service Facility.

Dynamic cornering light

The swinging behavior of the bulbs can be influenced by the selected driving mode in vehicles with driving mode selection.

If the dynamic cornering light malfunctions, this is indicated on the instrument cluster display. Contact a suitably qualified professional. Volkswagen recommends contacting an authorized Volkswagen dealer or authorized Volkswagen Service Facility.

Controls are responding differently than expected

Moisture, dirt and grease may limit the functioning of the controls.

1. Always keep the control panels clean and dry.

Parking lights

Parking lights

Parking lights

If the  parking light function is switched on, both headlights will come on, along with the parking lights, sections of the taillights, the license plate light and various buttons in the vehicle interior.

Automatic parking light deactivation

The vehicle detects that the 12 V vehicle battery is low and switches off the parking light early enough to ensure that the vehicle's drive system can still be activated but not until at least two hours have passed.

If the battery does not have enough capacity for the parking light to run for two hours, the 12 V vehicle battery may drain to such an extent that the vehicle's drive system can no longer be activated.

WARNING

If the vehicle is stopped without enough lighting and cannot be seen or is difficult for others on the road to see, this can cause accidents and serious or fatal injuries.

- Always stop the vehicle safely and with enough lighting.
- Follow the country-specific legal regulations.

Entry and exit lighting (orientation lighting)

When you are entering and exiting the vehicle in the dark, the entry and exit lighting illuminates the immediate area around the vehicle.

The entry and exit lighting is automatically controlled by a light sensor.

Switching on entry lighting

1. Unlock the vehicle when the automatic headlights **AUTO** are switched on and the light sensor detects *darkness*.

Switching off entry lighting

1. Turns off automatically after the lighting time has elapsed.

Or: Lock the vehicle.

Or: Press the  button repeatedly until the **OFF** setting is displayed in the instrument cluster.

Or: Switch on the ignition.

Switching on exit lighting

1. Switch the ignition off.

The exit lighting switches on when the automatic headlights **AUTO** are switched on and the light sensor detects *darkness*.

The *lighting time* begins when the last vehicle door or trunk lid is closed.

Switching off exit lighting

1. Turns off automatically after the set lighting time has elapsed.

Or: Automatically if a vehicle door or the trunk lid is still open approximately 30 seconds after switching on.

Or: Press the  button repeatedly until the **OFF** setting is displayed in the instrument cluster.

Or: Switch on the ignition.

Adjusting entry and exit lighting

The lighting time can be adjusted in the vehicle settings in the Infotainment system and the function can be activated or deactivated → [Vehicle settings menu](#).

Depending on the vehicle equipment, you can adjust the behavior of the exterior lighting in the vehicle settings in the Infotainment system.

You can choose between two display strategies in the Convenience lighting settings menu:

- Classic entry and exit lighting.

The periphery lighting, headlights and taillights are switched on and off at the same time.

- Dynamic entry and exit lighting.

The ambient lighting, headlights and taillights are switched on and off dynamically and, if necessary, in an animated pattern.

In vehicles with Keyless Access with push-button start, switching on the entry lighting when approaching can be activated or deactivated.

Light functions

Cornering lights

If the low beam headlights are switched on, a cornering light will also switch on during slow turns or in very tight corners.

 When reverse gear is engaged, the cornering lights on both sides of the vehicle will turn on automatically to better illuminate the surroundings while maneuvering.

Automatic headlight control

If automatic headlights **AUTO** are switched on, the vehicle lighting switches on and off automatically along with the instrument illumination under the following conditions:

- The light sensor has detected darkness.
- The windshield wipers are switched on for a long time.

When the lights are turned on, the yellow indicator light **AUTO** turns on ⇒ *Switching the lights on and off*.

Automatic headlight control is merely an aid and cannot always accurately detect all driving situations.

If the vehicle is equipped accordingly, the activation time of the automatic headlights can be adjusted in the vehicle settings in the Infotainment system ⇒ *Vehicle settings menu*.

Headlight range control

The headlight range must always be adapted to the vehicle load level. This provides the driver with the best possible visibility and oncoming traffic is not dazzled. To find out whether your vehicle features headlight range control, contact an authorized Volkswagen dealer or authorized Volkswagen Service Facility. Volkswagen recommends contacting an authorized Volkswagen dealer or authorized Volkswagen Service Facility.

Without headlight range control

The beam of the low beam headlights must be adjusted by an authorized Volkswagen dealer or authorized Volkswagen Service Facility to take into account the vehicle's load ⇒ . Volkswagen recommends contacting an authorized Volkswagen dealer or authorized Volkswagen Service Facility.

Dynamic headlight range control

The headlight range automatically adjusts to the vehicle load when the headlights are switched on ⇒ .

WARNING

Heavy objects in the vehicle can affect the vehicle level in such a way that causes the headlights to dazzle and distract other road users. This can cause accidents and serious or fatal injuries.

- Always adjust the light cone to the vehicle load so that other road users are not dazzled.

WARNING

If the headlight range control fails or malfunctions, the headlights may blind and distract other road users. This can cause accidents and serious or fatal injuries.

- Have the headlight range control inspected immediately by an authorized Volkswagen dealer or authorized Volkswagen Service Facility. Volkswagen recommends contacting an authorized Volkswagen dealer or authorized Volkswagen Service Facility.

Warning tones when lights are not turned off

If the ignition has been switched off and the driver door is opened, warning tones will sound under the following conditions:

- With the side lights switched on ⇒ .

If the orientation lighting is switched on, the warning tone to indicate that the light is still turned on will not sound when leaving the vehicle ⇒ *Entry and exit lighting (orientation lighting)*.

Interior lighting

Instrument and switch illumination

You can adjust the brightness of the instrument illumination in the vehicle settings in the Infotainment system ⇒ *Vehicle settings menu*.

The selected brightness will automatically adjust to the changing brightness in the vehicle.

If the automatic headlight control **AUTO** is switched on, a sensor switches the low beam headlights and the instrument and switch lighting on and off automatically based on outside brightness.

Interior/reading lights, ambient lighting



Fig. 74 On the overhead console: touch-sensitive reading lights.

Switching on or off interior and reading lights

Tap the corresponding symbol:

 **Switch the interior lights on or off.**  **Function switched off: the interior lights will switch on automatically when unlocking or leaving the vehicle.**

Touch-sensitive reading lights with manual dimming function

On the roof console and above the rear door, there can be touch-sensitive reading lights depending on the equipment [fig. 74](#). By tapping the illuminated area, the respective reading light can be switched on or off.

To activate the manual dimming function, touch the illuminated area until the desired brightness level is reached.

Glove compartment and luggage compartment lights

The glove compartment and the luggage compartment may be illuminated depending on the vehicle equipment.

The relevant light turns on or off when opening and closing the glove compartment or trunk lid.

Ambient lighting

Ambient lighting can provide indirect lighting in various areas of the vehicle interior.

The brightness and, depending on the vehicle equipment, the color of the ambient lighting, can be adjusted in the Ambient light menu in the Infotainment system [⇒ Vehicle settings menu](#). If you select the setting Auto, the color of the ambient lighting changes depending on the driving mode setting.

 **After the ignition has been switched off, the lights will turn off when the vehicle is locked or automatically after a few minutes. This reduces the risk of the 12 V vehicle battery being drained.**

Visibility

Window wipers

Operating the windshield wiper lever

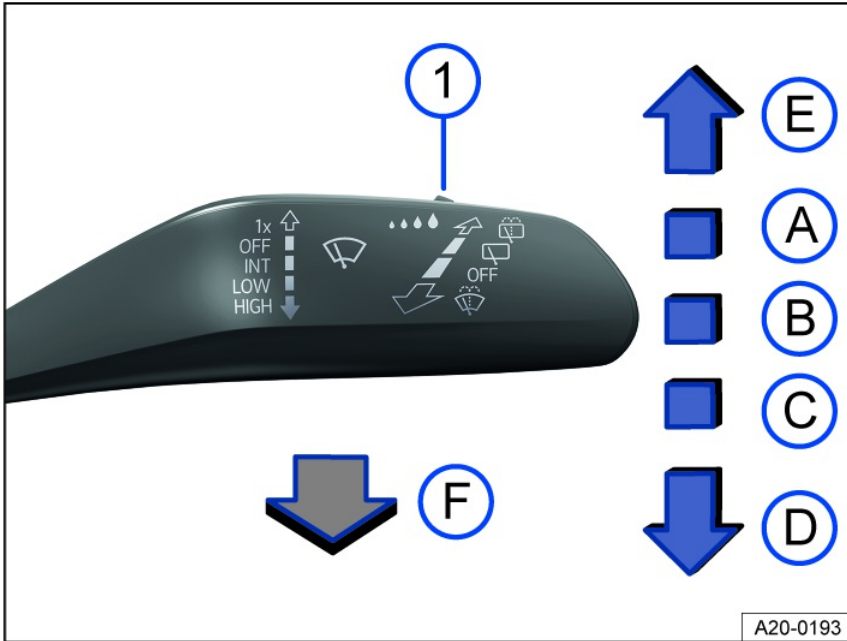











Fig. 75 On the right side of the steering column: operating the windshield wipers.

The windshield wipers only function when the ignition is switched on and the driver door, front passenger door, the hood and trunk lid are closed. Move the wiper lever into the desired position ⇒ :

-  **OFF** Wipers are switched off.
-  **INT** Interval wiping for the windshield or rain sensor mode. Interval wiping for the windshield depends on the driving speed. The higher the speed, the faster the wipers will move.
-  **LOW** Slow wiper speed.
-  **HIGH** Fast wiping.
-  **1x** One-tap wiping – brief wiping. Hold the lever down for longer to increase the wiper speed.
-   Pull the lever to activate the automatic wiper/washer system to clean the windshield. While the wiper/washer system is active, the Climatronic system switches to recirculation mode for approximately 30 seconds to help prevent the washer fluid odor from entering the vehicle interior.
-  **••••** Switch for interval levels (vehicles without rain/light sensor) or to adjust the sensitivity of the rain/light sensor.

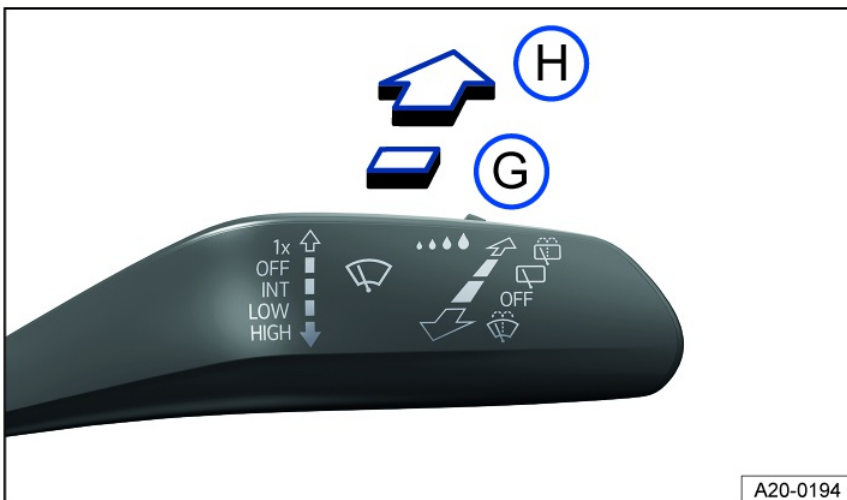







Fig. 76 On the right side of the steering column: operating the rear window wiper.

Move the wiper lever into the desired position ⇒ :

-   Interval wiping for the rear window. The wiper moves approximately every six seconds.
-   Press the lever to activate the automatic wiper/washer system to clean the rear window.

Without the sufficient freeze protection, washer fluid can freeze on the window glass and reduce visibility. This can cause accidents and serious or fatal injuries.

- Only use the washer system with sufficient freeze protection in winter temperatures.
- Never use the window washer system in winter temperatures if the windshield has not been warmed up with the air conditioning system.

⚠ WARNING

Worn or dirty wiper blades reduce visibility and increase the risk of accidents and serious injuries.

- Always replace wiper blades if they are damaged or worn and are no longer cleaning the window glass sufficiently ⇒ [Cleaning and changing wiper blades](#).

ⓘ NOTICE

Incorrect handling of the windshield wipers can cause damage to the windshield, the wiper blades and the wiper motor.

- Before driving and before the ignition is switched on, check that the windshield wiper lever is in the basic position.
- Remove any snow and ice from the windshield wipers and the windshield.
- Always carefully loosen wiper blades that have frozen onto the windshield from the windshield.
- Do not turn on the windshield wipers when the windshield is dry.

ⓘ The activated wiper speed temporarily changes to the next lower speed when the vehicle is stationary.

ⓘ If the driver or front passenger door is opened when the vehicle is stationary, then the windshield wipers return to their initial position and are switched off. If the door is shut again within a few seconds or the windshield wiper lever is moved, the windshield wipers are switched back on again.

ⓘ When parking the vehicle in cold weather conditions, moving the windshield wipers to the service position may be helpful for loosening the wiper blades more easily from the windshield ⇒ [Cleaning and changing wiper blades](#).

Wiper function

Automatic rear window wiping

The rear window wiper switches on automatically when the windshield wipers are switched on and reverse gear is engaged. The automatic activation in reverse gear function can be activated and deactivated in the vehicle settings in the Infotainment system ⇒ [Vehicle settings menu](#).

Heated washer nozzles

The heat thaws frozen washer fluid nozzles. The heat output is automatically regulated when the ignition is switched on and is dependent on the outside temperature. Only the window washer nozzles are heated and not the washer fluid hoses.

Cleaning system of the Rear View Camera system

The cleaning system of the Rear View Camera system cleans the Rear View Camera system and works with the automatic wiper washing system to clean the rear window.

If, after washing the camera several times, the camera's view is still limited, clean the camera lens manually ⇒ [Rear view](#), ⇒ [Exterior care and cleaning](#).

Rain/light sensor



Fig. 77 On the right side of the steering column: windshield wiper lever.

1 Switch for adjusting the sensitivity of the rain/light sensor.

A Rain/light sensor deactivated.

B Rain/light sensor activated, automatic wiping as necessary.

When switched on, the rain/light sensor automatically shortens or lengthens the delay between wiping cycles depending on how hard it is raining.

Activating and deactivating the rain/light sensor

1. Press the lever into the desired position *fig. 77*.

Automatic wiping can be activated and deactivated in the vehicle settings in the Infotainment system ⇒ *Vehicle settings menu*.

If automatic wiping is deactivated in the Infotainment system, the interval time will be set in fixed stages.

Adjusting the sensitivity of the rain/light sensor

The sensitivity of the rain/light sensor can be manually adjusted with the switch in the windshield wiper lever *fig. 77*, ⇒ .

- Move the switch to the right – high sensitivity.
- Move the switch to the left – low sensitivity.

WARNING

The rain/light sensor cannot detect all precipitation sufficiently and activate the windshield wipers accordingly. Reduced visibility can cause accidents and serious or fatal injuries.

- If necessary, switch on the windshield wipers manually if water on the windshield is impairing visibility.

Troubleshooting

Washer fluid level too low

The yellow indicator light turns on.

1. Fill the washer fluid reservoir ⇒ *Washer fluid*.

Windshield wiper malfunction

The yellow indicator light turns on.

The windshield wipers are not working.

1. Switch the ignition off and on.
2. If the malfunction persists, contact a suitably qualified professional. Volkswagen recommends contacting an authorized Volkswagen dealer or authorized Volkswagen Service Facility.

Rain/light sensor malfunction

The yellow indicator light turns on.

The windshield wipers will not be automatically activated in rain/light sensor mode when it is raining.

1. Switch the ignition off and on.
2. If the malfunction persists, contact a suitably qualified professional. Volkswagen recommends contacting an authorized Volkswagen dealer or authorized Volkswagen Service Facility.

Changes to rain/light sensor reaction

Some possible reasons for malfunctions and misinterpretations in the sensor area of the rain/light sensor ⇒ *View from the front* could be:

- **Damaged wiper blades:** damaged wiper blades can leave a film of water or streaks on the window, and this can extend the activation time, greatly shorten the wiper intervals, or cause fast wiping time.
- **Insects:** insects hitting the windshield may trigger the wipers.
- **Salt streaks:** salt streaks on the windshield from driving in the winter can cause the wipers to wipe more frequently or continuously on a window that is almost dry.
- **Dirt:** dried dust, wax, any other build-up on the windshield (lotus effect), or washing product residue (car wash) can lower the sensitivity of the rain/light sensor and cause it to react too slowly or not at all. Clean the sensor area for the rain/light sensor regularly and check the wiper blades for damage ⇒ *Exterior care and cleaning*.
- **Crack in the windshield:** if a stone strikes and chips the sensor area while the rain/light sensor is on, this will trigger a wiper cycle. After that, the rain/light sensor will detect this irregularity on the sensor surface and react to it. Depending on the size of the chip, the reaction behavior of the rain/light sensor may or may not change.

 If there is an obstacle for the wipers on the window glass, the wipers will attempt to remove it. If it continues to block the wipers, the wipers will stop moving.

1. Remove the obstacle and switch the wipers on again.

Mirrors

General safety precautions

Using the outside mirrors and the interior rearview mirror, the driver can observe traffic and adjust their driving based on traffic.

For driving safety, it is important that the driver adjusts the outside mirrors and the interior rearview mirror correctly before starting to drive.

It is not possible to oversee the entire side and rear area of the vehicle by looking in the outside and interior rearview mirrors. These areas that are not visible are called blind spots. Other road users and objects could be in the blind spot.

WARNING

Adjusting the outside mirrors and interior rearview mirror while driving can distract the driver. This can cause accidents and serious or fatal injuries.

- Only adjust the outside mirror and interior rearview mirror when the vehicle is stationary.
- Always make sure that the mirrors are adjusted correctly and visibility to the rear is not limited by ice, snow, fog, or other objects.

WARNING

The view in the outside mirrors and interior rearview mirror does not cover the entire area around the side and rear of the vehicle. Other road users and objects could be in these blind spots. This can cause accidents and serious or fatal injuries.

- When parking, changing lanes, passing, and turning, always pay attention to your surroundings.

WARNING

Curved mirror surfaces (convex or aspheric) enlarge the field of vision and allow objects in the mirror to appear smaller and farther away. This can make it difficult to estimate the exact distance from the vehicles behind, e.g. when changing lane. This can cause accidents and serious or fatal injuries.

- Use the interior rearview mirror as much as possible to more accurately determine the distance to vehicles or other objects behind you.
- Make sure there is sufficient visibility of the area behind the vehicle.

WARNING

An automatic dimming rearview mirror contains an electrolyte fluid that can leak out if the mirror glass breaks. Coming into contact with this liquid can irritate the skin, eyes, and respiratory organs, especially in individuals with asthma or similar illnesses. This may cause serious injuries.

- If electrolyte fluid is swallowed, rinse out the mouth immediately for at least 15 minutes with plenty of water. Do not induce vomiting unless it ordered to do so by a doctor. Call for medical assistance immediately.
- Immediately get plenty of fresh air and exit the vehicle. If this is not possible, open all the windows and doors.
- If the electrolyte fluid comes into contact with eyes or skin, wash the affected area immediately for at least 15 minutes with plenty of water and seek medical assistance.
- If the electrolyte fluid comes into contact with your shoes or clothing, wash it for at least 15 minutes with plenty of water. Clean the shoes and clothing thoroughly before wearing them again.

NOTICE

If the glass on an automatic dimming mirror breaks, electrolyte fluid can leak out. This fluid damages plastic surfaces.

- Remove any leaking fluid as soon as possible, for instance using a wet sponge.

Interior rearview mirror

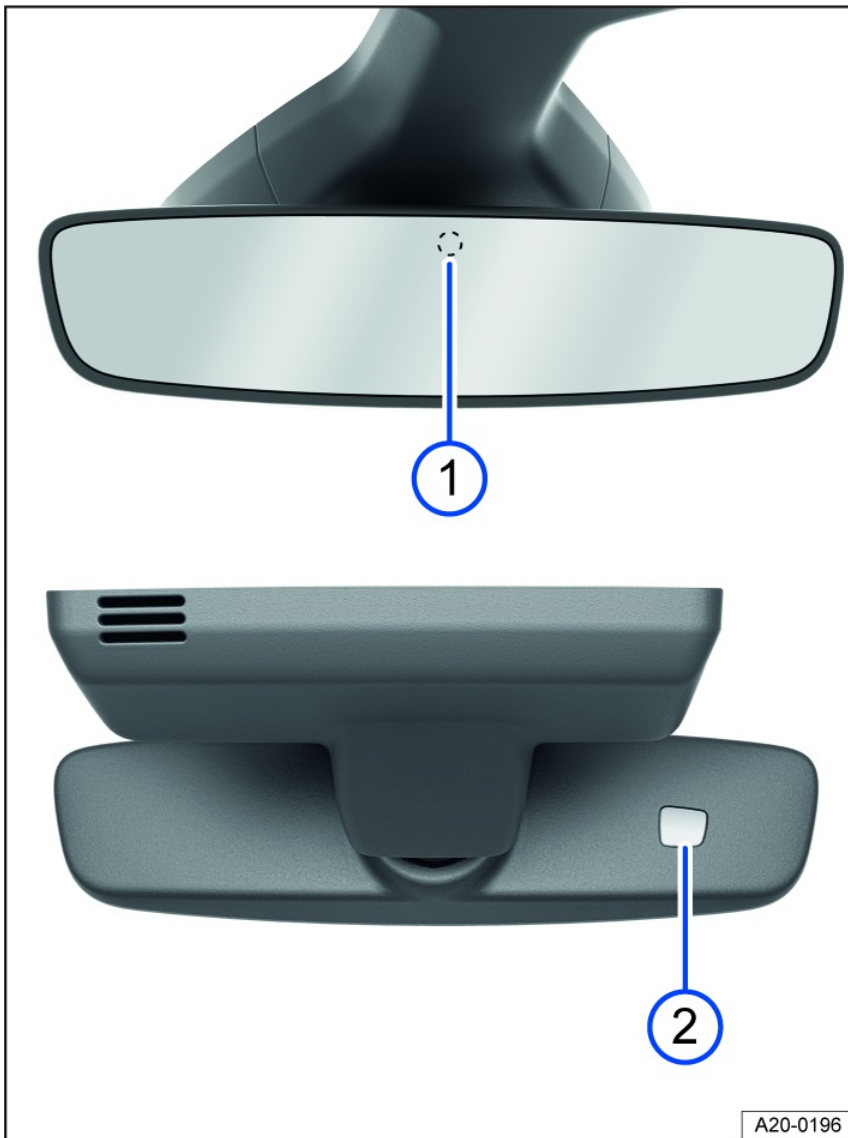

A20-0196

Fig. 78 On the windshield: automatic dimming interior rearview mirror.

- ① Sensor for light entering from the rear.
- ② Sensor for light entering from the front.

Automatic dimming interior rearview mirror

When the ignition is on, the sensors measure the amount of light entering from the rear *fig. 78* ① and from the front ②.

Depending on the measured values, the interior rearview mirror will dim *automatically*.

If the amount of light entering the sensors is limited or interrupted, for example by a sunshade or attachment, the automatic dimming interior rearview mirror may not function or may malfunction. Mobile navigation devices on the windshield or near the automatic dimming interior rearview mirror can also affect the sensors ⇒ ⚠.

Automatic dimming will be deactivated in some situations, for example when reverse gear is engaged.

⚠ WARNING

The illuminated display of a mobile navigation system may interfere with the automatic dimming interior rearview mirror. This may stop you from using the interior rearview mirror to accurately determine the distance from vehicles or other objects behind you. Accidents and serious or fatal injuries could result.

- Switch the mobile navigation system off in such cases.

Outside mirrors





Fig. 79 In the driver door: knob for the outside mirrors.

The following information describes the outside mirror functions for left-hand drive vehicles. Position **L** corresponds to the outside mirror on the driver's side, and position **R** corresponds to the outside mirror on the passenger's side. For right-hand drive vehicles, proceed in the reverse order.

Adjusting outside mirrors

1. Switch the ignition on.
2. Turn the knob in the driver door until the desired symbol lights up [fig. 79](#).
3. To adjust the outside mirror, push the knob forward, back, right or left in the direction of the arrow.

The corresponding symbol remains lit while the selected function is active.

 Fold the outside mirror in towards the vehicle body ⇒ .

 Switch on the outside mirror heating. The exterior mirror heating only works when the ambient temperature is below approx. 20 °C (around 68 °F) and provides the most heat when it first turns on. After about two minutes, the mirrors will be heated depending on the ambient temperature.

L Adjusts the left outside mirror.

R Adjusts the right outside mirror.

Activating outside mirror functions

The following outside mirror functions must be activated in the vehicle settings in the Infotainment system before they are used for the first time ⇒ [Vehicle setting: menu](#).

Synchronized mirror adjustment

The synchronized mirror adjustment feature simultaneously adjusts the right-side outside mirror to match adjustments to the left-side outside mirror.

1. Turn rotary knob to position **L**.
2. Adjusts the left outside mirror. The right outside mirror will be adjusted the same way (synchronized).
3. To correct the adjustment of the right outside mirror, if necessary, turn the knob to the **R** position and adjust the right outside mirror.

Folding the outside mirrors in while parking

If the vehicle is locked or unlocked from the outside, the outside mirrors can automatically fold in or out, depending on the vehicle equipment. For this to happen, the knob must be in the , **L**, **R** position.

If the knob for power exterior mirrors is in the  position, the outside mirrors will remain folded in.

Save the passenger-side outside mirror settings when reversing

1. Unlock the vehicle using the key, to which the setting is allocated.
2. Select the reverse gear.
3. Adjust the front passenger outside mirror so that, for example, the edge of the curb can be seen clearly.
4. Shift the transmission to neutral.
5. Switch the ignition off.

The selected mirror position will be stored and assigned to the vehicle key.

Opening the front passenger outside mirror settings for driving in reverse

1. Turn rotary knob for the outside mirrors to the relevant position for adjusting the front passenger outside mirror.
2. With the ignition switched on, select reverse gear.

The front passenger outside mirror will adjust to the stored position.

The front passenger outside mirror will exit the position stored for driving in reverse when you begin driving forward faster than about 15 km/h (about 9 mph) or when the knob is turned to any other position.

⚠ WARNING

If you fold the outside mirrors against the vehicle or back without taking care, you could get your fingers jammed between the outside mirror and the mirror base. This can cause serious injuries.

- Do not fold the outside mirrors out or in if there are any obstacles in the path.

ⓘ NOTICE

If outside mirrors are not folded in when driving through a car wash, they can get damaged.

- Always fold in the outside mirrors.

ⓘ NOTICE

Folding in the power exterior mirror manually can worsen wear and tear or damage the mirror motor.

- Do not fold power exterior mirrors in or out by hand.

🌿 Leave the outside mirror heating on only as long as it is needed. Otherwise power will be used unnecessarily.

🔧 If there is a malfunction in the power outside mirror, you can adjust the position of the mirror manually by hand by pushing on the edge of the mirror surface.

Sunshade

Sun visors

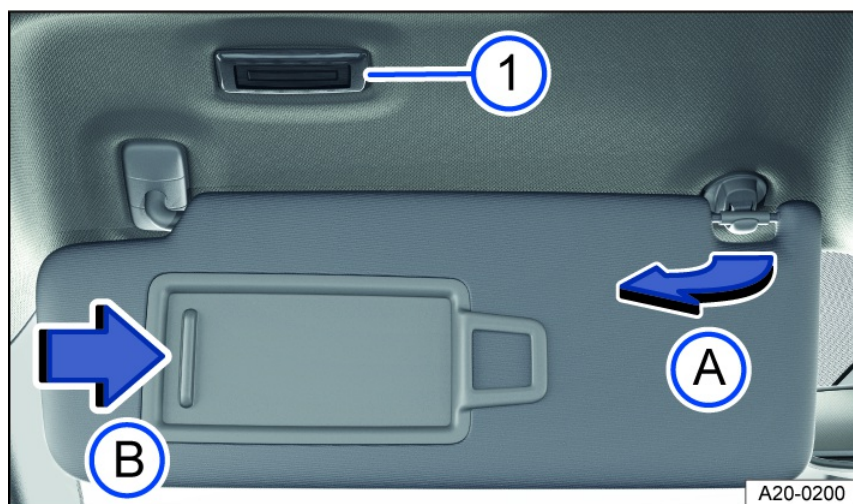

Fig. 80 In the front of the headliner: sun visor.

- ① Light.
- Ⓐ Remove from holder.
- Ⓑ Slide cover open.

Adjustment options for the driver and front passenger sun visors

- Fold toward the windshield.
- Remove from the holder and tilt toward the door *fig. 80*.
- Slide the sun visor that is swung towards the door backwards in a longitudinal direction ⇒ ⚠.

Illuminated vanity mirror

When the sun visor is folded down, there is a vanity mirror located behind a cover.

1. To open, push the cover in the direction of the arrow *fig. 80*.

The light *fig. 80* comes on when the cover is pushed open.

⚠ WARNING

Visibility may be reduced when sun visors are folded down and the sunshades are extended. This can cause accidents and serious or fatal injuries.

- Always guide sun visors and sunshades back into their holders when they are no longer needed.

i Under certain conditions, the light above the sun visor will turn off automatically after several minutes. This reduces the risk of the 12 V vehicle battery being drained.

Sunshade in the sunroof



Fig. 81 In the headliner: Function keys for controlling the sunshade.

The electronic sunshade works when the ignition is switched on and can be opened or closed via the function key in the headliner or in the vehicle settings in the Infotainment system.

If corresponding equipment is present, the sunshade can be opened and closed using voice control ⇒ *Vehicle settings menu*.

Opening the sunshade

- Automatic process: Swipe backward on the function key *fig. 81*. The automatic process is interrupted if the function keys are tapped.
- Manual process: Swipe backward on the function key and hold until it reaches the desired position.

Closing the sunshade

- Automatic process: Swipe forward on the function key *fig. 81*. The automatic process is interrupted if the function keys are tapped.
- Manual process: Swipe forward on the function key and hold until it reaches the desired position.

Sunshade pinch protection

The pinch protection can reduce the risk of being pinched and injured when the sunshade is closing ⇒ **⚠**. If the sunshade encounters resistance or an obstacle when closing, the sunroof will open again immediately.

1. Check why the sunroof did not close.
2. Try again to close the sunshade.

If the sunshade still encounters resistance or an obstacle and will not close, open the sunshade again. Within a short time after opening, you can close the sunshade again without pinch protection.

3. If the sunshade is still not able to close, close the sunshade without pinch protection.

Closing the sunshade without pinch protection

1. Try again to close the sunshade.
2. If the sunshade still cannot be closed, swipe forward on the function key within 5 seconds *fig. 81* and hold until the sunshade is completely closed.

This will close the sunshade without pinch protection.

3. If the sunshade still will not close, contact an authorized Volkswagen dealer or authorized Volkswagen Service Facility for assistance. Volkswagen recommends contacting an authorized Volkswagen dealer or authorized Volkswagen Service Facility.

If you release the function key during the closing process, the sunshade will open again automatically.

Control is responding differently than expected

Moisture, dirt and grease may limit the functioning of the control.

1. Always keep the control clean and dry.

⚠ WARNING

Closing the sunshade without pinch protection may result in serious injuries.

- Always be careful when closing the sunshade.
- Ensure that nobody is within the range of operation of the sunshade, especially if it is closing without pinch protection.

Windshield with communication window



Fig. 82 Next to the mirror base: Communication window (general example).

Windshields made of heat protection glass may have an infrared-reflecting coating and may, depending on the vehicle equipment, be able to be wirelessly heated. In order to ensure that wireless equipment from the accessories industry, e.g. toll systems, can function correctly, an uncoated area is present on either side of the interior rearview mirror (communication window) *fig. 82*.

The uncoated areas must not be covered from the inside or outside, or have stickers on them, because this could cause malfunctions.

Heating and air conditioning system

Climatronic

Overview of the Climatronic

Climatronic is an automatic air conditioning system which warms, cools and dehumidifies the air. In automatic mode, Climatronic can automatically control the air temperature, air distribution and the volume of air.

The air conditioner is most effective when the vehicle interior is kept closed. If there is a build-up of heat inside the vehicle, ventilation can help to speed up the cooling process.

Some functions of the air conditioner, as well as a climate control bar for the rear seats, depend on the vehicle equipment.

Display of activated functions

Illuminated symbols on the sensor areas indicate that a function is activated.

In the Air conditioner menu in the Infotainment system, function keys highlighted in color indicate that a function is switched on ⇒ [Air conditioner menu in the Infotainment system](#).

Air conditioner with voice command operation

Some of the air conditioner functions can be operated with voice control, depending on the vehicle equipment ⇒ [Voice control](#).

WARNING

Icy, snow-covered or misted windows greatly reduce visibility. This increases the risk of collisions and accidents that could result in serious or fatal injuries.

- Keep all windows free of ice, snow and fog.
- Adjust the heating, air conditioner, and rear window defroster to a setting where the windows do not fog up ⇒ [Troubleshooting](#).
- Only start driving when all windows are clear.
- Only use recirculation mode for a short time. Otherwise, the windows could fog up very quickly and greatly reduce visibility.
- Switch off air recirculation as soon as it is no longer needed.

Air conditioner menu in the Infotainment system

In the upper center console

 **Open the Air conditioner menu in the Infotainment system.**

In the Classic Climate and Smart Climate submenus, you can find, for example, the functions for temperature regulation ⇒ [Temperature regulation](#) and air distribution ⇒ [Air distribution and blower speed](#).

Depending on the vehicle equipment, the Classic Climate menu may also be called Climate control.

The Smart Climate submenu is available depending on the vehicle equipment.

Climate control settings submenu

 **Open the Climate control settings submenu.**



Depending on the vehicle equipment, you can find additional comfort functions in the Climate control settings submenu:

- Switch on seat heating automatically at the beginning of the journey ⇒ [Seat heating](#).
- Switch on steering wheel heating automatically at the beginning of the journey ⇒ [Steering wheel heating](#).

Switching the Climatronic on and off

In the Air conditioner menu: top of the screen

 **Switch the air conditioning system on and off.**

1. Tap  in the upper center console.
2. Tap  in the Air conditioner menu.

Automatic mode of the Climatronic

In the air conditioner menu

AUTO The set air temperature is maintained constant. The air volume and air distribution are automatically controlled. Automatic mode switches off when the blower speed is changed manually.

If a Smart Climate function is switched on, Climatronic automatic mode is also switched on ⇒ [Air distribution and blower speed](#).

Selecting the air conditioner profile

The blower power in automatic mode can be controlled via the air conditioning profiles.

1. Open the Air conditioner menu in the Infotainment system.
2. Tap **AUTO**.
3. Select your preferred air conditioner profile in the pop-up window.

Air Care

In the Air conditioner menu: Air Care submenu

The Air Care Climatronic active combination filter can limit the entrance of hazardous substances as well as allergens.

If Air Care is switched on, the air recirculation of the air conditioner is maximized as far as permitted by the risk of fogging up the windows depending on the humidity in the vehicle interior and the outside temperature. Air recirculation is controlled automatically and adapts itself continuously to prevent vehicle occupant fatigue.

Switching Air Care on and off

1. Open the Air conditioner menu in the Infotainment system.
2. Tap Air Care.
3. Tap Active.

Temperature regulation

in the Infotainment system: Bottom of the screen

  **Adjust the temperature. The temperature settings are displayed permanently at the bottom of the screen in the Infotainment system.**

The set temperatures for the rear seats are shown on the climate control bar displays for the rear seats.

In the Air conditioner menu: Classic Climate submenu

Depending on the vehicle equipment, the Classic Climate menu may also be called Climate control.



A/C **The air is cooled and dehumidified in cooling mode.** MAX A/C **Switch the maximum cooling output on and off.**

Air recirculation is switched on automatically and Climatronic automatically directs air to the upper body.

SYNC **Apply temperature settings for the driver side to all seats.**

On the Infotainment system: setting the temperature with the touch control

Depending on the equipment, you can set the temperature via the touch control on the Infotainment system.

1. To set the temperature of the Climatronic to +22 °C (+72 °F), tap and hold the touch control in the center between  and .

Or: to set a different temperature, swipe to the right or left on the touch control.

The set temperatures are displayed at the bottom of the screen in the Infotainment system.

In the Infotainment system: Stationary air conditioning menu

 **Open the Stationary air conditioning menu in the Infotainment system** ⇒ *Stationary air conditioning*.



Climate control depending on the seat

To make sure the power usage of the climate control system is as efficient as possible, the climate control operates based on whether the seat is occupied. If a seat is not occupied, Eco can be displayed instead of the temperature in the Air conditioner menu in the Infotainment system.

If a seat is occupied by a person wearing a seat belt, the vehicle recognizes the occupied seat when the vehicle's drive system is operational.

Adjusting the temperature for the rear seats

REAR **Open the settings for the rear seats.**

1. Open the Air conditioner menu in the Infotainment system.
2. Tap **REAR**.
3. Tap the  or  function key.

Or: tap  or  on the climate control bar for the rear seats.

The set temperatures for the rear seats are shown on the climate control bar displays for the rear seats.

 **If REAR LOCK is activated in the Infotainment system, the rear climate control bar cannot be used.**

Air distribution and blower speed

Vents

Vents are located in the following places in the vehicle:





- Driver's side.
- Passenger's side.
- Front center console.
- Rear center console.

NOTICE

Food, medication, and objects that are sensitive to heat or cold can become damaged or unusable from the air coming out of the vents.







- Do not place any food, medication, or other objects that are sensitive to temperature in front of the vents.

Air distribution functions in the Air conditioner menu: Classic Climate

 Set the blower speed with the touch control.  Direct air to the upper body.  Direct air into the footwell.  Direct air onto the windshield.

Air distribution functions in the Air conditioner menu: Smart Climate

If a Smart Climate function is switched on, Climatronic automatic mode is also switched on. The Smart Climate functions remain switched on for a short time and automatic mode also remains switched on once this time has elapsed.

 Clear fog and ice from the windshield.  Direct warm air into the footwell.  Direct warm air onto the steering wheel.  Direct cool air into the footwell.  Direct fresh air from outside into the vehicle interior.  Temporarily increase the power of the heating.  Temporarily increase the power of the refrigerant system.

Defrost function

On the control next to multi-function steering wheel

 The Climatronic defrost function clears fog and ice from the windshield.

The air is dehumidified and the blower is set to a higher speed.

Air recirculation

No fresh air will enter the vehicle interior when recirculation mode is switched on.

 Switch air recirculation on and off in the Air conditioner menu.

1. Open the Air conditioner menu in the Infotainment system.
2. Tap Classic Climate.
3. Tap .

When does recirculation mode switch off?

Recirculation mode will switch off in the following situations ⇒ :

- If the defrost function is switched on.
- If a sensor detects that the windows could fog up.

WARNING

Without a supply of fresh air, the door windows can mist up and reduce visibility, and the driver can quickly become fatigued from inhaling exhaled air. This can result in collisions, accidents and serious or fatal injuries.

- Only use recirculation mode for a short time.
- Switch off air recirculation as soon as it is no longer needed.

NOTICE

Cigarette smoke can settle on the air conditioner evaporator and the enhanced air filter and cause permanent odors.



- To prevent permanent odors, do not smoke inside the vehicle with air recirculation switched on.

Seat heating





When the vehicle's drive system is activated, the front seats and outer rear seats can be electrically heated in three levels.

 Switch the seat heating on and off in the Air conditioner menu.

Seat heating levels

The operation status of the seat heating is represented by colors in the Infotainment system. At the highest heating level, all three indicators under  or  in the Infotainment system are red.

Using the seat heating function

1. Open the Air conditioner menu in the Infotainment system ⇒ *Air conditioner menu in the Infotainment system*.
2. To switch on the seat heating at the highest heating level, tap  or  at the bottom edge of the screen.
3. To set the heating level, tap  or  repeatedly.

4. To switch the seat heating off, tap  or  repeatedly until the symbol is gray.

Or: to switch the seat heating on or off, tap with two fingers on the touch control under the Infotainment system on the driver's or passenger's side.

Switching on seat heating automatically at the beginning of the journey

1. Open the Air conditioner menu in the Infotainment system → *Air conditioner menu in the Infotainment system*.

2. To open the Climate control settings submenu, tap .

3. To select the heating level at the beginning of the journey, tap  in the Seat heating menu item.

After the vehicle's drive system has been activated, the selected heating level is automatically switched on, depending on the outside temperature.

Or: To stop seat heating being switched on automatically at the beginning of the journey, select Off in the menu item.

The seat heating switches on and off automatically

If you reactivate the vehicle's drive system within approximately ten minutes, the last heating level set for the driver seat is automatically switched on. If the front passenger seat is occupied, the last heating level set for the front passenger seat is also switched on automatically.

If the front passenger leaves their seat when the seat heating is switched on and the vehicle has been made drive-ready, the seat heating for the front passenger seat is automatically switched off. The display in the Infotainment system turns grey after approximately two seconds. If the front passenger takes their seat again when the vehicle is still drive-ready, the seat heating for the front passenger seat is automatically switched back on.

When should the seat heating function be switched off?

Switch off the seat heating function under any of the following conditions:

- The seat is occupied by a person with a limited perception of pain or temperature → .
- The seat is not occupied
- A child restraint is installed on the seat
- Objects are covering the seat, e.g. protective covers, jackets, blankets or bags.
- The seat is damp or wet.
- The interior or exterior temperature is higher than +25 °C (+77 °F).

WARNING

Magnetic fields are generated when the seat heating is operated. In individual cases, these magnetic fields can affect active medical implants (e.g. pacemakers).

- If you wear an active medical implant, you should consult your doctor or the manufacturer of your implant before operating the seat heating.
- Make your vehicle occupants aware of this as well.

WARNING

People who cannot feel pain or perceive temperature or can do so only to a limited extent, due to medication, paralysis or chronic illnesses such as diabetes, could develop burns or hypothermia on the back, buttocks and legs when using seat heating. Such injuries may take a very long time to heal or may never heal completely.

- Never use the seat heating function if you suffer from reduced perception of pain and/or temperature.
- Contact a medical doctor for questions about personal health conditions.

WARNING

If the seat cover is soaked through, this can cause the seat heating to malfunction and increase the risk of burns.

- Make sure the seat is dry before using the seat heating function.
- Never sit on the seat while wearing damp or wet clothing.
- Do not place any damp or wet objects and clothing on the seat.
- Do not pour any fluids on the seat.

NOTICE

Localized pressure and insulating materials can damage the heating elements of the seat heating.

- Do not kneel on the seats and do not exert any other form of localized pressure on the seat cushion and backrest.
- Do not exert pressure on the seat cushion and backrest with pointed objects.
- Switch off the seat heating if insulating materials have been fitted to the seat, e.g. a protective cover or a child restraint.

- Use the seat heating only when the seat is equipped with the original seat covers.
- If any odor starts to develop, turn off the seat heating immediately and have it checked by suitably qualified professionals. Volkswagen recommends contacting an authorized Volkswagen dealer or authorized Volkswagen Service Facility.

 In order to save energy, switch off the seat heating as soon as possible.

Steering wheel heating



The steering wheel heating only works when the vehicle's drive system is activated.

 **Switch the steering wheel heating on or off in the Infotainment system.**

Heating levels for the steering wheel heating

The steering wheel heating modes are shown by colors in the Infotainment system. At the highest heating level, all three indicators under  in the Infotainment system are red.

Operating steering wheel heating

1. Open the Air conditioner menu in the Infotainment system ⇒ [Air conditioner menu in the Infotainment system](#).
2. Open the Classic Climate submenu in the Infotainment system.
3. To switch on steering wheel heating at the highest heating level, tap .
4. To adjust the heating level, tap  repeatedly.
5. To switch the steering wheel heating off, tap  repeatedly until the symbol turns gray.

Steering wheel heating switches on automatically

If you reactivate the vehicle's drive system within approximately ten minutes, the last heating level set is automatically switched on.

Switching on steering wheel heating automatically at the beginning of the journey

1. Open the Air conditioner menu in the Infotainment system ⇒ [Air conditioner menu in the Infotainment system](#).
2. To open the Climate control settings submenu, tap .
3. Activate the Steering wheel heating checkbox.

After drive-ready mode is established, the steering wheel heating is automatically switched on, depending on the outside temperature.

Switching on Steering Wheel Heating automatically with the Smart Climate function

 **Direct warm air onto the steering wheel.**

The Smart Climate submenu is available depending on the vehicle equipment.

If you switch on the Smart Climate function  in the Air conditioner menu, the steering wheel heating will be switched on at the lowest heating level.

If the steering wheel heating is already switched on before switching on the Smart Climate function , the set heating level of the steering wheel heating remain selected.

Steering wheel heating switches off automatically

If one of the following conditions applies, the steering wheel heating switches off automatically:

- If the energy use is too high.
- If the steering wheel heating system is malfunctioning.

Windshield defroster

The windshield defroster only works when the vehicle's drive system is activated.

 **Switch the windshield defroster on and off on the control next to the multi-function steering wheel.**

FRONT

Depending on the outside temperature, the windshield defroster switches off automatically, at the latest after approximately eight minutes.

Defrosting the windshield using the defrost function

If the defrost function is switched on and a sensor detects that the windshield may fog up, the windshield defroster will turn on automatically.

The windshield defroster switches off automatically

If one of the following conditions applies, the windshield defroster switches off automatically:

- If the energy use is too high.
- If the climate control system is malfunctioning.
- If the specified time has expired.

Rear window defroster

The rear window defroster only works when the vehicle's drive system is activated.

 **Switch the rear window defroster on and off on the control next to the multi-function steering wheel.**
REAR

The rear window defroster switches off automatically after a maximum of around ten minutes.

NOTICE

Stickers applied over the heating wires of the rear window defroster on the inside can damage the rear window defroster.

- Do not affix stickers over the heating wires of the rear window defroster.

 In order to save energy, switch off the rear window defroster as soon as possible.

Stationary air conditioning

Introduction

The stationary air conditioning allows the vehicle interior to be cooled, ventilated or heated while stationary. In winter the windshield can be cleared of ice, fog, and a thin layer of snow. The stationary air conditioning is powered via a mains socket or by the vehicle high-voltage battery.

You can program and control the stationary air conditioning in the Infotainment system and using an app on your cell phone.

On the Internet you can find information about the app, about prerequisites for use and availability, as well as compatible end devices ⇒  [Introduction](#).

NOTICE

Food, medication, and objects that are sensitive to heat or cold can become damaged or unusable from the air coming out of the vents.

- Do not place any food, medication, or other objects that are sensitive to temperature in front of the vents.

 **If you use stationary air conditioning without a charging cable connected, the vehicle range will decrease. In extreme outside temperatures, the heating and cooling power of the stationary air conditioning function may not be sufficient to reach the preset desired temperature.**

Operating the stationary air conditioning



 **Please read the introductory information and heed the Warnings and Notice ⇒  [Introduction](#).**

The stationary air conditioning can be operated without a charging connector plugged in. If the charging connector is not connected, the stationary air conditioning is powered by the high-voltage battery.



If no charging connector is connected, stationary air conditioning only works when the high-voltage battery is sufficiently charged. Stationary air conditioning does not start if the Volkswagen Digital Cockpit is displaying the battery charge level of the high-voltage battery ⇒ [Charge status and range in the digital instrument cluster](#).

Opening the Stationary air conditioning menu in the Infotainment system

 **Stationary air conditioning menu in the Infotainment system.**

1. Tap the  home button.
2. Tap .

Setting your desired temperature

1. Open the Stationary air conditioning menu in the Infotainment system.
2. Tap .
3. Set a desired temperature using  and .

Activating the air conditioning in the stationary vehicle immediately

 **Activate immediate air conditioning in the exit menu in the Infotainment system.**

1. Set the electronic parking brake.
2. Release the driver seat belt buckle.

The exit menu is displayed in the Infotainment system.

3. In the exit menu in the Infotainment system, tap  ⇒ [Exit menu](#).

The air conditioning switches on for around 30 minutes. The function then switches off automatically.

Alternatively, the air conditioning can be activated in the vehicle before a preset departure time ⇒ [Programming the stationary air conditioning](#).

Switching off the stationary air conditioning manually

1. Set the electronic parking brake.
2. Release the driver seat belt buckle.

The exit menu is displayed in the Infotainment system.

3. Tap Immediate air conditioning in the exit menu in the Infotainment system.

Or: Tap  in the Air conditioner menu.

Or: Switch off stationary air conditioning via the app on the cell phone.

The stationary air conditioning switches off automatically

If one of the following conditions is met, the stationary air conditioning switches off automatically:

- After around 30 minutes, if the vehicle is air-conditioned with the ignition switched off.
- After around 15 minutes, if the vehicle is not drive-ready after a programmed departure time.
- If the charge level of the high-voltage battery is too low ⇒ [Departure Times \(time-delayed charging\)](#).

 **Operating noises can be heard when stationary air conditioning is switched on.**



Programming the stationary air conditioning

 **Please read the introductory information and heed the Warnings and Notice** ⇒  [Introduction](#).

With the Infotainment system, you can program stationary air conditioning for a planned departure time. You can program the preferred temperature for the vehicle interior at a certain departure time.

The vehicle calculates the time at which stationary air conditioning should be switched on, based on your desired temperature, in order to reach that temperature by the departure time. The maximum stationary air conditioning pre-running time is around 30 minutes before the departure time.

Activating the air conditioning in the vehicle before departure

1. Open the Stationary air conditioning menu.
2. Tap  to open the timer menu.
3. Set a scheduled departure time.
4. Tap .
5. Tap the checkbox to switch on the timer.

The earliest programmed departure time is displayed in the exit menu in the Infotainment system and can be switched on or off there ⇒ [Exit menu](#).

 **If the vehicle is locked, the stationary air conditioning can switch on a maximum of five consecutive times. This counter will be reset as soon as the vehicle is drive-ready.**

Stationary air conditioning with convenience functions

If the vehicle is being air-conditioned before departure, the vehicle can also switch on the convenience functions automatically depending on the outside temperature. The convenience functions will switch on automatically ten minutes before the scheduled departure time at the earliest.

The vehicle can automatically switch on the following convenience functions depending on the vehicle equipment before a scheduled departure time:

- Seat heating.
- Steering wheel heating.
- Exterior mirror heating.
- Rear window defroster.
- Windshield defroster.

To ensure that the vehicle switches on the convenience functions before a scheduled departure time, proceed as follows:

1. Open the Stationary air conditioning menu.
2. Tap .
3. Select the front seats for which the convenience functions are to be automatically switched on before the scheduled departure time.

Only the convenience functions of the selected front seats will be automatically switched on before the scheduled departure.

4. To ensure that the rear window defroster is automatically switched on before the departure time, for example, switch on the Window heating function.

Activating the air conditioning in the vehicle after charging the high-voltage battery

If the vehicle high-voltage battery is charged with alternating current (AC) or direct current (DC), then the air conditioning can be activated prior to a planned departure time. This setting can be applied in the charging settings in the Infotainment system ⇒ [Departure Times \(time-delayed charging\)](#).

Activating the air conditioning in the vehicle after unlocking

1. Open the Stationary air conditioning menu in the Infotainment system.
2. Tap .
3. Activate the Activate air conditioning in the vehicle after unlocking checkbox.

The air conditioner switches on for five minutes as soon as you open a vehicle door. The air conditioning does not start if you open a vehicle door and the vehicle is being charged with alternating current (AC) at that time.

 Depending on the vehicle equipment, in vehicles with Keyless Access, you can go to the Vehicle settings menu in the Infotainment system to set door unlocking to Single door or All doors ⇒ *Unlocking or locking using Keyless Access*. If door unlocking is set to Single door, the air conditioning will only start when you open the driver door. If door unlocking is set to All doors, the air conditioning will start as soon as you open a vehicle door or the trunk lid.

Checking the programming

When you switch off the ignition, the Infotainment system shows you the timer that has been set to act next and the functions that have been set.

Troubleshooting

or Atmospheric CO2 concentration in the vehicle interior is too high

The indicator light comes on yellow or red.

The message Health risk! High CO2 concentration. Open windows! or Health risk! CO2 too high. Open windows immediately! may appear in the instrument cluster display.

1. Open all windows immediately.
2. Contact an authorized Volkswagen dealer or authorized Volkswagen Service Facility to have the air conditioner checked. Volkswagen recommends contacting an authorized Volkswagen dealer or authorized Volkswagen Service Facility.

air conditioner is not working correctly or CO2 concentration cannot be measured

The yellow indicator light turns on.

The message Air conditioner is not working correctly. Please contact workshop. may appear in the instrument cluster display.

1. Contact an authorized Volkswagen dealer or authorized Volkswagen Service Facility to have the air conditioner checked. Volkswagen recommends contacting an authorized Volkswagen dealer or authorized Volkswagen Service Facility.

The cooling mode or heating cannot be switched on or the function is limited

The  cooling mode works as soon as the driver seat is occupied.

If the high-voltage battery is very warm, there are extreme outside temperatures or if the high-voltage battery charge level is too low, the function of the cooling mode , the heating and the defrost function may be limited.

- Switch on the fan.
- Charge the high-voltage battery to a sufficient level.
- Check the safeguard on the air conditioning system ⇒ *Replacing fuses*.
- Change active combination filters ⇒ *Service*.
- If the malfunction persists, contact a suitably qualified professional. Volkswagen recommends contacting an authorized Volkswagen dealer or authorized Volkswagen Service Facility.

NOTICE

Continuing to operate the air conditioner when it is not working can result in subsequent damage.

- If the air conditioner is not cooling or heating the air, switch it off immediately.
- Have the air conditioner checked by suitably qualified professionals. Volkswagen recommends contacting an authorized Volkswagen dealer or authorized Volkswagen Service Facility.

The windows are fogged up

The windows fog up when they are colder than the ambient temperature and the air is very humid. Cold air does not absorb as much moisture as warm air which is why windows fog up more frequently during cold seasons.

1. To improve the heating and cooling output, keep the air intake in front of the windshield free of ice, snow, and leaves ⇒ *Vehicle care*.
2. Leave the air duct in the rear section of the luggage compartment uncovered so that air can flow through the vehicle from front to back.
3. Switch on the defrost function ⇒ *Defrost function*.

The temperature unit has changed

You can change the temperature units for all temperature displays in the vehicle using the Infotainment system.

1. Tap the home button.
2. Open the Settings menu.
3. Select the Units menu item.

Water or water vapor under the vehicle

In the case of high outside humidity and temperatures, condensation can drip from the air conditioning system evaporator and pool under the vehicle. This is normal and does not mean there is a leak in the system.

When outside humidity is high and temperatures are low, condensation can evaporate when the auxiliary air conditioning is running. If this is the case, water vapor may escape under the vehicle. This does not indicate vehicle damage.

Stationary air conditioning cannot be switched on

If the stationary air conditioning runs for a long time when the charging connector is not connected, the high-voltage battery will drain. The stationary air conditioning does not start if the battery charge level of the high-voltage battery is not sufficient.

Noises when the stationary air conditioning is switched on

Operating noises when stationary air conditioning is switched on are normal and not an indication of a fault.

Controls are responding differently than expected

Moisture, dirt and grease may limit the functioning of the controls.

1. Always keep the control panels clean and dry.

Driving

Information on the drive

Functions of the electric drivetrain

Power output of the electric drivetrain

The maximum torque of the electric drivetrain is available the instant the accelerator pedal is pressed.

Brake energy recuperation

When you brake the vehicle, electrical energy is generated by the electric drivetrain and this is stored in the high-voltage battery ⇒ *Brake energy recuperation*. This happens also to a lesser extent when the vehicle is coasting or driving downhill.

The brake energy recuperation, and therefore also the engine braking effect, decreases as the charge level of the high-voltage battery increases. If the high-voltage battery is completely charged, there is no brake energy recuperation and no engine braking effect ⇒ ⚠.

The energy recuperation process can be displayed in the instrument cluster or on the screen of the Infotainment system.

Crawling feature

The crawling feature enables you to drive slowly forwards or in reverse at approximately 5 km/h (3 mph) without having to use the accelerator pedal.

The crawling feature is automatically active:

- If the vehicle's drive system is activated and a **D/B** gear is engaged.
Or: if the reverse gear **R** is engaged.

The crawling feature is deactivated:

- If the driving mode selector is in the **N** position.
Or: if the electronic parking brake **(P)** is switched on.

⚠ WARNING

An electric vehicle generates very little stationary, driving or operating noise. As a result, when your vehicle is being driven, other road users such as pedestrians and children may have difficulty hearing your vehicle or may not notice it at all in traffic-calmed zones and when maneuvering or reversing. This may cause accidents and serious injuries.

- Always bear in mind that other road users may not notice the driving noise.

⚠ WARNING

With a gear engaged, the vehicle could move unintentionally. This can cause accidents and serious injuries.

- When the vehicle is drive-ready and the **D/B** gear or **R** reverse gear is engaged, hold the vehicle stationary with the brake pedal.

⚠ WARNING

As the high-voltage battery charge level increases, the engine braking effect from brake energy recuperation decreases, and could fade away completely, leading to changed braking behavior. This can cause serious injuries.

- Before driving long distances on steep hills, reduce your speed.
- When driving long distances on steep hills, reduce your speed with the vehicle brakes.

Steering

Steering information

To make it more difficult to steal the vehicle, the steering must always be locked before leaving the vehicle.

Steering

Power steering on an electromechanical steering system adjusts automatically based on the driving speed, the steering torque, and the steering angle of the wheels. Electromechanical steering works only when the vehicle's drive system is activated.

If the power steering system is impaired or malfunctioning, a significantly greater amount of force than normal must be used to steer.

Electronic steering lock

The steering column is locked electronically:

1. Stop the vehicle.
2. Set the electronic parking brake.
3. If the ignition is active, press the starter button once.

Or: open the driver door, which will switch off the ignition. The steering column will be locked.

Countersteering assist

The counter-steering assistance provides the driver with power steering in some critical driving situations. Additional steering power, together with the ESC , supports the driver when counter-steering ⇒ .

WARNING

Power steering only works when the vehicle is ready to drive. If the power steering is not functioning, the steering wheel becomes stiff, making it much more difficult to steer. That can result in loss of control of the vehicle, accidents and serious or fatal injuries.

- Never let the vehicle roll when drive-ready mode has ended.

WARNING

The counter-steering assistance is not a replacement for the driver's attention and works only within the system limitations. In critical driving situations, uncontrolled vehicle movements can occur despite the counter-steering assistance. If you do not pay attention, there is a risk of accidents, serious injuries and death.

- Always stay attentive and do not rely solely on the system. The driver is always responsible for control of the vehicle.
- Ensure that the vehicle is not steered by the counter-steering assistance.
- Always adapt your speed and driving style to the visibility, weather, road and traffic conditions.

NOTICE

If the ignition is switched off when the vehicle is being towed, some vehicle functions are not available, such as the turn signals, horn, windshield wipers and the windshield washer system.

- Switch on the ignition when towing the vehicle.

Troubleshooting

Steering malfunction

The red warning light turns on or flashes.

There is an electromechanical steering or electronic steering lock malfunction.

Do not continue driving!

1. Contact an authorized Volkswagen dealer or authorized Volkswagen Service Facility for assistance.
 - If the red warning light turns on, it may be difficult to move the steering wheel because the electromechanical steering system is malfunctioning.
 - If the red warning light blinks, the steering column cannot unlock.
 - The vehicle may not be towed on its own four wheels.

Steering malfunction

The yellow indicator light turns on or flashes.

The steering is stiffer or more sensitive than usual.

The indicator light comes on permanently:

1. Re-activate the vehicle's drive system and slowly drive a short distance.
2. If the indicator light stays on, contact a suitably qualified professional and have the system checked. Volkswagen recommends contacting an authorized Volkswagen dealer or authorized Volkswagen Service Facility.

The indicator light blinks:

1. Turn the steering wheel back and forth slightly.
2. Switch the ignition off and back on.
3. Take note of messages in the ID. cockpit.
4. If the indicator light continues to flash after switching the ignition back on, do not continue driving. Contact an authorized Volkswagen dealer or authorized

Pedals

Information on the pedals



Fig. 83 In the footwell: pedals.

- ① Accelerator pedal.
- ② Brake pedal.

⚠ WARNING

Objects in the driver footwell can prevent the pedals from moving. This can cause the driver to lose control of the vehicle and increases the risk of serious or fatal injuries.

- Make sure all pedals can always be pressed without obstructions.
- Always attach floor mats securely in the footwell.
- Never place floor mats or other carpet over the installed floor mat.
- Make sure no objects can enter the driver footwell while driving.
- Remove any objects from the footwell when the vehicle is parked.
- Wear shoes that give your feet good grip for operating the pedals.

⚠ WARNING

Not paying attention to road traffic can cause accidents and serious or fatal injuries.

- Always comply with the applicable driving regulations and speed limits and think ahead while driving.
- Take regular breaks on long drives. You should take a break at least every two hours.

⚠ WARNING

Alcohol, drugs, medication, and prescription narcotics can considerably impair perception, reaction times, and driving safety, which can result in loss of vehicle control. This can cause accidents and serious or fatal injuries.

- Do not drive under the influence of alcohol, drugs, medication or prescription narcotics.

ⓘ NOTICE

If a brake circuit is malfunctioning, the brake pedal may need to travel farther in order to stop the vehicle. A longer braking distance may cause damage to the vehicle.

- Ensure that all the pedals can always be pressed without obstructions.
- Press the brake pedal down farther if braking power is reduced.

Brakes

Information on the brakes

Breaking in brake pads

During the first approx. 200 to 300 km (approx. 100 to 200 miles), new brake pads do not yet have their full braking efficiency and first need to be “worn in” ⇒ ⚠️. However, you can compensate for the slightly reduced braking force by pressing firmly on the brake pedal. During the break-in period, the braking distance during full braking or automatic braking is longer than with brake pads that have been broken in. During the break-in period, avoid full braking and situations that place a heavy load on the brakes, such as driving too close to the vehicle ahead.

Brake pad wear

Brake pad wear depends on driving conditions and style. When driving frequently in cities and on curves or with a sporty driving style, have your brake pads checked frequently by suitably qualified professionals. Volkswagen recommends contacting an authorized Volkswagen dealer or authorized Volkswagen Service Facility.

External influences on the brake

When driving with wet brakes, for example after driving through water, in heavy rain, or after washing your vehicle, the braking efficiency can be reduced by moisture or ice on the brake discs. You must “dry” the brakes as soon as possible by braking carefully at high speeds. The braking strength must be higher than can be delayed by recuperation to engage the brake pads. For these braking maneuvers, engage gear **N** so that energy recuperation is not used for braking. Ensure that you do not endanger any other vehicles or anyone else on the road ⇒ ⚠️.

A coating of salt on the brake discs and brake pads reduces the braking efficiency and increases the braking distance. If you do not apply the brakes for long periods of time on salt-covered roads, you must brake carefully to clean off the layer of salt ⇒ ⚠️. The braking strength must be higher than can be delayed by recuperation, to enable the layer of salt to be cleaned off by the engaged brake pads. For these braking maneuvers, engage gear **N** so that energy recuperation is not used for braking. Ensure that you do not endanger any other vehicles or anyone else on the road ⇒ ⚠️.

Leaving the vehicle parked for long periods of time, low mileage, and avoiding heavy braking can contribute to corrosion on the brake rotors and dirty brake pads. If you usually avoid heavy braking or if there is corrosion present, occasional heavy braking at high speeds is recommended to clean the brake rotors and pads. For these braking maneuvers, engage gear **N** so that energy recuperation is not used for braking. Ensure that you do not endanger any other vehicles or anyone else on the road ⇒ ⚠️.

⚠️ WARNING

Driving with worn brake pads or a malfunctioning brake system can lead to a loss of control of the vehicle, accidents and serious or fatal injuries.

- If you suspect that the brake pads are worn or the brake system is malfunctioning, immediately find a suitably qualified professional and have the brake pads checked and worn brake pads replaced. Volkswagen recommends contacting an authorized Volkswagen dealer or authorized Volkswagen Service Facility.

⚠️ WARNING

Up to the first approx. 300 km (approx. 200 miles), new brake pads do not yet have their full braking efficiency and first need to be “worn in”. Insufficient braking efficiency can increase the risk of accidents. This can cause serious or even fatal injuries.

- Increase the pressure on the brake pedal if reduced braking efficiency can be felt.
- To reduce the risk of accidents, serious injuries, and loss of vehicle control, drive with extra caution when the brake pads are new.
- During the break-in period for new brake pads, do not drive too close to other vehicles and avoid driving situations that place a heavy load on the brakes.

⚠️ WARNING

Prolonged braking causes the brakes to overheat. This can considerably reduce braking performance, increase braking distance and possibly cause a total brake system malfunction. This can cause a loss of vehicle control, accidents, and serious or fatal injuries.

- Never let the brakes “rub” too often and too long or press the brake pedal too often and too long.

⚠️ WARNING

When driving downhill, a lot of force is placed on the brakes and they become hot quickly. Overheated brakes reduces the braking efficiency and increase the braking distance considerably. This can cause loss of vehicle control, accidents, and serious or fatal injuries.

- Before driving on a long stretch of road with a steep gradient, reduce your speed and select a higher energy recuperation level. This utilizes the braking effect of the electric drivetrain and reduces the load on the brakes.
- Before starting a journey, ensure that the air supply to the brakes is not covered, e.g. by aftermarket or damaged front spoilers.

⚠️ WARNING

Wet, icy, or salt-covered brakes will take longer to brake and increase the braking distance. This can cause a loss of vehicle control, accidents, and serious or

fatal injuries.

- Test the brakes carefully.
- Press the brake pedal carefully several times to dry the brakes and clear the ice and salt from them, as long as the visibility, weather, road, and traffic conditions permit.

 **Regularly check the thickness of the front brake pads visually by inspecting them through the openings in the wheel rims or from underneath the vehicle. If necessary, remove the wheels so that the brake pads can be inspected. Volkswagen recommends contacting an authorized Volkswagen dealer or authorized Volkswagen Service Facility.**

 **If you are having the front brake pads checked, the brake pads in the drum brake on the rear axle should be checked at the same time. The check is performed through an eyehole on the rear side of the drum. To do this, you must remove a sealing plug. Volkswagen recommends contacting an authorized Volkswagen dealer or authorized Volkswagen Service Facility.**

Troubleshooting

BRAKE Brake system malfunction

The red warning light turns on. A message may also be displayed.

1.  **Do not continue driving!** Contact an authorized Volkswagen dealer or authorized Volkswagen Service Facility immediately for assistance.

BRAKE WEAR Brake pad wear indicator

The red warning light turns on or flashes.

The front brake pads are worn.

1. Immediately contact an authorized Volkswagen dealer or authorized Volkswagen Service Facility to have the system checked. Volkswagen recommends contacting an authorized Volkswagen dealer or authorized Volkswagen Service Facility.
2. Have all brake pads inspected and replaced, if necessary.

and **The brake is too hot**

The yellow indicator light turns on.

An audible warning may also sound. Where applicable, a message will appear in the instrument cluster display.

1. Stop at the next opportunity.
2. Leave the vehicle with the electronic parking brake applied and the ignition switched on until a further message appears.
3. Then get professional assistance to have the system inspected. Volkswagen recommends contacting an authorized Volkswagen dealer or authorized Volkswagen Service Facility.

Unusual noises when braking

If there are sustained scraping or squeaking noises when braking, that is a sign of worn brake pads on the front or rear axle.

1. Immediately contact an authorized Volkswagen dealer or authorized Volkswagen Service Facility to have the system checked. Volkswagen recommends contacting an authorized Volkswagen dealer or authorized Volkswagen Service Facility.
2. Have all brake pads inspected and replaced, if necessary.

If the vehicle's braking performance changes

If the brake pads are worn or if you notice that your vehicle does not brake as usual, e.g. the braking distance suddenly increases:

1. Immediately contact an authorized Volkswagen dealer or authorized Volkswagen Service Facility to have the system checked. Volkswagen recommends contacting an authorized Volkswagen dealer or authorized Volkswagen Service Facility.
2. Have all brake pads inspected and replaced, if necessary.

Activating the vehicle's drive system

Switching the ignition on and off

Some vehicle functions are activated as soon as the driver approaches the vehicle with the vehicle key.

Switching on the ignition

1. Press the starter button once. The starter button is on the right-hand side of the steering column.

Or: Press the brake pedal.

Switching off the ignition

1. If the ignition is active and the vehicle is stationary, press the starter button once.

Or: with the vehicle stationary and the electronic parking brake activated, leave the vehicle.

The ignition is also switched off if the vehicle is stationary and the brake is not pressed and the driver opens the driver seat belt buckle with the electronic parking brake switched on.

Automatic ignition switch off

If the driver moves away from the vehicle with the vehicle key when the ignition is switched on, the ignition will switch itself off automatically after a certain time. If the hood is opened while the ignition is switched on, the ignition does not switch off automatically.

If no valid remote control vehicle key is detected in the vehicle interior after the ignition has been switched off, the vehicle's drive system cannot be activated again without a valid vehicle key. A corresponding message is shown in the ID. cockpit.

WARNING

If the driving mode selector is moved when the ignition is switched on, the vehicle's drive system is activated immediately under certain conditions. This can cause unintentional vehicle movement and serious injuries.

- Do not operate the driving mode selector when switching on the ignition if drive-ready mode is not intended to be active.

WARNING

If you leave vehicle keys unattended in the vehicle, children or unauthorized people could lock the doors and/or the trunk lid, activate drive-ready mode, or switch on the ignition and thereby activate electrical equipment, such as the power windows. This can cause accidents and serious or fatal injuries.

- Always take all vehicle keys with you when leaving the vehicle.

WARNING

If you leave children, people requiring assistance or animals unattended in the vehicle, they may accidentally set the vehicle in motion or be subjected to very high or low temperatures. There is a risk of accidents and serious or fatal injuries.

- Never leave children, people requiring assistance or animals unattended in the vehicle.

 **The ignition can only switch on and the vehicle's drive system can only be activated if there is a valid vehicle key in the vehicle.**

Electronic immobilizer

The immobilizer helps prevent drive-ready mode from being established and the vehicle from being moved with an unauthorized vehicle key.

For vehicles with a starter button: In the remote control vehicle key, there is a chip used to automatically deactivate the electronic immobilizer when there is a valid remote control vehicle key in the vehicle interior.

For vehicles with a starter button: The electronic immobilizer is automatically activated as soon as there is no valid vehicle key in the vehicle.

Drive-ready mode can only be established with a Volkswagen Genuine vehicle key that is coded correctly. You can obtain coded vehicle keys from an authorized Volkswagen dealer or authorized Volkswagen Service Facility.

 **Only using Volkswagen Genuine vehicle keys will ensure that your vehicle operates correctly.**

Activating the vehicle's drive system

Prerequisites for activating the vehicle's drive system

If the following conditions are met, the vehicle's drive system can be activated:

- ✓ The high-voltage battery has a sufficient charge level.
- ✓ The vehicle is not connected to a charging cable.
- ✓ The high-voltage battery temperature is within the operating range.
- ✓ A valid remote control vehicle key is present in the vehicle.

Activating the vehicle's drive system

1. With the brake pedal pressed, engage selector lever position. A visual and audible signal tells you when the vehicle's drive system is ready for use.
2. If the vehicle's drive system cannot be activated, repeat the process. Perform an emergency start if necessary.

WARNING

An electric vehicle generates very little stationary, driving or operating noise. As a result, when your vehicle is being driven, other road users such as pedestrians and children may have difficulty hearing your vehicle or may not notice it at all in traffic-calmed zones and when maneuvering or reversing. This may cause accidents and serious injuries.

- Always bear in mind that other road users may not notice the driving noise.

Electronic engine sound

The electronic engine sound warns other road users of an approaching electric vehicle.

After activating the vehicle's drive system, the electronic engine sound is switched on.

When driving faster, the electronic engine sound will fade out slowly.

⚠ WARNING

The electronic engine sound may be quieter and/or more difficult to hear if there is snow around the front grille or if the area is very dirty. If the sound of the vehicle is not heard by other road users, this can lead to accidents and serious injuries.

- Before starting a journey, check the area around the front grille for heavy dirt and clean it if necessary.
- You should always assume that your vehicle will not be heard by other road users.

Exiting a vehicle while the vehicle's drive system is active

The ignition and the drive switch off automatically under certain conditions if the vehicle is exited after stopping with the drive system active and with a selector position engaged ⇒ *Switching the ignition on and off*.

This prevents unauthorized use of the vehicle.

Before you leave the vehicle, you must secure it against rolling away ⇒ *Electronic parking brake*.

If you need to drive again immediately afterwards, the ignition must be switched back on, for example by pressing the brake pedal, and the vehicle's drive system must be reactivated. If necessary, pay attention to the messages in the ID. cockpit.

⚠ WARNING

An unattended vehicle which is ready to drive can move unintentionally. This can cause accidents and serious injuries.

- Never leave a vehicle which is ready to drive unattended.
- Before leaving the vehicle, make sure that the electromechanical parking brake (Ⓢ) is switched on.
- When leaving the vehicle, always make sure that all doors, windows, the trunk lid and the hood are closed completely and locked.

Troubleshooting

Valid vehicle key cannot be detected



Fig. 84 In the center armrest: Emergency start function.

A corresponding indicator appears in the ID. cockpit.

If the vehicle key has a weak or drained button cell battery, the vehicle key may not be able to be detected.

An emergency start must be performed:

1. Place the remote control vehicle key in the cup holder or storage compartment in the center console *fig. 84*.
2. Press the brake pedal or the starter button. The ignition is switched on.

Vehicle's drive system cannot be connected.

If an unauthorized remote control vehicle key is used or the system is malfunctioning, a corresponding indicator appears in the ID. cockpit.

1. Use an authorized vehicle key.
2. If the malfunction persists, contact an authorized Volkswagen dealer or authorized Volkswagen Service Facility.

Deactivating the vehicle's drive system

Deactivating the vehicle's drive system

Only perform these steps in the specified order:

1. Bring the vehicle to a stop.
2. Park the vehicle.
3. Set the electronic parking brake.
4. Pay attention to the messages in the ID. Cockpit.

⚠ WARNING

An unattended vehicle which is ready to drive can move unintentionally. This can cause accidents and serious injuries.

- Never leave a vehicle which is ready to drive unattended.
- Before leaving the vehicle, make sure that the electromechanical parking brake (P) is switched on.
- When leaving the vehicle, always make sure that all doors, windows, the trunk lid and the hood are closed completely and locked.

Troubleshooting

The vehicle's drive system cannot be deactivated

The vehicle's drive system cannot be deactivated.

An emergency stop must be performed:

1. Bring the vehicle to a stop.
2. Press the starter button twice within several seconds or press and hold one time.

The vehicle's drive system is deactivated and the ignition is switched off.

Gear selection

Driving mode selector



Fig. 85 Driving mode selector with the button for the electronic parking brake (arrow).

The vehicle has a forwards gear **D/B** and a reverse gear **R**.

The driving mode selector has a button  for the electronic parking brake.

To change into gear from neutral position **N**, proceed as follows:

1. Switch the ignition on.
2. Press the brake pedal.
3. Turn the driving mode selector in the desired direction *fig. 85*.

List of selector lever positions

D Permanent position for driving forwards – the electric drivetrain is in the normal program. **B** Powerful energy recuperation when coasting ⇒ *Brake energy recuperation*. **Δ** To change between gears **D** and **B**, turn the driving mode selector forward once out of position **D/B** *fig. 85*. The driving mode selector always springs back. Turning it forward again switches back to gear **D**. **Ⓢ** The drive gears are mechanically locked. Only switch on when the vehicle is stationary ⇒ *Electronic parking brake*. **N** The electric drivetrain is in neutral position. No power is transmitted to the wheels and the braking effect of the electric drivetrain is not available. **R** Reverse gear is selected. Only select this gear when the vehicle is stationary.

Driving on an incline

When driving on an incline, energy recuperation should be used where possible ⇒ *Brake energy recuperation*.

Stopping and starting to drive uphill

Auto Hold should be used when stopping or starting uphill with the vehicle's drive system activated ⇒ *Auto Hold*.

If you stop on a hill with a gear selected, always press the brake pedal or set the electronic parking brake to prevent the vehicle from rolling away. Only release the brake pedal when you are pulling away.

Crawling feature

If the brake pedal is released when the Auto Hold function is switched off and the gear engaged, the vehicle will start "crawling", depending on the vehicle load even on very large hills. This allows the vehicle to be started through gentle braking more slowly and more precisely, e.g. when maneuvering.

WARNING

Engaging the incorrect gear can cause you to lose control of the vehicle, which could lead to accidents and serious injuries.

- Never press the accelerator pedal when engaging a gear.

WARNING

Fast acceleration or switching off the ASR can cause traction loss and sliding on slippery roads, such as on wet, icy or dirty roads. This could cause loss of vehicle control, accidents and serious or fatal injuries.

- Only use the kick-down function or accelerate quickly when the visibility, weather, road, and traffic conditions allow it, and when other road users will not be endangered by the vehicle's acceleration and driving style.
- Always adapt your driving style to the flow of traffic.

WARNING

An unattended vehicle which is ready to drive may cause accidents and severe injuries.

- Never leave a vehicle which is ready to drive unattended.
- Always switch the ignition off.
- When parking or leaving the vehicle, always ensure that the electronic parking brake is switched on.
- When leaving the vehicle, always make sure that all doors, windows, the trunk lid and the hood are closed completely and locked.
- When the vehicle is drive-ready and the **D/B** or **R** gear is engaged, hold the vehicle stationary with the brake pedal.
- Never shift into reverse gear while the vehicle is moving.

NOTICE

Incorrect handling of the electric drivetrain can lead to increased wear or damage.

- Never let the vehicle roll in the **N** gear, especially when the vehicle's drive system has not been activated.
- If you stop on inclines when a gear is engaged, use the brake pedal and not the accelerator to hold the vehicle.

Troubleshooting

Electric drivetrain overheated

The red warning light turns on.

The electric drivetrain has become overheated.

A corresponding message is shown in the ID. cockpit.

Do not continue driving!

1. Park your vehicle outside as soon as it is possible and safe to do so.
2. End drive-ready mode.
Do not add engine coolant.
3. Contact an authorized Volkswagen dealer or authorized Volkswagen Service Facility for assistance.

and ABS Brake energy recuperation not possible

The yellow indicator lights turn on.

Brake energy recuperation is malfunctioning.

This may limit your vehicle's range.

1. Contact an authorized Volkswagen dealer or authorized Volkswagen Service Facility to have the system inspected. Volkswagen recommends contacting an authorized Volkswagen dealer or authorized Volkswagen Service Facility.

NOTICE

If you allow the vehicle to roll for a long time or at high speeds when the ignition is off, the electric drivetrain is switched off or the 12 V vehicle battery is discharged, the electric drivetrain will become damaged.

- Note that the vehicle can only be towed under certain conditions ⇒ [Towing](#).

Drive will be immediately turned off

The high-voltage battery charge level is very low and the drive power reduced.

The red indicator light comes on when driving.

A message is displayed in the instrument cluster and an acoustic warning sounds.

The vehicle is about to be stranded in traffic.

Two emergency starts are still possible and the vehicle can still be moved a short distance at approx. 7 km/h (approx. 4 mph).

Climate control convenience functions are restricted.

1. If traffic conditions allow it, pull over and park the vehicle safely, or, if possible, drive to a charging station.

When the power increases again, the indicator light turns off.

Driving not possible

The temperature of the high-voltage battery is too low.

The red indicator light turns on before you start driving.

A message is displayed in the instrument cluster and an acoustic warning sounds.

A very low driving power can cause you to become stranded in traffic.

Only maneuvering at approx. 7 km/h (approx. 4 mph) is possible.

Climate control convenience functions are restricted.

- Charge the high-voltage battery when the charge status is low.
- If you intend to drive in cold weather, Volkswagen recommends activating the vehicle's climate control in advance, before departure. This also heats up the high-voltage battery, increasing its driving power available as soon as the vehicle is drive-ready.

Take note of the power display in the instrument cluster.

When the power increases again, the indicator light turns off.

Limited driving power

The yellow indicator light turns on.

A message is displayed in the instrument cluster and an acoustic warning sounds.

The driving power is reduced considerably and could reduce further.

Climate control convenience functions are restricted.

1. Charge the high-voltage battery when the charge status is low.

In extremely cold or hot outside temperatures, the high-voltage battery is heated or cooled while driving. The driving power increases again after a short time.

Take note of the power display in the instrument cluster.

When the power increases again, the indicator light turns off.

All-wheel drive (4MOTION) is restricted

There is a malfunction in the all-wheel drive (4MOTION). The driving performance has been restricted.

- In the ID. cockpit, the text message All-wheel drive (4MOTION) is restricted. Please adapt your driving behavior appears.
- It is possible to continue driving with reduced driving performance.

Have the vehicle checked immediately by a suitably qualified professional. Volkswagen recommends contacting an authorized Volkswagen dealer or authorized Volkswagen Service Facility.

All-wheel drive (4MOTION) is currently restricted

The front engine's driving performance has been restricted in order to avoid overheating.

- In the ID. cockpit, the text message All-wheel drive (4MOTION) is currently restricted. Please adapt your driving behavior appears.
- It is possible to continue driving with reduced driving performance.

The driving performance limitation is removed in the following scenario:

- The front engine is no longer within a critical temperature range.

Electronic engine sound failed

The yellow indicator light comes on and an audible signal sounds.

A corresponding message is shown in the ID. cockpit.

1. Contact an authorized Volkswagen dealer or authorized Volkswagen Service Facility to have the system inspected. Volkswagen recommends contacting an authorized Volkswagen dealer or authorized Volkswagen Service Facility.

It is possible to continue driving.

Brake energy recuperation

Brake energy recuperation

When slowing down the vehicle, and when the vehicle is rolling in overrun or driving downhill, electrical energy is created by the electric drivetrain and stored in the high-voltage battery. The electric drivetrain hereby works as a generator and creates an engine braking effect. This process is called "brake energy recuperation".

Engine braking varies depending on the selector lever position.

The vehicle brake light may light up when the brake energy recuperation is intense. The brake energy recuperation, and therefore also the engine braking effect, decreases as the charge level of the high-voltage battery increases. If the high-voltage battery is completely charged, there is no brake energy recuperation and no electric motor braking effect. If the vehicle detects that the road conditions do not permit safe contact between the wheels and the road, the energy recuperation, and therefore also the engine braking, is automatically reduced. The power display gives information about the available energy recuperation and the engine braking.

Depending on the selector lever position and the settings in the Infotainment system, the vehicle will recuperate differently:

Selector lever position **D** engaged and ECO assist deactivated: No energy recuperation.

Selector lever position **D** engaged and ECO assist activated: Automatic energy recuperation. The level of recuperation is automatically chosen depending on the navigation data and traffic situation.

Selector lever position **B** engaged: Intense energy recuperation.

The vehicle still recuperates energy if the brake pedal is pressed.

Eco assist

The ECO assist helps the driver use the vehicle's engine braking efficiently. It chooses the level of recuperation depending on the navigation data and the traffic situation.

The ECO assist can be switched on and off in the vehicle settings in the Infotainment system.

Driving on an incline

On inclines, it is best to drive in the **B** gear where possible.

Never let the vehicle roll down mountains or hills in the **N** neutral setting.

WARNING

Strong recuperation can cause traction loss and sliding, especially on slippery roads. This could cause loss of vehicle control, accidents and serious or fatal injuries.

- Only activate permanent high brake energy recuperation when the visibility, weather, road and traffic conditions allow and other road users are not put at risk by the vehicle deceleration and driving style.

WARNING

As the charge level of the high-voltage battery increases, the electric motor braking effect decreases and can completely disappear. The driving behavior may therefore change, which can cause accidents and serious or fatal injuries.

- Never completely charge the high-voltage battery at higher altitudes, for example on a mountain pass, in order to achieve braking efficiency thanks to brake energy recuperation on the subsequent drive down.
- Before driving on steep hills, reduce your speed.
- When driving on steep hills, reduce your speed with the vehicle brakes.
- Note that, in the absence of electric motor braking, the strain on the vehicle brakes increases.

Messages about driving

General driver information

Anticipatory driving

An inconsistent driving style increases consumption. When the driver actively pays attention to traffic, this can prevent frequent acceleration and braking maneuvers. Maintaining enough distance to the vehicle driving ahead helps you to drive with better anticipation.

Avoiding full acceleration

Excessively high speeds increase the rolling resistance and air resistance and with that, the power needed to move the vehicle. Never drive at the maximum vehicle speed.

Checking tire pressures

Low tire pressures cause wear as well as increased rolling resistance of tires, and this increases consumption. Use tires with optimal rolling resistance.

Adapt the tire pressures to the load:

- Follow the specifications on the tire pressure label ⇒ [Checking the tire pressure](#).
- Tire Pressure Monitoring System ⇒ [How the Tire Pressure Monitoring System Works](#).

WARNING

If you drive at high speed and without sufficient safety distance, accidents and serious or fatal injuries can result.

- Always adapt your speed and remain a safe distance to vehicles driving ahead according to the visual, weather, road, and traffic conditions.

Eco tips

The correct driving style can help to reduce consumption, pollution, and wear on the electric drivetrain, brakes, and tires. The following tips will help you conserve the environment and your money.

Using brake energy recuperation

If Eco assist is deactivated in the Infotainment system and gear **D** is engaged and the accelerator pedal is not pressed, the vehicle will “coast”.

If Eco assist is activated in the Infotainment system and gear **D** is engaged and the accelerator pedal is not pressed, the vehicle recuperates energy automatically. also adjusts to the current driving situation and external conditions such as the vehicle in front and speed limits. The energy from the rolling vehicle is also used to charge the high-voltage battery. The vehicle's brakes are also applied.

In gear **B**, if the accelerator pedal is not pressed, strong recuperation will occur.

Furthermore, the energy recuperation increases when the brake pedal is pressed.

Have maintenance performed regularly

Regular maintenance is required for fuel-efficient driving and increases the service life of the vehicle.

Removing unnecessary weight

Emptying out the luggage compartment before a journey, for example, removing empty crates or unneeded child restraints, can reduce energy consumption.

To keep the vehicle air resistance as low as possible, remove accessories such as ski, bicycle, and roof racks after use.

Saving power

Electrical equipment, such as the air conditioning system and window heating, requires energy from the high-voltage battery.

If you want to increase your vehicle's fuel range:

- Set a higher interior temperature in summer and a lower interior temperature in winter. When outside temperatures are high, air out the vehicle before driving.
- If you are using an external power supply, use the stationary air conditioning.
- Switch off comfort consumers that are not required.

 An authorized Volkswagen dealer or authorized Volkswagen Service Facility can provide you with more information about correct maintenance and replacement parts that are particularly energy efficient, such as new tires.

Driving a loaded vehicle

Heed the following for good vehicle handling when the vehicle is loaded:

- Stow all cargo securely ⇒ *Transporting*.
- Accelerate with extra care and caution.
- Avoid sudden braking and driving maneuvers.
- Brake earlier than usual.
- If necessary, read and heed the information about roof racks ⇒ *Roof rack*.
- If necessary, note the information about driving with a trailer ⇒ *Trailer towing*.

WARNING

Sliding loads can considerably impair the driving stability and safety of your vehicle, and increase the braking distance when you brake hard or perform emergency braking. This can cause accidents and serious or fatal injuries.

- Correctly secure the load to prevent it from sliding.
- Use suitable tie-downs or securing straps on heavy objects.
- Engage the rear seat backrests and, if necessary, the adjustable rear seats securely.

NOTICE

Spilled fluids can come in contact with the connectors of the orange high-voltage cables. This can cause damage to the electrical system and high-voltage battery.

- Do not transport large amounts of fluids in the vehicle interior.

Driving with an open trunk lid

Driving with an open trunk lid can be especially dangerous. Secure all objects and the open trunk lid correctly and take sufficient precautions.

Driving with an open trunk lid increases the air resistance of the vehicle and, consequently, the energy consumption of the electric drivetrain. This reduces the potential vehicle range significantly. Volkswagen recommends that you do not drive with the trunk lid open.

WARNING

If driving with the trunk lid unlocked or open, loose objects can fall out of the vehicle and injure other road users. This can cause accidents and serious or fatal injuries.

- Always drive with the trunk lid closed.
- Store all objects in the luggage compartment securely.
- Always drive carefully and anticipate upcoming traffic situations.
- Avoid abrupt or sudden driving and braking maneuvers because the open trunk lid can move in an uncontrolled manner.
- If there is a roof rack with cargo on the trunk lid, always remove it before driving with an open trunk lid.

WARNING

Objects protruding from the luggage compartment change the vehicle length and may possibly endanger other road users. This can cause accidents and serious or fatal injuries.

- Follow the legal regulations.
- Mark objects sticking out of the luggage compartment so they will be visible to others on the road.
- Never use the trunk lid to secure or wedge objects.

NOTICE

Opening the trunk lid changes the height and possibly the length of the vehicle. This can cause damage to the vehicle if driving carelessly.

- Be aware of the changed outer dimensions, such as when driving through underpasses.

Driving through water on roads

Note the following to reduce the risk of vehicle damage when driving through water, for example on flooded roads:

- The water must not be any higher than the bottom of the vehicle body ⇒ .
- Do not drive faster than walking speeds.
- Never stop the vehicle, drive in reverse, or deactivate the vehicle's drive system in water.
- Oncoming vehicles create waves that can raise the water level for your vehicle enough that it is not safe to drive through.

WARNING

When driving through water, mud, slush, etc., the braking effect may be delayed due to damp or icy brake rotors and brake pads in the winter, and this can extend the braking distance. This could cause a loss of vehicle control, accidents and serious or fatal injuries.

- Perform careful braking maneuvers to dry and remove ice from the brakes.
- Do not endanger road users or disregard legal regulations during braking maneuvers.
- Avoid abrupt and sudden braking maneuvers directly after driving through water.

NOTICE

Driving through water can greatly damage or corrode parts of the vehicle, e.g. electronics.

- Never drive through salty water.
- Using fresh water, immediately rinse any parts of the vehicle that may have come into contact with salty water.
- Protect electronic components against contact with water.

Operating the vehicle in different countries and continents

Approval regulations

The vehicle was manufactured by the factory for a specific country and meets those requirements and approval regulations that were valid at the time of vehicle manufacture.

 **If the vehicle will be used temporarily or for a brief period in another country, then read and observe the following information.**

Safety standards and regulations

Some countries have special safety standards and regulations that differ from the vehicle configuration. Volkswagen recommends obtaining information about legal regulations from an authorized Volkswagen dealer or authorized Volkswagen Service Facility before driving in other countries.

Selling in other countries

If the vehicle is sold in another country or will be used for an extended period in another country, then the applicable legal regulations in that country must be observed.

Certain equipment may need to be installed or removed and functions may need to be deactivated. The scope and types of service may also be affected. This particularly applies if the vehicle is being operated for an extended period in a different climate region.

Functions of the Infotainment system

Due to the many different frequency bands around the world, the Infotainment system installed at the factory may not function in other countries.

Charging in other countries

Due to the various different legal regulations, you may only be able to charge with limited charging current at power outlets in other countries. The charging cable limits the charging current depending on the infrastructure used. If there are different settings, the lower value is used for charging ⇒ [Charging cable](#).

Due to the different technical standards, you may not be able to charge at charging stations in another country or only if you use a suitable charging cable. For more information contact an authorized Volkswagen dealer or authorized Volkswagen Service Facility.

 Volkswagen is not responsible for damage to the vehicle caused by insufficient maintenance or a lack of available original parts.

 Volkswagen is not responsible if the vehicle does not meet all of the applicable legal requirements in other countries and continents.

Driving Mode Selection

Introduction

Via the driving modes, the driver can adapt various properties of vehicle systems to the current driving situation, the desired driving comfort, and for an economic driving style. The suspension, steering, drive, and the air conditioner are some of the vehicle systems that can be adjusted.

Different driving modes are available depending on the vehicle equipment. The influence of vehicle systems on the individual driving modes depends on the vehicle equipment.

Selecting the driving mode

The driving mode can be selected when the ignition is switched on and the vehicle is stationary or while driving.

WARNING

Setting the driving mode while driving can distract from traffic. This can cause accidents and serious or fatal injuries.

- Always drive attentively and responsibly.

If you select a driving mode while driving, the vehicle systems, except for Drive, will be switched over to the new driving mode immediately.

1. When the traffic situation allows it, briefly take your foot off the accelerator pedal to enable the newly selected driving mode to be applied to the Drive vehicle system as well.



Selecting a driving mode via the control on the Infotainment system

1. Tap .
2. To select driving modes, tap  again or tap the desired driving mode in the Infotainment system.





Displaying information about the driving mode

1. To display additional information about the selected driving mode, tap  in the Infotainment system.

Selecting the Custom driving mode

1. Tap  until the Custom driving mode has been selected.
2. Tap  to open the Custom menu.

Driving mode properties

 The Eco driving mode switches the vehicle to fuel-efficient operation and supports the driver with an energy-saving driving style.  The Comfort driving mode is the basic setting for the vehicle systems, provides a comfort-oriented vehicle setup and is suited, for instance, for everyday use.  The Sport driving mode gives the driver a sporty feel.  The Traction driving mode offers maximum all-wheel drive (4MOTION) support and softens the suspension damping.

On loose ground, it provides better traction.

The Traction driving mode is available only for vehicles with all-wheel drive (4MOTION).

 With the Custom driving mode, you can adapt individual vehicle systems according to your preferences.

Standard behavior of the driving mode and the vehicle systems

The Comfort driving mode shows the basic settings of the vehicle systems when the ignition is switched on.

Behavior of the driving mode when switching the ignition off and on

When you switch the ignition off and back on again, the previously selected driving mode remains active.

Behavior of the Drive vehicle system when the ignition is switched off and on

The Drive vehicle system settings are reset to the Comfort driving mode settings when you switch the ignition off and on again.

The other vehicle systems will retain their settings.

You can change the Drive vehicle system back to the preferred driving mode.

1. Select your desired driving mode again.

Troubleshooting

The driving mode or the vehicle systems do not behave as expected

1. Pay attention to the standard behavior of the driving mode and the vehicle systems ⇒ *Standard behavior of the driving mode and the vehicle systems*.

Driver assistance systems

Sensor system information

Introduction

Depending on the vehicle equipment, the vehicle has driver assistance systems that increase driving convenience. These driver assistance systems use some sensors and cameras (hereafter referred to as the "sensor system") that are only partially visible to you.

The sensors and cameras visually detect the vehicle's surroundings ultrasonically or by using radar waves.

Installed sensor systems

Depending on the vehicle equipment, the following sensor systems may be installed:

- Radar sensor in the front of the vehicle.
- Radar sensors in the rear of the vehicle.
- Camera behind the windshield.
- Ultrasonic sensors in the front of the vehicle.
- Ultrasonic sensors in the rear of the vehicle.



 You can find information on the relevant installation location in the vehicle overviews ⇒ [Vehicle overviews](#).

WARNING

The driver assistance systems are not a replacement for the driver's attention and work only within their system limitations. The driver assistance systems cannot detect all driving situations and may not provide warnings or react, or may provide warnings or react with a delay, or may provide warnings or react in a way that is not desired. If you are careless, there is a risk of accidents, serious injuries and death.

- Always stay attentive and do not rely solely on the system. The driver is always responsible for control of the vehicle.
- Be aware of the limits of the sensor system and the system limitations of the individual systems.
- Always adapt your speed and distance to vehicles driving ahead based on the visual, weather, road, and traffic conditions.
- Be prepared to override or interrupt automatic interventions at all times.
- Pay attention to indicators in the instrument cluster display and respond to the displays accordingly when the traffic situation allows.
- Do not use driver assistance systems if you suspect a problem or damage.

Limits of the sensor system

 Please read the introductory information and heed the Warnings and Notice ⇒  [Introduction](#).

Limits of the radar sensor

Driver assistance systems that use radar sensors may not respond, may offer a delayed response or may respond in an unexpected way in the following situations

- When driving in poor weather conditions, such as heavy rain, snow or heavy spray.
- When driving through construction zones, tunnels or toll stations.
- When driving on winding roads, for example, mountain roads
- In front of bumps or dips in the road
- When driving off-road
- When driving in parking ramps
- When driving on roads with embedded metal objects, such as railroad tracks
- When driving on gravel roads
- In complex driving situations, such as traffic islands.
- Following a violent impact affecting components within the range of the radar sensors, e.g. following a rear-end collision.
- If the radar sensors are obscured, dirty, misaligned or damaged.

Limits of the camera behind the windshield

Driver assistance systems that use the camera behind the windshield may not respond, may offer a delayed response or may respond in an unexpected way in the following situations:

- In front of bumps or dips in the road
- When driving in construction zones
- When driving off-road
- When driving in poor weather conditions, such as heavy rain, snow, fog or heavy spray and poor road conditions.
- In low-lying sun, darkness or if there is glare from oncoming vehicles.
- If the camera is not available due to long exposure to direct sunlight or high ambient temperatures.
- If the camera field of view is covered, dirty or damaged.
- If the camera is misaligned.

Delayed reaction

If the sensor system is exposed to environmental conditions that limit its function, the driver assistance systems may only be able to detect this with a delay. Therefore, the display that indicates that functions are impaired may be delayed when you first start driving or while driving.

Limits in certain driving situations

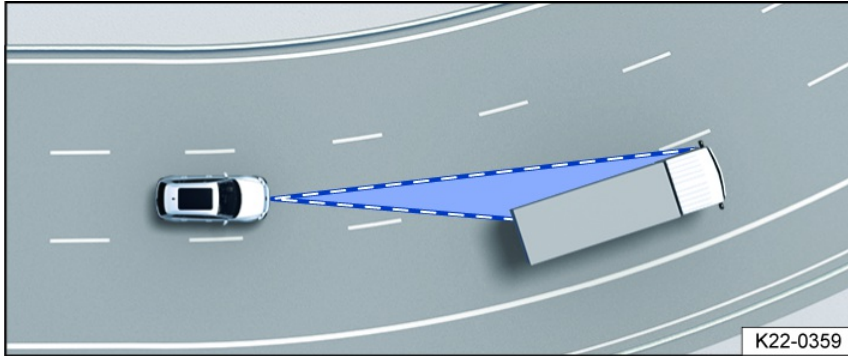

Fig. 86 Driving around curves.

The sensor system always measures straight ahead. Therefore, on tight curves, vehicles may be detected by mistake or vehicles driving ahead may not be detected.

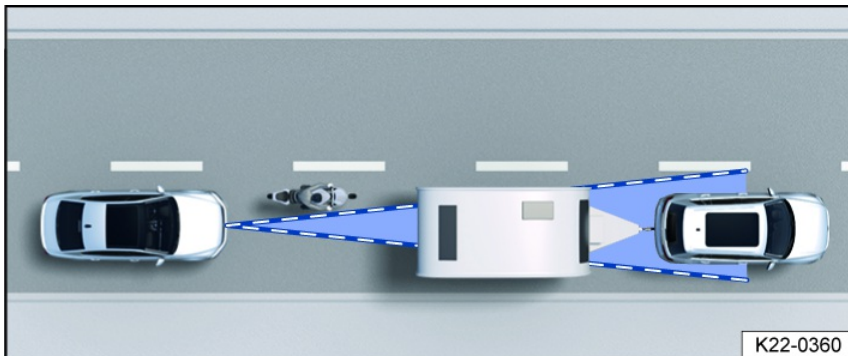

Fig. 87 Narrow vehicle.

Vehicles that are driving close to your vehicle but outside the sensor range, such as motorcycles, cannot be detected.

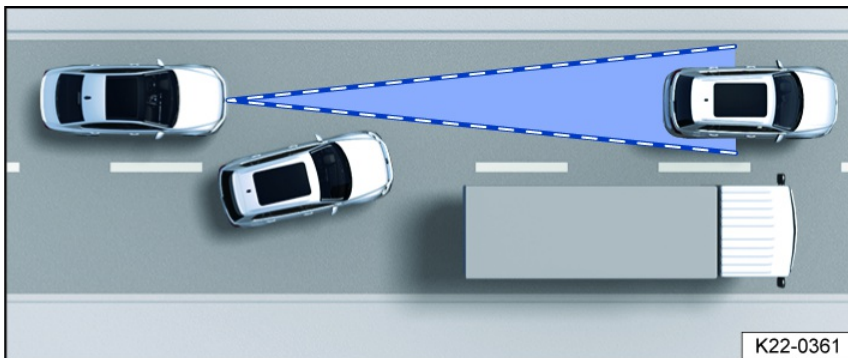

Fig. 88 Changing lanes.

Vehicles that change to your lane close in front of your vehicle cannot be detected. This also applies to vehicles with attachments exceeding the vehicle dimension:

Specific system limitations

In addition to the limits of the sensor system, every driver assistance system has additional system limitations linked to their function. Please also note these:

- Adaptive Cruise Control (ACC) ⇒ *System Limitations of ACC*.

- Autonomous Emergency Braking (Front Assist) ⇒ [System Limitations of Front Assist](#).
- Lane Assist ⇒ [Lane Assist system limitations](#).
- Comfort drive Travel Assist ⇒ [Introduction](#).
- Emergency Assist ⇒ [Introduction](#).
- Lane Change System (Side Assist) ⇒ [Side Assist system limitations](#).

Cruise control system

Introduction

The cruise control system helps to maintain a set speed.

Speed range

The cruise control system is available at speeds above approximately 20 km/h (approximately 15 mph) when driving forward.

Driving with the Cruise Control System

You can override the stored speed at any time, for example, to pass another vehicle. The regulation function is paused while the vehicle accelerates and then resumes the stored speed.

Displays

If the cruise control system is switched on, the instrument cluster display indicates the saved speed and the status of the cruise control system.

The following indicator lights may turn on depending on the driving situation and the instrument cluster version:

Cruise control system is switched on, speed regulation active.

If the cruise control system is not regulating the speed, the indicator lights are small or grey.

If no speed is stored, the instrument cluster display shows --- instead of the speed.

Driving downhill

The vehicle cannot maintain the saved speed in all driving situations. Always be ready to apply the brakes.

1. Use the electric drivetrain recuperation when traveling downhill for extended periods.

This relieves the strain on the brakes.

WARNING

If it is not possible to drive safely with enough distance and a constant speed, using the cruise control system may cause accidents and serious or fatal injuries.

- Always adapt your speed and distance to vehicles driving ahead based on the visual, weather, road, and traffic conditions. The driver is always responsible for the speed.
- Never use the cruise control system when visibility is poor, when there is not enough distance, or when roads are steep, winding, flooded, or slippery, for example from snow, ice, moisture, or gravel.
- Never use the cruise control system when driving off-road or on unpaved roads.

Operating the cruise control system

 Please read the introductory information and heed the Warnings and Notice ⇒  [Introduction](#).



Fig. 89 Left side of the multi-function steering wheel.

Switching on

1. Press the  button.

No speed is saved. At this stage, the limiter will not yet start regulating your speed.

Starting the regulation function

1. Press the  button while driving.

The cruise control system saves and controls the current speed.

Setting the speed

You can adjust the saved speed while the cruise control system is regulating the speed:

+ 1 km/h (1 mph): Press the  button gently.

- 1 km/h (1 mph): Press the  button gently.

+ 10 km/h (5 mph): Press the  button firmly or swipe it from the bottom to the top. Pressing for the first time changes to the next-largest tens digit (km/h) or fives digit (mph).

- 10 km/h (5 mph): Press the  button firmly or swipe it from the top to the bottom. Pressing for the first time changes to the next-smallest tens digit (km/h) or fives digit (mph).

To change the stored speed continuously, press and hold the respective button.

Your vehicle will adjust its current speed by accelerating or braking.

Canceling the regulation function

1. Press the  button briefly.

Or: Press the brake pedal.

The vehicle speed remains stored in the system.

Resuming the regulation function

1. Press the  button.

The cruise control system resumes and maintains the saved speed.

WARNING

There is the risk of an accident if you inadvertently resume at the saved speed or if the saved speed is too fast for the current road, traffic, or weather conditions. This may result in serious injury or even death.

- Check whether the saved speed is suitable for the current road, traffic, or weather conditions before you resume the cruise control system.
- Switch off the cruise control system if you do not require it.

Switching off

1. Press and hold the  button.

The cruise control system is switched off and the saved speed is deleted.

Switching to other driver assistance systems

Depending on the vehicle equipment, you can switch to the following driver assistance systems:

- Adaptive Cruise Control (ACC).

1. Press or swipe the **MODE** button.
2. Swipe to the left or right to select the system you want.
3. Press the **MODE** button.

Troubleshooting

 Please read the introductory information and heed the Warnings and Notice ⇒  **Introduction.**

Cruise control system malfunction

Malfunction. The yellow indicator light turns on.

- Switch off the cruise control system and seek assistance from an authorized Volkswagen dealer or authorized Volkswagen Service Facility. Volkswagen recommends contacting an authorized Volkswagen dealer or authorized Volkswagen Service Facility.

The regulation function is canceled automatically

- The vehicle has exceeded the stored speed for an extended period.
- No gear is engaged for driving forward.
- Braking assistance systems, for example ASR or ESC, are active.
- The vehicle has been braked by Autonomous Emergency Braking (Front Assist).
- If the problem persists, switch off the cruise control system and seek assistance from an authorized Volkswagen dealer or authorized Volkswagen Service Facility. Volkswagen recommends contacting an authorized Volkswagen dealer or authorized Volkswagen Service Facility.

Adaptive Cruise Control (ACC)

Introduction

Adaptive Cruise Control (ACC) maintains your selected speed. When the vehicle approaches a vehicle driving ahead, the ACC adjusts the speed automatically and maintains your set distance to the vehicle driving ahead.

Does this vehicle have ACC?

The vehicle has ACC if you can adjust ACC settings in the Assistance systems menu in the Infotainment system.

Speed range

You can set a speed between approx. 20 km/h (approx. 15 mph) and approx. 150 km/h (approx. 95 mph).

Driving with ACC

You can override the ACC system at any time. The regulation function is canceled when you apply the brakes. When you accelerate, the regulation function is paused while accelerating and then resumed with the speed set.

If a trailer is hitched, ACC is less dynamic.

Driver intervention request

 If automatic deceleration by the ACC is not sufficient or the system limits are reached, the ACC will prompt you – with a message in the instrument cluster – to also apply the brakes. The red warning light will also turn on and a warning tone will sound. Take over steering and be ready to brake.

⚠ WARNING

ACC is not a replacement for the driver's attention and works only within the system limitations. ACC cannot detect all driving situations and may not react, or may react with a delay, or may react in a way that is not desired. If you are careless, there is a risk of accidents, serious injuries and death.

- Always stay attentive and do not rely solely on the system. The driver is always responsible for control of the vehicle.
- Observe the system limitations ⇒ [System Limitations of ACC](#).
- Always adapt your speed and distance to vehicles driving ahead based on the visual, weather, road, and traffic conditions.
- Take over steering immediately if a driver intervention prompt appears in the instrument cluster display or the deceleration by ACC is not sufficient.
- Apply the brakes if the vehicle continues to roll unintentionally, e.g. after a driver intervention prompt.

Special driving situations

📖 Please read the introductory information and heed the Warnings and Notice ⇒ ⚠ [Introduction](#).

The functions described below depend on the vehicle equipment and are not available in all countries.

Stop-and-go traffic

ACC can brake the vehicle and bring it to a standstill. ACC remains active, and the instrument cluster display shows ACC is ready for a few seconds. In this time, the vehicle will automatically move again once the vehicle driving ahead starts.

Extend drive-readiness or reactivate:

1. Press the **RES** button.

Driving off when drive-readiness has ended and the vehicle driving ahead has already started moving:

1. Press the **RES** button.

Or: Briefly press the accelerator pedal.

The ACC does not stay active in the following scenarios:

- The stationary phase lasts several minutes.
- A vehicle door is opened.
- The vehicle's drive system is deactivated.

⚠ WARNING

If ACC is ready appears in the instrument cluster display and the vehicle driving ahead starts to move, your vehicle will start driving automatically. The vehicle may not be able to detect obstacles in the vehicle's path when this happens. This may cause accidents and serious injuries.

- Check the vehicle's path every time before you start driving and brake the vehicle if necessary.

System Limitations of ACC

📖 Please read the introductory information and heed the Warnings and Notice ⇒ ⚠ [Introduction](#).

Limits of the sensor system

ACC detects driving situations using the radar and ultrasonic sensors in the front of the vehicle and the camera behind the windshield. The radar sensor has a range of up to approx. 160 m (approx. 520 ft).

⚠ WARNING

If you use the ACC in situations outside system limitations, accidents and serious injuries may result and legal regulations may be violated.

- Be aware of the limitations of the sensor system ⇒ [Limits of the sensor system](#) and cancel the regulation in the situations described.

Unrecognizable objects

ACC only detects vehicles that are moving in the same direction or are stationary. The following will not be detected:

- Pedestrians
- Animals
- Vehicles crossing the street or oncoming vehicles
- Other stationary obstacles

Stationary vehicles

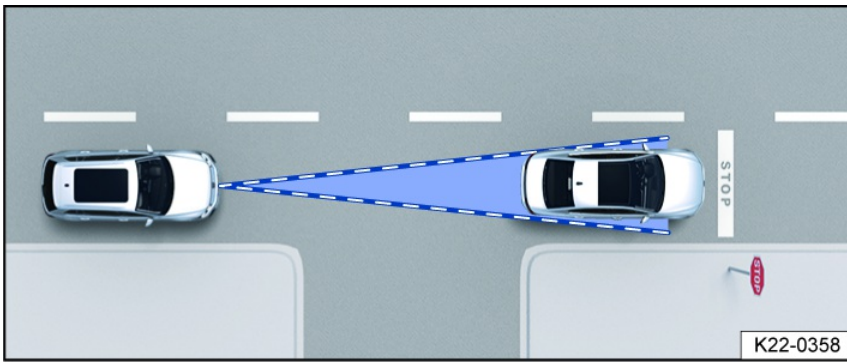

Fig. 90 Stationary vehicle.

ACC responds in a limited manner to stationary vehicles up to approx. 60 km/h (approx. 37 mph), provided that a stationary vehicle is detected as such and your own vehicle can be comfortably braked behind the stationary vehicle within the system limits of ACC. ACC does not perform emergency braking [fig. 90](#).

The reaction to stationary vehicles depends on the vehicle equipment and is not available in all countries.

Switching ACC on and off

Please read the introductory information and heed the Warnings and Notice → [Introduction](#).



Fig. 91 Left side of the multi-function steering wheel.

Switching on

1. Press the button.
ACC is not yet functioning.

Starting the regulation function

1. Press the **SET** button while driving forward.
ACC saves the current speed and maintains the set distance. If the current speed is outside the specified speed range, the ACC adjusts the minimum speed when driving too slowly or the maximum speed when driving too quickly.
ASR Sport and, depending on the vehicle equipment, ESC Sport are also deactivated.

The following indicator lights may turn on depending on the driving situation:

 ACC is regulating – no vehicle ahead detected.  ACC is regulating – vehicle ahead detected.

If the ACC is not functioning, the gray indicator lights come on.

Canceling the regulation function

1. Press the  button briefly.

Or: Press the brake pedal.

If the respective indicator light for the driving situation lights up gray, the speed and distance are saved.

If ASR Sport is activated, the regulation is automatically interrupted.

Resuming the regulation function

1. Press the  button.

ACC assumes the last set speed and the last set distance. The instrument cluster display shows the set speed, and indicator lights turn on corresponding to the driving situation.

Switching off

1. Press and hold the  button.

The set speed is deleted.

Switching to other driver assistance systems

Depending on the vehicle equipment, you can switch to the following driver assistance systems:

- Cruise Control System.

1. Press or swipe the  button.
2. Swipe to the left or right to select the system you want.
3. Press the  button.

Adjusting the ACC settings

 Please read the introductory information and heed the Warnings and Notice ⇒  *Introduction.*

Setting the distance

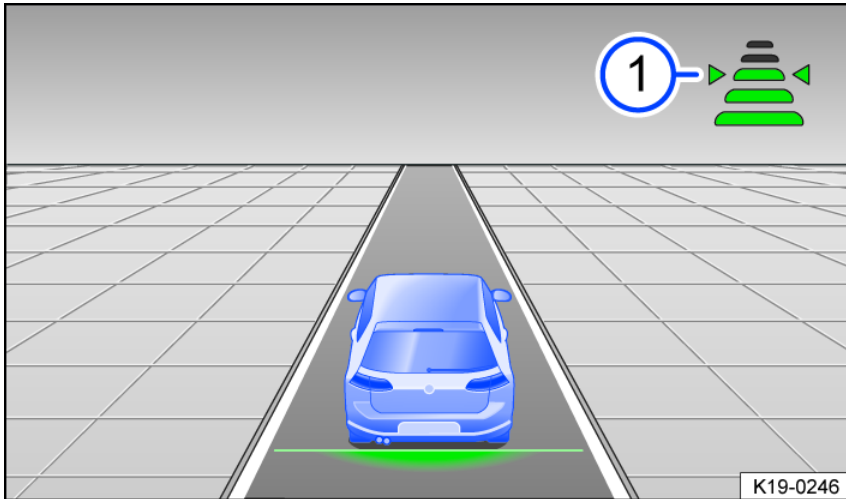







Fig. 92 In the instrument cluster display: set distance , ACC is regulating (general example).

You can set the distance at five levels from very short to very long:

1. Press the  button.
2. Press the  button or  button, or swipe vertically over the button area from  to  or .

Or: Press the  button repeatedly until the preferred distance is set.

The instrument cluster display shows the selected level *fig. 92* . Heed the country-specific regulations for minimum distance.

In the Assistance systems menu of the Infotainment system, you can choose whether you want the regulation to start at the distance that was set at the end of the journey or start at a preselected distance.

Setting the speed

You can adjust the stored speed within the specified speed range using the buttons on the multi-function steering wheel as follows:

+ 1 km/h (1 mph): Press the  button gently.

- 1 km/h (1 mph): Press the  button gently.

Press the  button firmly or swipe it from the bottom to the top. Pressing for the first time changes to the next-largest tens digit (km/h) or fives digit + 10 km/h (5 mph):
(mph).

- 10 km/h (5 mph): Press the  button firmly or swipe it from the top to the bottom. Pressing for the first time changes to the next-smallest tens digit (km/h) or fives digit (mph).

To change the stored speed continuously, press and hold the respective button.

WARNING

ACC cannot detect all driving situations correctly. If the vehicle is less than the minimum distance from the vehicle ahead and the difference in speed between the vehicle ahead and your own vehicle is so great that the speed deceleration from the ACC is not sufficient, there is a risk of a rear end collision. This may result in serious injury or even death.

- Always be ready to apply the brakes yourself.
- To override the speed and distance control, press the accelerator pedal. In this case, ACC will not brake automatically.
- Heed the country-specific regulations regarding minimum distance.
- Always set a longer distance when there is rain, snow, or poor visibility.

Adjusting the regulation function system settings

You can influence how the ACC reacts in a sporty driving style:

- Vehicles with Driving Mode Selection:
Select the desired driving mode.
- Vehicles without Driving Mode Selection:
Select the desired driving mode in the Assistance systems menu in the Infotainment system.

Troubleshooting

 Please read the introductory information and heed the Warnings and Notice ⇒  [Introduction](#).

ACC is not available

The yellow indicator light turns on.

- The radar sensor is dirty. Clean the radar sensor ⇒ [Vehicle care](#).
- The visibility of the radar sensor is limited due to weather conditions, such as snow, or from soap residue or coatings. Clean the radar sensor ⇒ [Vehicle care](#)
- Radar sensor visibility is limited by attachments, decorative frames on license plate holders, or stickers. Clear the area around the radar sensor ⇒ [Sensors and Cameras](#).
- The radar sensor is misaligned or damaged, for example as a result of damage to the front of the vehicle. Check if there is noticeable damage ⇒ [Sensors and Cameras](#).
- Malfunction or fault. Deactivate the vehicle's drive system and activate it again.
- Painting work was carried out on or structural modifications were made to the front of the vehicle ⇒ [Repairs and technical modifications](#).
- If the problem persists, contact an authorized Volkswagen dealer or authorized Volkswagen Service Facility. Volkswagen recommends contacting an authorized Volkswagen dealer or authorized Volkswagen Service Facility.

ACC is not functioning as expected

- The radar sensor is dirty. Clean the radar sensor ⇒ [Vehicle care](#).
- The ultrasonic sensors are soiled, obscured or damaged. Clean the ultrasonic sensors ⇒ [Vehicle care](#).
Clear the area around the ultrasonic sensors and check for damage ⇒ [Sensors and Cameras](#).
- The system limitations are not adhered to ⇒ [System Limitations of ACC](#).
- The brakes are overheating, and the regulation function has been automatically canceled. Let the brakes cool down and check the function again.
- If the problem persists, contact an authorized Volkswagen dealer or authorized Volkswagen Service Facility. Volkswagen recommends contacting an authorized Volkswagen dealer or authorized Volkswagen Service Facility.

 Additional information may be displayed in the vehicle status, depending on the malfunction ⇒ [Vehicle settings menu](#).

The Adaptive Cruise Control cannot start

Make sure the following requirements are met:

- The brake lights on the vehicle are functioning.
- The brake lights on the electronically connected trailer are functioning.

- ESC is not regulating.
- The brake pedal is not being pressed.

Unusual noises during automatic braking

This is normal and not a cause for concern.

Controls are responding differently than expected

Moisture, dirt and grease may limit the functioning of the controls.

1. Always keep the control panels clean and dry.

Front Assist

Introduction

Front Assist can recognize impending forward collisions and warn the driver. In addition, the system can provide support when braking and initiate an automatic braking maneuver.

The Front Assist system can help to avoid accidents but cannot replace the driver's attention.

Front Assist works solely within the system limitations. Warning times vary depending on the Traffic Situation and the driving behavior.

Range of functions

Front Assist includes the following additional functions, depending on the vehicle equipment and the country:

- Pedestrian Monitoring.
- Cyclist Monitoring.

The functions named are automatically active if Front Assist is switched on.

Recognizable objects

Autonomous Emergency Braking (Front Assist) can recognize the following objects, depending on the vehicle equipment and the country:

- Vehicles.
- Bikes.
- Pedestrians.

Driving with Front Assist

You can cancel automatic braking interventions by moving the steering wheel or pressing the accelerator pedal.

Automatic braking

Front Assist can brake the vehicle to a stop. The vehicle will not be held at a stop after that. Press the brake pedal.

The brake pedal feels more firm during an automatic braking maneuver.

WARNING

Front Assist is not a replacement for the driver's attention and works only within the system limitations. Front Assist cannot detect all driving situations and may not react, may react with a delay, or may react in a way that is not desired. If you are careless, there is a risk of accidents, serious injuries and death.

- Always stay attentive and do not rely solely on the system. The driver is always responsible for control of the vehicle.
- Observe the system limitations ⇒ *System Limitations of Front Assist*.
- Always adapt your speed and distance to vehicles driving ahead based on the visual, weather, road, and traffic conditions.
- Consider interrupting automatic Autonomous Emergency Braking (Front Assist) interventions if necessary.
- When Front Assist warns you, brake the vehicle immediately or maneuver around the obstacle, depending on the driving situation.
- If you are unsure which functions are included with your vehicle depending on the vehicle equipment and country, consult suitably qualified professionals before starting your journey. Volkswagen recommends contacting an authorized Volkswagen dealer or authorized Volkswagen Service Facility.

Warning levels and braking support

 Please read the introductory information and heed the Warnings and Notice ⇒  *Introduction*.

Speed ranges

Autonomous Emergency Braking (Front Assist) provides maximum support within these speed ranges:

- Response to vehicles: Approx. 5 km/h (approx. 3 mph) to approx. 250 km/h (approx. 155 mph).

- Response to bikes: Approx. 5 km/h (approx. 3 mph) to approx. 250 km/h (approx. 155 mph).
- Response to pedestrians: Approx. 5 km/h (approx. 3 mph) to approx. 85 km/h (approx. 53 mph).

The support system can involve an advance warning, an immediate warning, automatic braking or braking support. A distance warning may also be displayed.

Influencing factors

Whether and in which speed range Autonomous Emergency Braking (Front Assist) reacts to the named objects is dependent on the following factors:

- Type of object.
- Movement direction of the object.
- Speed of the object.
- Speed of the vehicle.

The work area can therefore be limited if the vehicle approaches an object very quickly and thus has little time to react.

Furthermore, not all warning levels are passed through in all situations. Depending on the speed, there may not be, for example, an advance warning or immediate warning, but rather an automatic braking maneuver that occurs straight away, so as to best protect the detected object.

Distance warning



Front Assist detects if there is a safety hazard from following the vehicle ahead too closely.

The indicator light turns on. Increase the distance.

Advance warning



Front Assist detects a possible collision and prepares the vehicle for possible emergency braking.

A warning tone sounds and the warning light turns on. Apply the brakes or maneuver to avoid the collision.

Immediate warning

If you do not respond to the advance warning, the brakes may be applied briefly to indicate the increasing risk of a collision. Apply the brakes or maneuver to avoid the collision.

Automatic braking

Autonomous Emergency Braking (Front Assist) can brake the vehicle automatically in several stages of increasing braking force. Reducing the vehicle speed may help to reduce the damage resulting from a collision.

Braking support

If the system detects that you are not braking enough before an impending collision, Front Assist can increase the braking force and thus help to reduce the risk of collision. The braking support is only active as long as you are firmly pressing the brake pedal.

System Limitations of Front Assist

 Please read the introductory information and heed the Warnings and Notice ⇒  **Introduction.**

Limits of the sensor system

Front Assist detects driving situations using a radar sensor in the front of the vehicle and the camera behind the windshield.

 **Note the limitations of the sensor system ⇒ *Limits of the sensor system*. Always remain attentive and intervene manually if necessary.**

After a vehicle start



Front Assist is not available or its availability is limited immediately after starting the vehicle. During this time, the white indicator light in the instrument cluster display comes on.

Unrecognizable objects

Autonomous Emergency Braking (Front Assist) may not react or may react with a delay to the following objects:

- If there are oncoming vehicles or vehicles crossing the street
- Oncoming pedestrians; generally no reaction to people without Pedestrian Monitoring.
- Stationary or oncoming cyclists; also no reaction to cyclists crossing the road without Cyclist Monitoring.
- Pedestrians and cyclists who are not detected as such, for example because they are fully or partially hidden.

Functional limitations

In addition to the situations described under the sensor system limitations, Front Assist may not react, may react with a delay, or may react in a way that is not desired in the following example situations:

- When driving in reverse
- If ESC is regulating or is malfunctioning.
- If multiple brake lights on the vehicle are malfunctioning.

- If multiple brake lights are malfunctioning on a trailer or bicycle rack that is connected to the vehicle electrical system.
- If the vehicle is accelerating very quickly or the accelerator pedal is pressed all the way down
- In unclear traffic situations, for example if vehicles driving ahead are braking quickly or are turning
- When entering or exiting a tunnel.
- If Front Assist is malfunctioning

Switching off Front Assist

Depending on the system, Front Assist may not be suitable in the following situations and must be switched off if they occur ⇒ :

- If the vehicle is not being driven on public roads, for example during off-road driving or on a racetrack.
- If the vehicle is being towed or transported
- If add-ons cover the radar sensor or camera.
- If the camera or radar sensor is malfunctioning.
- Following a violent impact affecting components within the range of the radar sensor, e.g. following a rear-end collision.
- If the windshield is damaged in the camera field of view.
- If there are multiple unwanted activations

WARNING

If you use Front Assist in these situations, accidents and serious injuries or even death could occur.

- Switch off Front Assist in the situations described.

Using Front Assist

 Please read the introductory information and heed the Warnings and Notice ⇒  [Introduction](#).

When you switch on the ignition, Front Assist with all of its equipment- and country-dependent functions is automatically switched on.

 However, Front Assist is not available or its availability is restricted while the white indicator light is turned on.

Volkswagen recommends always leaving Front Assist and all of its equipment- and country-dependent functions switched on. Exceptions ⇒ [System Limitations of Front Assist](#).

Switching on and off

You can switch Autonomous Emergency Braking on and off manually and view the switched on condition.

In the Infotainment system:

1. Open the Assistance systems menu.
2. Switch Autonomous Emergency Braking on or off in the corresponding submenu.

 If you switch off Front Assist, all of its equipment- and country-dependent functions are also switched off. The yellow indicator light turns on in the instrument cluster display.

If Front Assist was automatically deactivated, e.g. if towing is detected, the yellow indicator light also comes on.

Setting Up Equipment- and Country-dependent Functions

If Front Assist is switched on, you can set the following settings in the assistance systems menu of the Infotainment system depending on the equipment and country:

- Switch on and off distance warning.
- Switch on and off advance warning.
- Set the warning period for the advance warning.

Troubleshooting

 Please read the introductory information and heed the Warnings and Notice ⇒  [Introduction](#).

Front Assist starts

The white indicator light comes on.

- Autonomous Emergency Braking (Front Assist) is temporarily not available or has limited availability. After driving straight for a short distance, Autonomous Emergency Braking is available again and the indicator light goes out. If the vehicle does not drive, the indicator light stays on.

Front Assist has limited availability or is not available

The yellow indicator light turns on. In addition, a message is shown in the instrument cluster display.

- The radar sensor or camera field of view is dirty. Clean the radar sensor and windshield ⇒ [Vehicle care](#).
- The visibility of the radar sensor or camera is limited due to weather conditions, such as snow, or from soap residue or coatings. Clean the radar sensor and

windshield ⇒ [Vehicle care](#).

- Radar sensor visibility is limited by attachments, decorative frames on license plate holders, or stickers. Clear the area around the radar sensor ⇒ [Sensors and Cameras](#).
- The camera's view is limited by attachments or stickers. Keep the area around the camera field of view clear ⇒ [Sensors and Cameras](#).
- The radar sensor or the camera is misaligned or damaged, for example as a result of damage to the front of the vehicle or the windshield. Check if there is noticeable damage ⇒ [Sensors and Cameras](#).
- The camera was automatically deactivated due to a high ambient temperature or long exposure to direct sunlight. Front Assist will be available once the camera is available again.
- Painting work was carried out on or structural modifications were made to the front of the vehicle ⇒ [Repairs and technical modifications](#).
- If the problem persists, turn off Autonomous Emergency Braking and contact suitably qualified professionals. Volkswagen recommends contacting an authorized Volkswagen dealer or authorized Volkswagen Service Facility.

Front Assist is not functioning as expected or has been triggered multiple times unnecessarily

- The radar sensor or camera field of view is dirty. Clean the radar sensor and windshield ⇒ [Vehicle care](#).
- The system limitations are not adhered to ⇒ [System Limitations of Front Assist](#).
- Low-lying sun or darkness.
- If the problem persists, turn off Autonomous Emergency Braking and contact suitably qualified professionals. Volkswagen recommends contacting an authorized Volkswagen dealer or authorized Volkswagen Service Facility.

Controls are responding differently than expected

Moisture, dirt and grease may limit the functioning of the controls.

1. Always keep the control panels clean and dry.

Lane Keeping System (Lane Assist)

Introduction

Lane Assist helps the driver to stay in a lane, within the system limitations. This function is not suitable for, and not designed for, autonomously keeping your vehicle in a lane.

If the system detects that the vehicle is coming too close to a lane marker, Lane Assist warns the driver with corrective steering. The driver can override the corrective steering at any time.

Speed range

Lane Assist is ready to take control (active system status) when a lane marking is detected within the system limits above approximately 60 km/h (approximately 35 mph).

WARNING

Lane Assist is not a replacement for the driver's attention and works only within the system limitations. Lane Assist cannot detect all driving situations and may not react, may react with a delay, or may react in a way that is not desired. If you are careless, there is a risk of accidents, serious injuries and death.

- Always stay attentive and do not rely solely on the system. The driver is always responsible for keeping the vehicle within the lane.
- Observe the system limitations ⇒ [Lane Assist system limitations](#).
- Always adapt your speed and distance to vehicles driving ahead based on the visual, weather, road, and traffic conditions.
- Always keep your hands on the steering wheel so that you are prepared to steer at any time.
- Override immediately by steering if the system intervenes when it should not.
- Pay attention to indicators in the instrument cluster display and respond to the prompts accordingly when the traffic situation allows.

Lane Assist system limitations

 Please read the introductory information and heed the Warnings and Notice ⇒  [Introduction](#).

Limits of the sensor system

Lane Assist detects lane markings with the camera behind the windshield.

 Observe the limits of the camera ⇒ [Limits of the sensor system](#). Always be attentive and intervene yourself if necessary!

Lane markings not detected or not correctly recognized

Lane Assist does not correctly detect all lane markings. If lane markings are not detected or if markings are incorrectly detected as lane markings, Lane Assist may

fail to intervene when it should or may intervene when not desired. In addition to the situations specified in the camera limitations, this may also occur in the following situations, among others:

- If lane markings are not present.
- When the driving style is very dynamic.
- When not on highways or well-developed roads.
- On poor road surfaces, road structures or objects.
- In the event of reflections or dazzling effects.

Always be attentive and intervene yourself if necessary by overriding unwanted interventions by the system immediately. Temporarily switch off Lane Assist if required.

Lane Assist not available

Lane Assist is not available under the following conditions (inactive system status):

- The vehicle speed is less than around 55 km/h (around 30 mph).
- Lane Assist has not detected a lane marking.
- If lanes and curves are too narrow.
- Temporarily, when the driving style is very dynamic.
- When the turn signals are switched on before a manual lane change.
- When the driver oversteers during a system intervention.
- When there is no reaction from the driver to a driver intervention prompt.

Driving with Lane Assist

 Please read the introductory information and heed the Warnings and Notice ⇒  Introduction.

Switching on and off

You can view the switched on condition of Lane Assist in the Infotainment system. You can also switch Lane Assist on and off there.

1. Open the Assistance systems menu.
2. Switch Lane Assist on or off in the corresponding submenu.

 If there is a system malfunction, Lane Assist may switch off automatically.

Displays

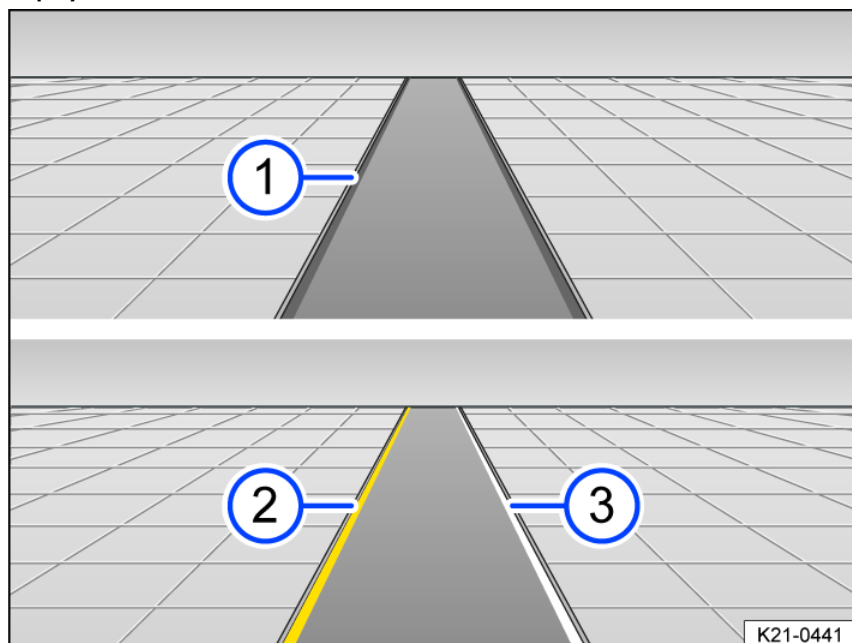

Fig. 93 In the instrument cluster display: displays of Lane Assist

- ① Grey line: lane marking detected. The system is not ready to monitor on the indicated side.
- ② Yellow line: Lane marking detected. The system is monitoring on the indicated side.
- ③ White line: Lane marking detected. The system is ready to monitor on the indicated side.

Depending on the vehicle equipment, further details about lane marking, such as broken road markings, may also be shown on the instrument cluster display.

One of the following indicator lights will light up, depending on the driving situation:

 **System active and ready to control.**  **System in operation (corrective steering intervention).**

If the indicator light does not light up, Lane Assist is not ready for operation on both sides (inactive system status) or is switched off.

 **If Travel Assist is actively controlling, there will not be any steering intervention and no Lane Assist display.**

Driver intervention request

If there is no steering activity, Lane Assist prompts you to drive in the center of your lane with an indicator in the instrument cluster display and warning chimes.

If you do not respond accordingly, Lane Assist becomes inactive.

Depending on the vehicle equipment, semi-automatic vehicle control in a medical emergency (Emergency Assist) is activated when Emergency Assist is switched on in the Infotainment system.

Independently of steering activity, you are also prompted by an indicator on the instrument cluster display and by a warning chime to drive in the middle of the lane the corrective steering intervention takes a long time.

Steering wheel vibration

The following situation may cause the steering wheel to vibrate:

- A lane is no longer detected during a sharp corrective steering intervention by the system.

In addition, you can select the Vibration or Steering wheel vibration option in the Assistance systems menu in the Infotainment system. If you select this option, the steering wheel will vibrate if Lane Assist is active and you drift onto a road lane marking that the system has detected.

Troubleshooting

 **Please read the introductory information and heed the Warnings and Notice** ⇒  **Introduction.**

Lane Assist not available

The yellow indicator light turns on. In addition, a message is shown in the instrument cluster display.

- The camera field of view is dirty. Clean the windshield ⇒ [Vehicle care](#).
- The camera's view is limited due to weather conditions, such as snow, or from soap residue or coatings. Clean the windshield ⇒ [Vehicle care](#).
- The camera's view is limited by attachments or stickers. Keep the area around the camera field of view clear ⇒ [Sensors and Cameras](#).
- The camera is misaligned or damaged, for example as a result of damage to the windshield. Check if there is noticeable damage ⇒ [Sensors and Cameras](#).
- The camera was automatically deactivated due to a high ambient temperature or long exposure to direct sunlight. Lane Assist will be available once the camera is available again. Deactivate the vehicle's drive system and activate it again.
- Malfunction or fault. Deactivate the vehicle's drive system and activate it again.
- If the problem persists, contact an authorized Volkswagen dealer or authorized Volkswagen Service Facility. Volkswagen recommends contacting an authorized Volkswagen dealer or authorized Volkswagen Service Facility.

 **It can take a few seconds once the ignition has been switched on for a system fault to be recognized.**

 **If Lane Assist is not available, Emergency Assist is not available either.**

 **If Lane Assist is not available, Travel Assist is not available either.**

The system is functioning differently than expected

1. Do not mount any objects on the steering wheel.

Controls are responding differently than expected

Moisture, dirt and grease may limit the functioning of the controls.

1. Always keep the control panels clean and dry.

Comfort drive Travel Assist

Introduction

Thanks to the comfort drive Travel Assist, within the system limitations, the vehicle can maintain a distance, which has been preselected by the driver, to the vehicle in front and hold the preferred position within the lane (adaptive lane guidance).

Does this vehicle have Travel Assist?

The vehicle has Travel Assist, if the  button on the multi-function steering wheel is available.

Speed range

Travel Assist regulates from approximately 20 km/h (approximately 15 mph), or from approximately 0 km/h (0 mph) for extended adaptive lane guidance. This speed range may vary depending on the country.

System Limitations of Travel Assist

Travel Assist detects driving situations using the same sensor technology as the Adaptive Cruise Control (ACC) and Lane Keeping System (Lane Assist).

 Also observe the system limitations of and information on ACC and Lane Assist. Always remain attentive and intervene manually if necessary.

Driving with Travel Assist

Travel Assist automatically regulates the speed and steers the vehicle. Within the system limitations, Travel Assist can also bring the vehicle to a halt behind a stopping vehicle and drive on again.

You can override the Travel Assist regulation function at any time.

Displays

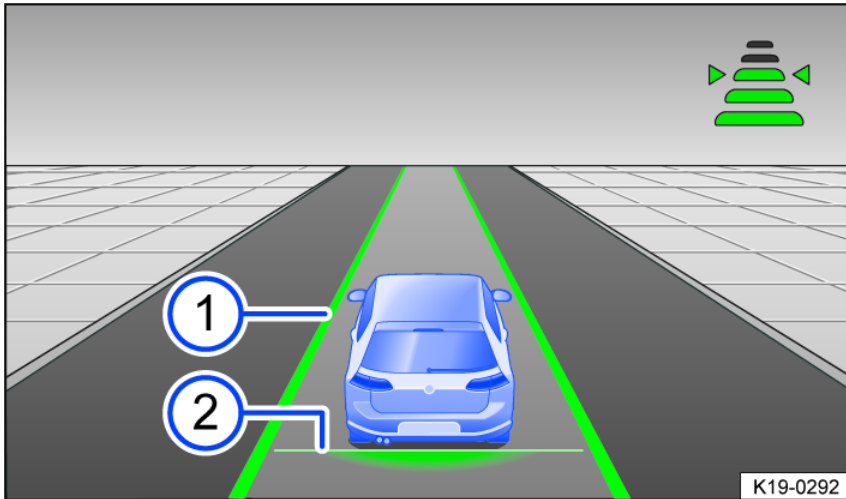

Fig. 94 In the instrument cluster display: Display during active control (general example).



① The color of the lane marking shows the status of adaptive lane guidance.

- Green: adaptive lane guidance is active.
- Grey: adaptive lane guidance is inactive.

② Set distance.

Depending on the vehicle equipment, further details may also be shown on the instrument cluster display, such as broken road markings and road users driving in front.

Indicator lights on the instrument cluster display show the Travel Assist status:

 Travel Assist active, Adaptive Cruise Control and adaptive lane guidance active.  Travel Assist inactive, Adaptive Cruise Control (ACC) active and adaptive lane guidance inactive.  Travel Assist deactivated, no regulation.

Driver intervention request

If you remove your hands from the steering wheel, the system will ask you to take over the steering wheel after a few seconds with a message in the instrument cluster display and with audible warnings.

If you do not respond to this, Travel Assist is deactivated.

Alternatively, depending on the vehicle equipment, semi-automatic vehicle control in a medical emergency (Emergency Assist) is activated when Emergency Assist is switched on in the Infotainment system.

WARNING

Travel Assist is not a replacement for the driver's attention and works only within the system limitations. Travel Assist cannot detect all driving situations and may not react, or may react with a delay, or may react in a way that is not desired. If you are careless, there is a risk of accidents, serious injuries and death.

- Always stay attentive and do not rely solely on the system. The driver is always responsible for control of the vehicle.
- Observe the system limitations of ACC ⇒ [System Limitations of ACC](#) and Lane Assist ⇒ [Lane Assist system limitations](#).
- Always adapt your speed and distance to vehicles driving ahead based on the visual, weather, road, and traffic conditions.
- Always keep your hands on the steering wheel so that you are prepared to steer at any time.
- Take over steering immediately if a driver intervention prompt appears in the instrument cluster display or the deceleration by Travel Assist is not sufficient.

- Apply the brakes if the vehicle continues to roll unintentionally, e.g. after a driver intervention prompt.

Operating Travel Assist

 Please read the introductory information and heed the Warnings and Notice   **Introduction.**



Fig. 95 Left side of the multi-function steering wheel.

Switching on and starting the regulation function

1. During forward travel with ACC switched on, press the  button on the multi-function steering wheel.

The vehicle switches from ACC to Travel Assist.

Depending on the driving situation, the vehicle switches to the following system status in Travel Assist:

- If ACC is regulating, Travel Assist maintains the current speed and the preset distance from the vehicle driving ahead (system status inactive).
At the same time, the vehicle is kept in its lane by steering movements when road markings are detected (system status active).
- If ACC is not regulating, Travel Assist is switched on, but stays deactivated.

1. Press the **SET** button.

Travel Assist switches the driving situation accordingly to an active or inactive system status.

The indicator/warning light corresponding to the driving situation comes on in the instrument cluster display. A notification is also displayed.

Canceling the regulation function

1. Press the  button briefly.

Or: Press the brake pedal.

The set distance remains saved.

Changing to ACC

1. Press the  button on the multi-function steering wheel.

The vehicle switches from Travel Assist to the system status of ACC corresponding to the driving situation.

Adjusting further settings

The further operation of Travel Assist corresponds to the operation of the ACC ⇒ [Adjusting the ACC settings](#).

Using assisted lane changing

📖 Please read the introductory information and heed the Warnings and Notice ⇒ [Introduction](#).

When you activate the 3-blink turn signal, the vehicle can assist with lane changing on multi-lane highways within the system limitations, as long as sufficient space is detected around the vehicle.

Assisted lane changing uses the same sensor technology as the Lane Change System (Side Assist) and the parking systems. Therefore carefully read all information on Side Assist and the notes on the parking systems. Also observe the system limitations and information there.

Requirements

Assisted lane changing is only available during a forwards journey on multi-lane highways which are included in the navigation data of the Infotainment system, and only at speeds above approximately 72 km/h (approx. 45 mph).

In addition, Travel Assist must be switched on and the 3-blink turn signal must have been activated in the vehicle settings ⇒ [Vehicle settings menu](#).

Displays

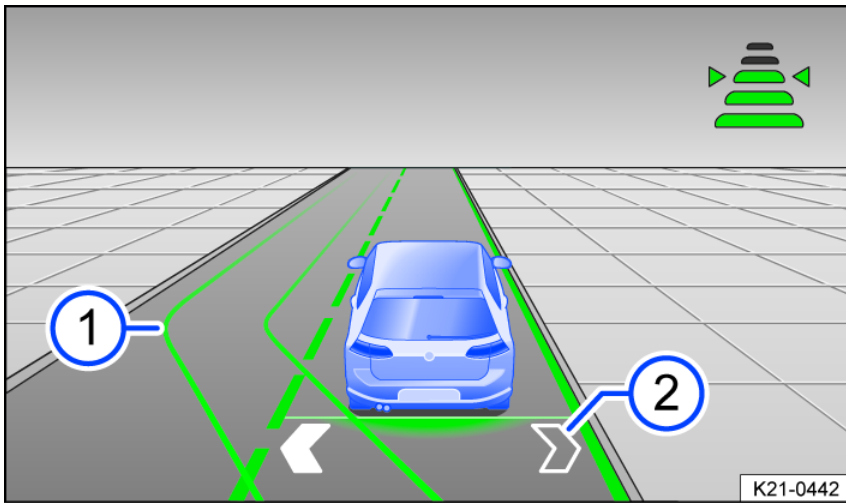

Fig. 96 In the instrument cluster display: displays for assisted lane changing (general example).

- ① Indicated lane changing (green), assisted lane changing is carried out. The respective neighboring lane is additionally highlighted.
- ② Arrows on your own lane show the status of assisted lane changing.
 - Grey: assisted lane changing on the respective lane side not possible.
 - White: assisted lane changing on the respective lane side possible. The respective neighboring lane is additionally highlighted.

Switching assisted lane changing on and off

You can switch assisted lane changing on and off in the Infotainment system.

1. Open the Assistance systems menu.
2. Select Travel Assist.
3. Switch assisted lane changing on or off as a sub-function of Travel Assist.

🔧 If there is a system malfunction, assisted lane changing can be switched off automatically or be interrupted during lane changing.

🔧 If Side Assist is not available, assisted lane changing is not available either.

Activating assisted lane changing

1. Press the **SET** button while driving.

Assisted lane changing is activated. The arrows on your own lane on the instrument cluster display are shown in grey [fig. 96](#).

Changing lanes

If the system has not detected any objects in the detection zone of the sensors and assisted lane changing to a neighboring lane is possible, the respective lane is depicted on the instrument cluster display next to your own lane. In addition, the arrow on the corresponding lane side is shown in white [fig. 96](#).

1. Activate the 3-blink turn signal on the respective side.

The vehicle changes lane. A message is also displayed in the instrument cluster display and the lane change indicated [fig. 96](#).

During lane changing, the vehicle activates the turn signal automatically on the relevant vehicle side. When lane changing has been completed, the turn signal is

automatically switched off.

WARNING

Assisted lane changing is not a replacement for the driver's attention and works only within the system limitations. Assisted lane changing cannot detect all driving situations or all objects in the surrounding area and may not react, or may react with a delay, or may react in a way that is not desired. If you are careless, there is a risk of accidents, serious injuries and death.

- Before changing lanes, always make sure that it is safe to do so. In particular, objects approaching quickly may not be detected in good time.
- Always keep your hands on the steering wheel and be ready to change the speed and/or direction of travel yourself.

Deactivating assisted lane changing

1. Press the  button briefly.

Or: Press the brake pedal.

Assisted lane changing and Travel Assist are deactivated.

Troubleshooting

 Please read the introductory information and heed the Warnings and Notice ⇒  **Introduction.**

Comfort drive Travel Assist is not available or is not working as expected

The yellow indicator light turns on. In addition, a message is shown in the instrument cluster display.

- There is a malfunction in the sensor system. Check the causes and troubleshooting measures described in the information on ACC and Lane Assist.
- Malfunction or fault. Deactivate the vehicle's drive system and activate it again.
- The system limitations are not adhered to.
- If the problem persists, contact an authorized Volkswagen dealer or authorized Volkswagen Service Facility. Volkswagen recommends contacting an authorized Volkswagen dealer or authorized Volkswagen Service Facility.

Take over the steering

The white warning light will come on and a message will be shown in the instrument cluster display.

You have let go of the steering wheel for a few seconds.

1. Take hold of the steering wheel and take over steering the vehicle.

Take over the steering immediately

The red warning light will come on and a message will be shown in the instrument cluster display. An audible warning will sound or the steering wheel will vibrate, depending on the driving situation.

You have let go of the steering wheel for a long period of time or the system limits have been reached.

1. Immediately take hold of the steering wheel and take over steering the vehicle.

Comfort drive Travel Assist switches off automatically

- Vehicles without Emergency Assist:
You have let go of the steering wheel for a long period of time.
- Malfunction or fault. Deactivate the vehicle's drive system and activate it again.
- If the problem persists, contact an authorized Volkswagen dealer or authorized Volkswagen Service Facility. Volkswagen recommends contacting an authorized Volkswagen dealer or authorized Volkswagen Service Facility.

The regulation function is canceled unexpectedly

Vehicle without assisted lane changing:

- You have operated the turn signal.

Assisted lane changing is not available

The yellow indicator light turns on. In addition, a message is shown in the instrument cluster display.

- There is a malfunction in the sensor system. Check the causes and corrective measures described in the information on the Lane Change System (Side Assist) and in the notes on the parking systems.
- If the problem persists, contact an authorized Volkswagen dealer or authorized Volkswagen Service Facility. Volkswagen recommends contacting an authorized Volkswagen dealer or authorized Volkswagen Service Facility.

Assisted lane changing is interrupted or is not available

A message is shown in the instrument cluster display.

- The vehicle can no longer detect any lane markings.
- You have let go of the steering wheel.
- You were steering too strongly with or against the movement.
- You activated the turn signal multiple times or the turn signal and high beam lever is locked in place.
- The vehicle speed is less than around 64 km/h (around 40 mph).
- The vehicle detected objects in the area which prevent assisted lane changing.
- You are not on a multi-lane highway.

Semi-automatic vehicle control in a medical emergency (Emergency Assist)

Introduction

Emergency Assist can recognize driver inactivity and can automatically keep the vehicle in its lane and, if necessary, slow it down to a stop. The system can hereby actively help to avoid an accident or reduce the consequences of an accident.

Emergency Assist system limitations

Emergency Assist detects driving situations using the same sensor technology as the Adaptive Cruise Control (ACC) and Lane Keeping System (Lane Assist).

WARNING

Emergency Assist is not a replacement for the driver's attention and works only within the system limitations. Emergency Assist cannot detect all driving situations and may not react, may react with a delay, or may react in a way that is not desired. Emergency Assist also cannot always avoid accidents and serious injury by itself. If you are careless, there is a risk of accidents, serious injuries and death.

- Always stay attentive and do not rely solely on the system. The driver is always responsible for control of the vehicle.
- Observe the system limitations of ACC ⇒ [System Limitations of ACC](#) and Lane Assist ⇒ [Lane Assist system limitations](#).
- Always adapt your speed and distance to vehicles driving ahead based on the visual, weather, road, and traffic conditions.

Driving with Emergency Assist

 Please read the introductory information and heed the Warnings and Notice ⇒  [Introduction](#).

Switching on and off

You can switch Emergency Assist on and off in the Assistance systems menu in the Infotainment system.

When it is switched on, Emergency Assist is only active under the following conditions:

- Travel Assist or Lane Assist is switched on.
- The system must detect lane markers on the left and right side of the vehicle.

 If there is a system malfunction, Emergency Assist may switch off automatically.

 If Lane Assist is not available, Emergency Assist is not available either.

Driver intervention request

Using warning chimes and brief braking maneuver, Emergency Assist prompts an inactive driver to take over control of driving. In addition, a message is shown in the instrument cluster display and the volume of the Infotainment system is decreased.

System intervention

If you do not respond, the system can brake the vehicle and keep it in its lane. The following indicator light will come on in the instrument cluster display:

 System is regulating.

You can cancel the regulation at any time by accelerating rapidly, braking or steering as the traffic situation allows.

If Emergency Assist is active, other road users will be warned as follows:

- The emergency flashers are switched on after a short delay.
- The vehicle's horn sounds, depending on the speed.

If the remaining stopping distance is sufficient, the vehicle slows down, if necessary, to a stop.

As soon as the vehicle comes to a standstill, the following happens:

- The electronic parking brake is switched on.

- The doors are unlocked.
- The interior lighting is switched on.

⚠ WARNING

Emergency Assist cannot detect all driving situations and may react in a way that is not desired. Accidents and serious injuries or even death could result.

- If the vehicle behaves unexpectedly, you can stop intervention of Emergency Assist.
- Switch off the Lane Keeping System (Lane Assist).
- Do not use the comfort drive Travel Assist.
- Seek assistance from suitably qualified professionals and have the system checked. Volkswagen recommends contacting an authorized Volkswagen dealer or authorized Volkswagen Service Facility.

Troubleshooting

📖 Please read the introductory information and heed the Warnings and Notice ⇒ ⚠ Introduction.

🚗 SOS Semi-automatic vehicle control in a medical emergency (Emergency Assist) not available

Malfunction or fault. The yellow indicator light turns on. In addition, a message is shown in the instrument cluster display.

1. Deactivate the vehicle's drive system and activate it again.
2. If the problem persists, turn off Emergency Assist and contact suitably qualified professionals. Volkswagen recommends contacting an authorized Volkswagen dealer or authorized Volkswagen Service Facility.

Controls are responding differently than expected

Moisture, dirt and grease may limit the functioning of the controls.

1. Always keep the control panels clean and dry.

Lane Change System (Side Assist)

📖 Introduction

The Lane Change System (Side Assist) helps the driver to discern the traffic situation behind the vehicle.

Radar sensors behind the rear bumper cover monitor the area behind the vehicle. The system measures the distance and difference in speed to other vehicles and informs the driver through visual signals in the housing of the outside mirrors.

Only use Side Assist on secure roads.

Speed range

If Side Assist is switched on, it is active at speeds of approx. 15 km/h (approx. 9 mph) and above. Side Assist is deactivated at speeds below approx. 10 km/h (approx. 6 mph).

⚠ WARNING

Side Assist is not a replacement for the driver's attention and works only within the system limitations. Side Assist cannot detect all driving situations and all objects in the surrounding environment, and may not provide warnings, may provide warnings with a delay, or may provide warnings in a way that is not desired. If you are careless, there is a risk of accidents, serious injuries and death.

- Always stay attentive and do not rely solely on the system. The driver is always responsible for control of the vehicle and changing lanes.
- Observe the system limitations ⇒ *Side Assist system limitations*.
- Always adapt your speed and distance to vehicles driving ahead based on the visual, weather, road, and traffic conditions.
- Always keep your hands on the steering wheel so that you are prepared to steer at any time.
- Pay attention to the displays in the outside mirror housings and in the instrument cluster display, and act accordingly.

Side Assist system limitations

📖 Please read the introductory information and heed the Warnings and Notice ⇒ ⚠ Introduction.

Limits of the sensor system

Side Assist detects driving situations via the radar sensors in the rear area.

👤 Note the limits of the radar sensors ⇒ *Limits of the sensor system* and always pay attention!

Functional limitations

In addition to the situations specified in the sensor system limitations, Side Assist may not correctly interpret the traffic situation in the following situations, among others:

- When driving in the center of two lanes.
- When lanes have different widths.
- When certain types of equipment are on the side of the road, such as high or offset guard rails.

Restricted visibility

Sunlight may reduce the visibility of the visual display in the outside mirror.

Calibration

The radar sensors calibrate once, on the first kilometer of a journey after the vehicle is delivered, and then again if the sensor technology has been repaired. The range of the sensors may be limited during the calibration phase.

Driving with Side Assist

 Please read the introductory information and heed the Warnings and Notice   [Introduction](#).

Switching on and off

You can view the switched on condition of Side Assist in the Infotainment system. You can also switch Side Assist on and off there.

1. Open the Assistance systems menu.
2. Switch Side Assist on or off in the corresponding submenu.

When it is switched on, the yellow indicator light  in the housing of the outside mirror comes on once briefly.

 If there is a system malfunction, Side Assist may switch off automatically.

Deactivation in Trailer Mode



If you use the trailer hitch installed at the factory and have made the required electrical connection, Side Assist will switch off automatically. Once a trailer is connected to the vehicle electrical system and the driver starts to drive, a message will appear in the instrument cluster display stating that Side Assist is deactivated. Once you have disconnected the electrical connection, Side Assist will be automatically switched on again.

For trailer hitches that were not installed at the factory, you must switch Side Assist off and on again manually.

Displays in the Outside Mirror



Fig. 97 In the outside mirror housing: displays of Side Assist.

 **flashing:** a vehicle has been detected in the blind spot and the turn signal on the side where the vehicle was detected is activated.  **lit:** your own vehicle is being overtaken or you are overtaking another vehicle with a speed difference of up to approx. 15 km/h (approx. 9 mph). There is no indicator if the passing speed is clearly faster.

The faster another vehicle approaches, the sooner the display in the outside mirror housing will turn on.

Lane change system “Side Assist Plus”

In vehicles with a Lane Keeping System (Lane Assist), a corrective steering intervention warns you when a possibly critical situation is detected when changing lanes (information level, warning level), if Lane Assist is switched on. The steering intervention also occurs if you activate the turn signal for the respective side. If you oversteer the steering intervention, an additional warning is provided by a steering wheel vibration. Steering wheel vibration must also be activated in the Assistance systems menu in the Infotainment system.

Brightness

The brightness of the visual display adapts it self automatically to the ambient brightness.

You can set the default brightness of the display in the Assistance systems menu in the Infotainment system. Side Assist is not active while making the settings.

Troubleshooting

 Please read the introductory information and heed the Warnings and Notice ⇒  [Introduction](#).

Side Assist malfunction

Malfunction or fault. The yellow indicator light in the instrument cluster display comes on. In addition, the yellow central warning light  comes on.

1. Deactivate the vehicle's drive system and activate it again.
2. If the problem persists, contact an authorized Volkswagen dealer or authorized Volkswagen Service Facility. Volkswagen recommends contacting an authorized Volkswagen dealer or authorized Volkswagen Service Facility.

Malfunctioning sensor view, malfunction message, system switches off automatically

- Clean the radar sensors and remove the stickers or attachments from the radar sensors or the bumper ⇒ [Exterior care and cleaning](#), ⇒ [Sensors and Cameras](#)
- Check if there is any noticeable damage ⇒ [Sensors and Cameras](#).
- If the problem persists, contact an authorized Volkswagen dealer or authorized Volkswagen Service Facility. Volkswagen recommends contacting an authorized Volkswagen dealer or authorized Volkswagen Service Facility.

The system is functioning differently than expected

- The radar sensors could be dirty. Clean the radar sensors ⇒ [Exterior care and cleaning](#).
- The radar sensors could be covered by water.
- The field of view of the radar sensors is limited by weather conditions, such as snow, or by dirt, soap residue or coatings. Clean the radar sensors ⇒ [Exterior care and cleaning](#).
- The system limitations are not adhered to ⇒ [Side Assist system limitations](#).
- The vehicle could be damaged in the radar sensor area, for example from parking barriers. Check if there is any noticeable damage ⇒ [Sensors and Camera](#).
- The field of view of the radar sensors is limited by attachments, bicycle racks or stickers. Keep the area around the radar sensors clear ⇒ [Sensors and Cameras](#).
- Painting work or structural modifications were carried out in the area of the radar sensors, on the vehicle rear or on the suspension ⇒ [Repairs and technical modifications](#).
- The side windows have been covered with after-market tinting films ⇒ [Repairs and technical modifications](#).
- If the problem persists, contact an authorized Volkswagen dealer or authorized Volkswagen Service Facility. Volkswagen recommends contacting an authorized Volkswagen dealer or authorized Volkswagen Service Facility.

Controls are responding differently than expected

Moisture, dirt and grease may limit the functioning of the controls.

1. Always keep the control panels clean and dry.

Parking and maneuvering

Parking the vehicle

Parking

WARNING

Parking the vehicle incorrectly can result in the vehicle rolling, even on slight downhill slopes. Accidents and serious or fatal injuries could result.

- When parking the vehicle, always follow the steps in the specified order.
- Before exiting the vehicle, make sure the electronic parking brake is activated and the red  warning light next to the gear indicator comes on. The red indicator light in the instrument cluster display **PARK** will come on.

1. Press and hold the brake pedal.
2. Set the electronic parking brake.

The vehicle's drive system is deactivated. The red warning light  next to the gear indicator and the red indicator **PARK** in the instrument cluster display come on.

3. On uphill and downhill slopes, turn the steering wheel so that the vehicle will roll into a curb if it begins moving.
4. Release the brake.
5. Exit the vehicle ⇒ . Pay attention to other road users.
6. Take all vehicle keys with you and lock the vehicle.

WARNING

If you leave children, people requiring assistance or animals unattended in the vehicle, they may accidentally set the vehicle in motion or be subjected to very high or low temperatures. There is a risk of accidents and serious or fatal injuries.

- Never leave children, people requiring assistance or animals unattended in the vehicle.

To avoid damage and dangerous situations, always park the vehicle in a suitable parking area ⇒ .

NOTICE

Any unevenness in the ground, as well as sand or mud, may prevent the vehicle from being parked safely. This can result in damage to the vehicle.

- Always park the vehicle on solid and level ground.

NOTICE

Vehicle components that are low to the ground such as the bumpers, spoilers, and parts of the suspension may collide with objects protruding up from the ground when they are driven over. The vehicle can be damaged.

- Drive carefully over driveways, ramps, curbs and fixed barriers, as well as when driving through dips.

Electronic parking brake



Fig. 98 On the driving mode selector: Button (P) for the electronic parking brake (general example).

Switching on

1. When the vehicle is stationary, press the button for the electronic parking brake *fig. 98* (P).

Or: Switch off the ignition.

(P) If the electronic parking brake is switched on, the red warning light will come on next to the gear indicator.

The red **PARK** indicator in the instrument cluster display will also come on.

Switching off

1. Press the brake pedal and engage selector lever position **D**, **B**, **R** or neutral **N**.

The red warning light (P) as well as the indicator **PARK** will turn off.

Switching On If You Leave the Vehicle Incorrectly

If you leave the vehicle with the ignition switched on, a gear engaged or neutral position **N** selected and the red (P) indicator light comes on, the electronic parking brake has been switched on ⇒ ⚠.

⚠ WARNING

Parking the vehicle incorrectly can result in the vehicle rolling, even on slight downhill slopes. Accidents and serious or fatal injuries could result.

- When parking the vehicle, always follow the steps of the parking procedure in the specified order.
- Before exiting the vehicle, make sure the electronic parking brake is activated and the red (P) warning light next to the gear indicator comes on.

Anti-roll function

The vehicle's anti-roll function can be temporarily deactivated in the Infotainment system. The electronic parking brake is switched off and the vehicle is in roll mode e.g. in a car wash or for towing ⇒ !.

Requirements

- ✓ Vehicle is stationary.
- ✓ The ignition is switched on.

Deactivate the anti-roll function:

1. Press the brake pedal.
2. Put the vehicle in neutral **N**.
3. Confirm the Deactivating the anti-roll function. message in the Infotainment system.

Or: Open the vehicle settings in the Infotainment system ⇒ *Vehicle settings menu*.

Open the Brakes submenu.

Switch on the function.

A message will appear permanently in the instrument cluster display. A warning chime will sound if necessary.

Activate the anti-roll function:

1. Apply the brakes and select a gear.

The anti-roll function is activated and the vehicle is ready to drive.

Or: Switch off the ignition.

The anti-roll function is activated. The electronic parking brake is switched on.

NOTICE

If the electronic parking brake switches on automatically in a car wash or during towing, this could cause damage to the vehicle.

- Always deactivate the anti-roll function in the Infotainment system.
- Leave the remote control vehicle key in the vehicle. Otherwise, the ignition will switch off automatically and the anti-roll function will be activated again.

Emergency braking function

Only use the emergency braking function in an emergency, if the vehicle cannot be stopped using the brake pedal ⇒ .

1. Press and hold the  button.

The vehicle will brake abruptly. A warning chime will also sound at the same time.

WARNING

The electronic parking brake is not designed for braking the vehicle. The braking distance will be significantly longer because only the rear wheels will be braked under certain circumstances. This could result in accidents and serious or fatal injuries.

- Always use the brake pedal to brake the vehicle and never the electronic parking brake unless it is an emergency.

 **Noises can be heard when you switch the electronic parking brake on or off. This may also occur during an automatic check.**

Troubleshooting

Electronic parking brake holding force is too low

The red  indicator light next to the gear indicator blinks. The vehicle is stationary. A message will also appear in the instrument cluster display.

Electronic parking brake not fully closed.

1. Park the vehicle in another location or on a flat surface and secure it against rolling away.

and **BRAKE** / **electronic parking brake malfunction**

The red  indicator light next to the gear indicator in the instrument cluster blinks. The red **BRAKE** brake warning light or the yellow  central warning light is also shown in the instrument cluster display.

There is a system malfunction.

1. Select a gear.
2. Press the electronic parking brake button  again.

If the red indicator light  comes on and the display **PARK** appears without a further warning light in the instrument cluster, the vehicle is parked safely.

Version 1: **is still on**

1. If the yellow  central warning light is still displayed, get professional assistance immediately. Volkswagen recommends contacting an authorized Volkswagen dealer or authorized Volkswagen Service Facility.

Version 2: **BRAKE** is still on

 **Do not continue driving!**

1. If the red brake warning light **BRAKE** is still illuminated, do not drive any further.
2. Contact an authorized Volkswagen dealer or authorized Volkswagen Service Facility for assistance.

button for the electronic parking brake faulty

If the electronic parking brake button is pressed, the red indicator light  next to the selector lever will blink.

Button for the electronic parking brake faulty.

1. Switch off the ignition to automatically switch on the electronic parking brake.
2. Contact an authorized Volkswagen dealer or authorized Volkswagen Service Facility. Volkswagen recommends contacting an authorized Volkswagen dealer or authorized Volkswagen Service Facility.

/ **Electronic parking brake malfunction**

The yellow central warning light comes on. The  symbol with a message is additionally shown in the instrument cluster display.

1. Contact an authorized Volkswagen dealer or authorized Volkswagen Service Facility. Volkswagen recommends contacting an authorized Volkswagen dealer or authorized Volkswagen Service Facility.

The electronic parking brake is working, but does not switch off

- Charging connector is inserted.
- The 12 V vehicle battery is drained ⇒ [Preparing and Performing a Jump-start](#).

Auto Hold

Auto Hold secures the vehicle from rolling away when it is stationary, without having to hold the vehicle with the brake pedal.

Depending on the vehicle equipment, your vehicle may feature the Auto Hold function.

Requirements

- ✓ The driver door must be closed.
- ✓ The vehicle is drive-ready.

With the transmission in neutral position, Auto Hold does not switch on or off. As a result, the vehicle will not be secured from rolling away ⇒ .

Switching on

1. Open the vehicle settings in the Infotainment system ⇒ [Vehicle settings menu](#).
2. Open the Vehicle menu.
3. Open the Exterior menu.
4. Open the Brakes menu.
5. Switch on Auto Hold.

Auto Hold is ready to use, but the vehicle may not be kept stationary ⇒ .

AUTO HOLD The grey indicator light comes on in the instrument cluster when Auto Hold is active.

Auto Hold remains switched on after the vehicle's drive system has been reactivated.

Keeping the vehicle stationary using Auto Hold

1. When Auto Hold is switched on, bring the vehicle to a stop using the brakes.
2. Release the brake ⇒ .

The vehicle is kept stationary.

AUTO HOLD The green indicator light comes on in the instrument cluster when Auto Hold is active.

The hold on the vehicle will end when the vehicle starts to drive or the requirements for Auto Hold are not met.

Switching off

Auto Hold can only be switched off when the brake pedal is pressed ⇒ .

1. Switch off Auto Hold in the vehicle settings in the Infotainment system ⇒ [Vehicle settings menu](#).

WARNING

Auto Hold is not a replacement for the driver's attention and works only within the system limitations. The vehicle cannot be secured in every single situation, for example on inclines or slippery ground. If you do not take care, there is a risk of accidents and serious injuries.

- Always stay attentive and do not rely solely on the system. The driver is always responsible for control of the vehicle.

- Make sure the indicator light for Auto Hold in the instrument cluster display lights up if the vehicle is to be kept stationary.
- Never exit the vehicle when the engine is running, even if Auto Hold is switched on.

! NOTICE

In car washes where the vehicle is pulled, the wheels may lock if Auto Hold is switched on. This can lead to vehicle damage.

- Switch off Auto Hold before going through a car wash.

Information about the parking systems

Safety instructions

! WARNING

Parking systems are not a replacement for the driver's attention and can only operate within the limitations of the system. The parking systems cannot detect all driving situations and may not react, or may react with a delay, or may react in a way that is not desired. If you are careless, there is a risk of accidents, serious injuries and death.

- Always stay attentive and do not rely solely on the system. The driver is always responsible for control of the vehicle.
- Always keep an eye on the direction of travel and the vehicle surroundings when parking.
- Pay particular attention to small children, animals and objects when parking.
- Do not allow the parking system's display to distract you from the traffic around you.
- Bear in mind that the parking system may not react if the vehicle approaches too quickly and will not issue a warning.
- Always adapt your speed and driving style to the visibility, weather, road and traffic conditions.

! NOTICE

When you maneuver in a parking space without a curb, the vehicle may be damaged by obstacles.

- Keep a safe distance of approx. 50 cm (around 20 in) from walls and buildings.

Sensor and camera boundaries

Various sensors and cameras that detect the vehicle surroundings ultrasonically, by radar waves, and visually are located on and in the vehicle. The various parking systems use different combinations of sensors. All sensors have technical and physical limits ⇒ :

- In some situations, some objects may not be detected, e.g. trailer draw bars, narrow poles, fences, posts, and trees, extremely low or high obstacles, or trunk lids that are opening or already open ⇒ .
- The parking system coverage areas have "blind" spots in their range where they cannot detect people and objects.
- Dirt, ice, or water on the sensors and cameras may be detected as obstacles or prevent the detection of objects in some cases. In addition to dirt and snow, soap residue or other coatings can also impair the sensor range → page , *Exterior care and cleaning*.
- External noises and certain surfaces on objects and clothing can affect the sensor signals. In some situations, people and objects may not be detected or may be detected incorrectly.
- Certain objects, such as small posts or grating, cannot be shown or cannot be adequately shown due to the resolution of the screen and if there is insufficient lighting.
- The cameras only show two-dimensional images on the screen. Due to the lack of depth of field, it may be difficult or impossible to identify protruding objects or recesses in the road.

 Volkswagen recommends practicing with the parking systems in a location or parking space with no traffic in order to become acquainted with the functions.

Requirements

 The use of parking systems, e.g. with camera assistance, may not be allowed in some countries and regions according to legal provisions.

General information

So that the sensors and cameras can detect the area surrounding the vehicle as well as possible and display this image on the Infotainment system screen, the following requirements must be met.

- ✓ The doors and trunk lid are closed.
- ✓ The outside mirrors must not be folded in.

- ✓ The sensors or cameras are not covered by attachments or decorative license plate holder frames. The decorative license plate holder must not protrude at the sides or bottom.
- ✓ The vehicle must be on level ground.
- ✓ The vehicle must not be loaded primarily in the rear or on one side.
- ✓ Drive-ready mode must be established.
- ✓ Braking assistance systems such as ESC or ASR are switched on.

 If you use any other functions in the Infotainment system while you are parking, the parking function and its warning chimes will be deactivated.

Finding a suitable parking space

- ✓ The length and width of the parking space must be larger than the vehicle measurements and provide enough space to maneuver.
- ✓ The distance when driving past the parking space is approx. 1 m (approx. 3 feet).
- ✓ **Vehicles with Park Assist Plus:** The speed when passing the parking space is, for parking spaces parallel to the road, maximum approx. 40 km/h (approx. 25 mph), and for parking spaces across the road maximum approx. 20 km/h (approx. 12 mph).
- ✓ **Vehicles with Park Assist (Park Assist Plus) with memory function:** the speed for calibrating the parking process must be a maximum of approx. 40 km (approx. 25 mph).

Automatic braking intervention

A parking system's automatic braking support helps to avoid collisions, if an obstacle is detected.

Parking systems with braking support

Depending on the vehicle equipment, the vehicle has parking systems with a maneuvering and/or emergency braking function ⇒ .

The automatic braking support of Park Distance Control is only possible in the rear area.

WARNING

The automatic braking support is not a replacement for the driver's attention and works only within the system limitations. In some driving situations, the automatic braking support may be limited or may intervene in a way that is not desired or may not engage at all. If you are careless, there is a risk of accidents, serious injuries and death.

- Always stay attentive and do not rely solely on the system. The driver is always responsible for control of the vehicle.
- In a hazardous situation, apply the brakes using the brake pedal to avoid collision with an obstacle.
- React quickly to parking system warnings, e.g. Park Distance Control.

Requirements

- ✓ When maneuvering, the vehicle is not driving faster than approx. 10 km/h (approx. 6 mph).
- ✓ A parking system has been switched on.

What happens during an automatic braking intervention?

If there is an obstacle, the vehicle brakes to a stop and is kept stationary for around two seconds.

1. After braking, press the brake pedal to keep the vehicle stationary.
2. Check your surroundings.

Park Assist Plus: If the speed is too high, the vehicle will brake to a stop. The parking process can then be resumed.

Depending on the vehicle equipment, there may be a message on the instrument cluster display.

Switching on and off

Automatic braking is activated or deactivated when a parking system is switched on or off by the driver.

Maneuver braking for Park Distance Control

The maneuver braking is automatically switched on each time the ignition is switched on.

- To avoid a collision with an obstacle in front of the vehicle, apply the brakes using the brake pedal because no automatic braking support will take place.
- To cancel the automatic braking support at the rear, briefly press the accelerator pedal ⇒ .

Deactivate function:

1. Tap the  function key in the screen of the Park Distance Control.
2. Apply the setting.

General information

 Switch the parking system off temporarily if automatic braking support happens too frequently or when undesired and maneuver the vehicle carefully, for example when driving off-road or parking in your garage.

 If the maneuver braking function for Park Distance Control intervenes to stop the vehicle, the function will be inactive for a distance of approx. 5 m (approx. 16 ft) when driving in the same direction. It will become active again if the gear or selector lever position changes.

 The parking process is canceled following Park Assist Plus emergency braking, e.g. if an obstacle has been detected.

 Following a Rear Traffic Alert emergency braking intervention, it will take approx. 10 seconds before automatic braking support can occur again.

Troubleshooting

The parking system is functioning differently than expected

- The conditions of the parking system are not met → page , *Requirements*.
- The sensors are dirty or covered in ice or the camera lens is dirty and the camera image is not clear → page , *Exterior care and cleaning*.
- Sources of noise, such as a jackhammer or driving over cobblestones, can interfere with the ultrasonic signal.
- The vehicle is damaged in the area of the sensors or camera, for example from parking barriers, or the paint may have been changed or other structural modifications may have been made near the sensors or camera, for example to the vehicle front end or to the suspension.
- The areas detected by the sensors or camera may be blocked by accessories such as bicycle racks.

Fault displays

1. Note any messages on the instrument cluster display and in the Infotainment system.

NOTICE

If you use the parking system despite a malfunction, the vehicle may be damaged.

- Contact an authorized Volkswagen dealer or authorized Volkswagen Service Facility in the event of a parking system malfunction. Volkswagen recommends contacting an authorized Volkswagen dealer or authorized Volkswagen Service Facility.

No sensor range or the parking system has been switched off

If a sensor malfunctions, the sensor area is deactivated.

If a sensor malfunctions, the sensor area is deactivated. The sensor area affected can be displayed in the Infotainment system by the  symbol. The parking system may be completely switched off.

If Park Distance Control is malfunctioning, a continuous tone will sound for several seconds when you switch it on. Where applicable, a message will appear in the instrument cluster display.

1. Check if one of the causes listed is responsible.
2. Once the source of the issue has been resolved, switch the system on again.
3. If the problem persists, contact an authorized Volkswagen dealer or authorized Volkswagen Service Facility. Volkswagen recommends contacting an authorized Volkswagen dealer or authorized Volkswagen Service Facility.

After a wheel change, Park Assist (Park Assist Plus) parks inaccurately

If, after a wheel change, Park Assist Plus parks inaccurately, e.g. with an increased or reduced distance from the curb, the system may have to acquire the wheel sizes again.

1. Drive the vehicle over a longer distance, including around bends.
Park Assist Plus automatically learns the new wheel sizes after an ignition cycle.

Park Assist (Park Assist Plus) with memory function does not detect the saved parking space

The vehicle may not be able to recognize the area surrounding the saved parking space.

1. Stop the vehicle in the immediate vicinity of the saved vehicle path.
 - Or:** do not use the parking system in very poor weather and lighting conditions.
 - Or:** clean the front camera, if necessary.
 - Or:** check whether an Internet connection is available. The parking system always uses geocoordinates to determine the vehicle position.

Camera for Park Assist (Park Assist Plus) with Memory Function Deactivated

The assist systems camera was automatically deactivated due to a high ambient temperature or long exposure to direct sunlight. Park Assist Plus with memory function will be available once the camera is available again.

1. If necessary, deactivate the vehicle's drive system and activate it again.

Park Distance Control (PDC)

Introduction

Park Distance Control assists the driver when parking and warns if there are obstacles.

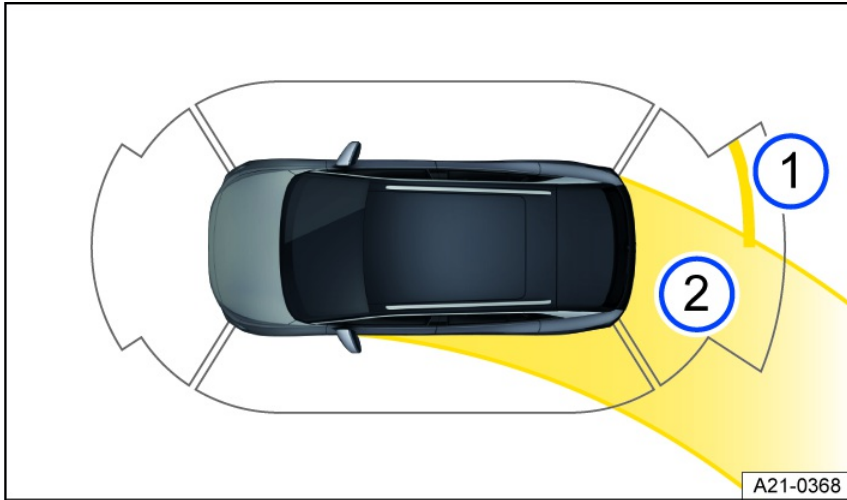

Fig. 99 Infotainment system: Display of Park Distance Control (general example).

- ① Obstacle detection.
- ② Steering lock.

System function

Using ultrasound sensors, the Park Distance Control detects the distance of the vehicle from an obstacle.

The Park Distance Control warns you of a collision via colored segments on the screen of the Infotainment system and via warning chimes *fig. 99*, ⇒ ⓘ.

If the driver does not respond to an approaching obstacle, automatic braking support may kick in ⇒ ⚠.

⚠ WARNING

Park Distance Control is not a replacement for the driver's attention and works only within the system limitations. Park Distance Control might not be able to detect some obstacles and may not react, may react late, or may react in a way that is undesired. If you do not take care, there is a risk of accidents and serious injuries.

- Always stay attentive and do not rely solely on the system. The driver is always responsible for control of the vehicle.
- React quickly to the Park Distance Control visual warnings and chimes.
- Brake the vehicle using the brake pedal before reaching an obstacle.

ⓘ NOTICE

The system will only provide visual and audible warnings for obstacles within the vehicle's path. The collision area has been reached, at the latest, when the penultimate segment on the Park Distance Control screen is displayed or a continuous warning tone sounds. There is a risk of vehicle damage.

- Always brake the vehicle in good time before reaching an obstacle.

ⓘ NOTICE



Depending on the vehicle equipment, distances to obstacles in the side areas are also displayed. Any obstacles that enter these areas from the outside are not displayed. The vehicle may be damaged in this instance.

- In order to fully scan and display the side areas, move the vehicle a few yards forward or back.

Screen display

Red section of the image: Nearby obstacle. The vehicle is at risk. Apply the brakes. **Yellow section of the image:** Obstacle in the path of the vehicle. The vehicle is at risk. Steer around the obstacle. **Grey section of the image:** Obstacle outside of the vehicle's path or a malfunction in the sensor area. ⓘ⚠ Maneuver braking deactivated or malfunctioning. ⚠ Mute the warning chimes. ⓘ There is a system malfunction in the area that is detected (depending on vehicle equipment). The colors may vary.

Park Distance Control settings

1. Tap the  control for parking functions in the upper section of the center console.
2. Tap the  function key.
3. Select a setting, e.g. automatic activation when driving forward or maneuver braking.

Driving with a trailer

If a trailer electrical system is connected, the rear and side sensors of the Park Distance Control are not switched on:

- You are not warned about obstacles.
- The maneuver braking is also deactivated automatically.

Switching Park Distance Control (PDC) on and off

 Please read the introductory information and heed the Warnings and Notice ⇒  and  Safety instructions.

Switching on

1. Select the reverse gear.

Or: tap the  control in the upper section of the center console. Then tap the  function key in the Infotainment system, if necessary.

Or: The vehicle will roll backward.

Switching off

1. Tap the  function key.

Or: the vehicle is driving forward at more than approx. 10 km/h (approx. 6 mph) up to approx. 15 km/h (approx. 9 mph).

Or: tap the  control in the upper section of the center console.

Or: the electronic parking brake is switched on.

Automatic activation when driving forward

If the vehicle slowly approaches an obstacle, Park Distance Control is automatically activated.

1. Tap the  control in the upper section of the center console.
2. Switch the function on or off.

If the driver switches off Park Distance Control, no further automatic activation occurs.

Automatic activation is available again under following conditions:

- The vehicle has been accelerated to more than approx. 15 km/h (approx. 9 mph) and then the speed has fallen below this again.
- Or:** the ignition has been switched off and on again.

 If an obstacle is detected in front of the vehicle, the display in the Infotainment system is activated. If the vehicle approaches further, warning chimes also sound.

Rear View Camera (Rear View)

Introduction

The Rear View Camera system in the rear of the vehicle makes it easier for the driver to see behind the vehicle and assists when parking.

System function

The Rear View Camera system shows the area behind the vehicle on the Infotainment system screen. Depending on the mode and vehicle equipment, orientation lines may assist in the view toward the rear ⇒ .

WARNING

The Rear View Camera system is not a replacement for the driver's attention and works only within the system limitations. Using the camera image to estimate the distance to people or obstacles may not be precise. If you do not take care, there is a risk of accidents and serious injuries.

- Always stay attentive and do not rely solely on the system. The driver is always responsible for control of the vehicle.
- Bear in mind that camera lenses can enlarge and distort the field of vision.

 The orientation lines superimposed on the camera image are shown by the system regardless of the vehicle's surroundings. There is no automatic obstacle detection by the camera while it is active. The driver must evaluate whether the vehicle will fit in the parking space.

 If a trailer is connected to the factory-installed trailer hitch, all orientation lines for the rear area are hidden in the camera image.



 If a camera is installed in the trunk lid, the orientation lines are also hidden if the trunk lid is open.

Switching the Rear View Camera system on and off

📖 Please read the introductory information and heed the Warnings and Notice ⇒ ⚠️ and ⚠️ Safety instructions.



Switching on

1. Select the reverse gear.

Or: tap the  control in the upper section of the center console. If available, then tap the  function key in the Infotainment system.

Switching off







1. The vehicle drives at more than approx. 15 km/h (approx. 9 mph).

Or: Tap the  or  function key on the screen of the Infotainment system.

Parking (Rear View Camera system with parking mode selection)

📖 Please read the introductory information and heed the Warnings and Notice ⇒ ⚠️ and ⚠️ Safety instructions.

Screen display

 **Perpendicular parking:** Guide lines help when parking in reverse perpendicular to the road.  **Cross traffic:** Depiction of the area behind the vehicle and the areas to the side of the vehicle at a wide angle.  **Red line:** Boundary or safety distance from the vehicle.  **Yellow lines:** the vehicle's path based on the steering angle.  **Green horizontal lines:** Boundaries.  Adjust the brightness, contrast, and color.

USA and Canada: If the camera image on a parking system has been switched on by engaging the reverse gear, no function keys are displayed for safety reasons. These function keys can be displayed again by tapping the function key .

Parking mode: Parking perpendicular to the road

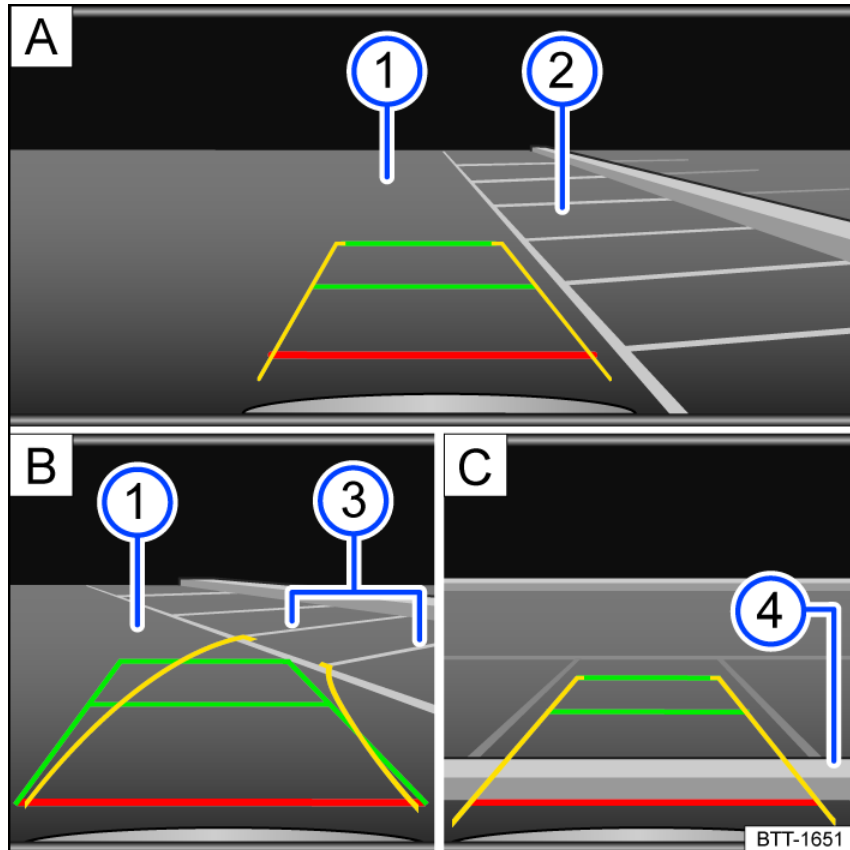















Fig. 100 Infotainment system: Parking perpendicular to the road.

-  Searching for a parking space.
-  Steering toward the selected parking space.
-  Aligning the vehicle within the parking space.

-  Road surface.
-  Parking space.
-  Side boundary of the parking space.
-  Rear boundary of the parking space.

1. Press the  control panel for parking functions before driving past the selected parking space. Then tap the  function key in the Infotainment system, if necessary.

- To select the parking mode, tap the  function key in the Infotainment system.
- Position your vehicle in front of the parking space *fig. 100*  2.
- Steer so that the yellow lines lead into the parking space. The green and yellow lines must align with the side boundary lines *fig. 100*  3.
- Stop when the red line reaches the rear boundary *fig. 100*  4.

Area View

Introduction

Area View provides an overview of the entire vehicle environment in real time. This function helps you recognize obstacles in good time in situations where there might be blind spots.

System function

Area View has several cameras, e.g. Rear View Camera system, front camera, and cameras in the outside mirrors, to show the vehicle environment on the Infotainment system screen ⇒ .

The functions and displays of Area View may vary depending on the vehicle equipment, e.g. if Park Distance Control is available and is also displayed.

WARNING

Area View is not a replacement for the driver's attention and works only within the system limitations. Using the camera image to estimate the distance to people or obstacles may not be precise. If you do not take care, there is a risk of accidents and serious injuries.



- Always stay attentive and do not rely solely on the system. The driver is always responsible for control of the vehicle.
- Bear in mind that camera lenses can enlarge and distort the field of vision.

Switching on and off

 Please read the introductory information and heed the Warnings and Notice ⇒  and  Safety instructions.



Switching on

- Select the reverse gear.

Or: tap the  control in the upper section of the center console. Then tap the  function key on the Infotainment system screen.

Switching off

- Drive faster than approx. 15 km/h (approx. 9 mph).

Or: Tap the  or  function key on the screen of the Infotainment system.

Or: tap the  control for parking functions.

Changing the camera perspective

 Please read the introductory information and heed the Warnings and Notice ⇒  and  Safety instructions.

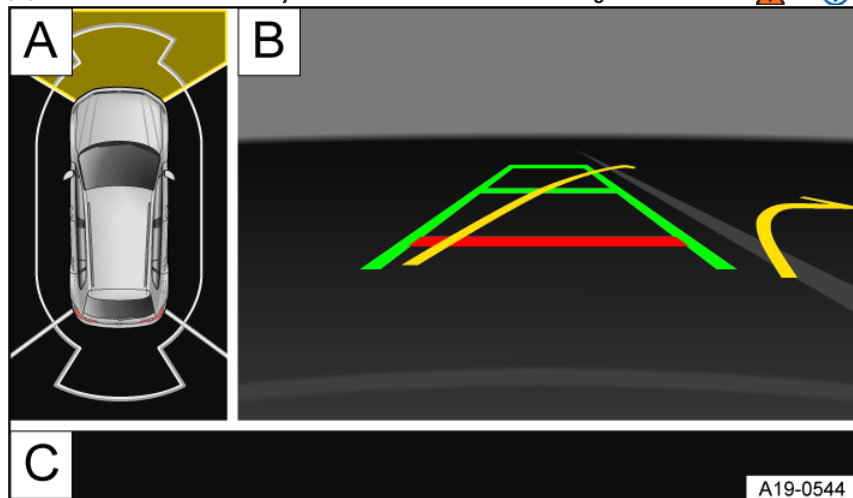





Fig. 101 Infotainment system: Area View in the "Front angled parking" mode (general example).

-  Bird's eye view with selectable sections of the screen.
-  Camera image.
-  Area for the function keys of Area View.

Switching between camera images

1. Tap the function keys on the image border to select a display *fig. 101* .

Sections of the screen

Two sections of the screen will be shown in the Infotainment system *fig. 101*:

Left screen  The vehicle is displayed from a bird's-eye view. By tapping on one section, the display changes to the right section of the screen.

Right screen  Depending on the section selected on the left screen, separate camera images will be displayed.

Screen display

 Front perpendicular parking.  Rear perpendicular parking.  Front cross traffic.  Rear cross traffic.



Park Assist Plus

Introduction

Park Assist (Park Assist Plus) detects a suitable parking space and automatically maneuvers the vehicle during the parking process.

The availability of Park Assist Plus depends on the vehicle equipment.

System function

Park Assist Plus steers, controls the gears and accelerates and brakes the vehicle ⇒ , ⇒ .

Available functions

- Display suitable parking spaces.
- Select or change the parking scenario.
- Driving into a suitable parallel parking space or parking bay.
- Parking maneuver to exit a suitable parallel parking space. Perpendicular parking spaces are not supported.

The driver should continuously monitor the area surrounding the vehicle ⇒ .

Automatic braking support may intervene if there are obstacles in the vehicle's path or in dangerous situations.

 Automatic, hands-free parking with Park Assist Plus may be prohibited or limited in some regions. Use Park Assist Plus only where permitted by legal provisions.

Driving with a trailer

Park Assist Plus cannot be activated if a trailer is connected to the electrical system.

If the trailer hitch was not installed at the factory, Park Assist Plus must be manually deactivated when towing a trailer.

WARNING

Park Assist Plus is not a replacement for the driver's attention and works only within the system limitations. Park Assist Plus cannot detect all driving situations and may not react, or may react with a delay, or may react in a way that is not desired. If you are careless, there is a risk of accidents, serious injuries and death.

- Always stay attentive and do not rely solely on the system. The driver is always responsible for control of the vehicle.
- Only drive the vehicle into the parking space if you possess a valid driving license.
- Abide by the traffic regulations in the relevant country.
- Do not leave the driver seat during the parking process.
- Pay close attention to the parking process and the traffic.
- Activate the turn signal yourself.
- In a hazardous situation, apply the brakes using the brake pedal.
- Do not park in parking spaces which do not have structural boundaries, e.g. near the water's edge or near inclines with no structural separation.

WARNING

The system only has limited reactions to quickly changing environmental conditions. This can result in collisions with other road users, damage to the vehicle and serious or fatal injuries.

- Do not use Park Assist Plus in flowing traffic at speeds of more than 80 km/h (50 mph).
- Always maintain a distance of at least one vehicle's length from junctions.
- Do not park on the opposite side of the road or across several lanes.

⚠ WARNING

During automatic parking, the vehicle may swing out or turn into oncoming traffic. Accidents and serious or fatal injuries could result.

- Pay close attention to the parking process and the traffic and brake the vehicle if necessary.

⚠ WARNING

If the road is icy, the parking process cannot be properly carried out and the vehicle may slide away. This could lead to accidents and damage to the vehicle.

- Do not use Park Assist Plus to park on slippery or icy roads.

ⓘ NOTICE

Park Assist Plus may suggest parking spaces that are not suitable for the parking process due to the absence of a boundary or presence of intrusive adjacent objects. This can result in vehicle damage.

- Do not park next to overhanging objects, e.g. cargo bays, parked trailers, or beneath hanging objects.
- Pay particular attention to the parking process in parking garages if the parking space is bordered by pillars.

📍 Park Assist Plus may not be available in some regions of the same country.

- Pay attention to the display in the Infotainment system.

Searching for parking spaces

📖 Please read the introductory information and heed the Warnings and Notice ⇒ ⚠ and ⓘ Safety instructions.

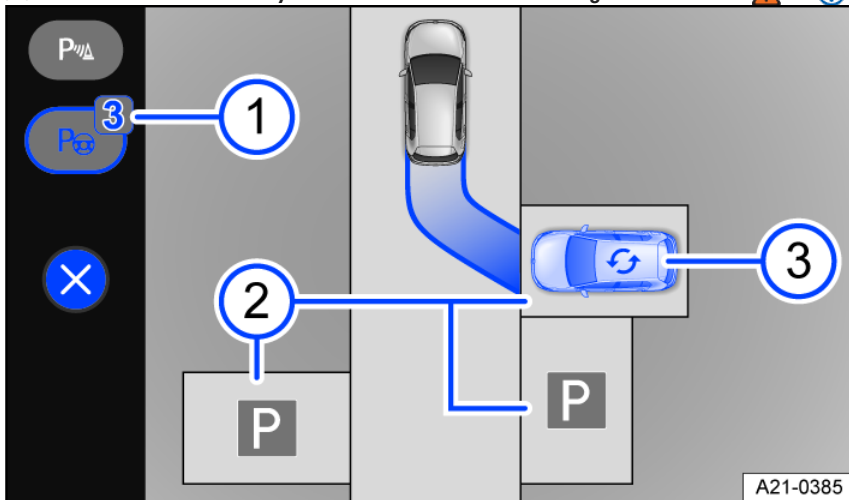

Fig. 102 Infotainment system: selecting a parking space (general example).

① Number of detected parking spaces.

② Possible parking modes:

- Cross parking driving forward.
- Cross parking in reverse.
- Parallel parking in reverse.

③ Change the preferred parking space (blue vehicle) and parking scenario.

Searching for parking spaces

1. Tap the  control for the parking menu.

2. While paying attention to traffic around your vehicle, drive slowly past a row of parked vehicles.

Park Assist Plus will automatically look for possible parking spaces.

Park Assist Plus will automatically select a parking space and display it as the preferred parking space (blue vehicle) in the Infotainment system [fig. 102](#) ② and ③.

The number of detected parking spaces is displayed on the  function key [fig. 102](#) ①.

3. Come to a complete stop and stop the vehicle with the brake pedal.



Changing parking spaces

If there are multiple parking spaces shown along the street in the Infotainment system, you can change the parking space.

1. Tap the desired parking space on the Infotainment system screen *fig. 102* .

A new preferred parking space (blue vehicle) is displayed.

Changing parking scenarios

If the parking scenario shown in the Infotainment system can be changed, the  symbol will be displayed above the parking space *fig. 102* .

1. Tap the  symbol.

A new parking scenario is displayed.

 **Park Assist Plus can be activated subsequently. If you drive past a suitable parking space, this will be indicated.**

Driving into parking spaces

 **Please read the introductory information and heed the Warnings and Notice  and  Safety instructions.**

Requirements

- ✓ Park Assist Plus has been activated.
- ✓ A parking space has been found and selected.
- ✓ The vehicle is in the starting position and its path is highlighted in blue in the Infotainment system.

Driving into parking spaces

1. Stop the vehicle with the brake pedal.
2. Tap **START** in the Infotainment system.
3. Release the steering wheel.
4. Release the brake.

The process of driving into a parking space starts.

5. Pay attention to the displays in the Infotainment system.

If necessary, Park Assist Plus can change the direction of travel independently.

6. At the end of a parking maneuver, always wait until Park Assist Plus has completed all rotational movements of the steering wheel in order to achieve an optimum parking result .

When the process of driving into a parking space is finished, a message will appear in the Infotainment system and a chime will sound.

The electronic parking brake is switched on.

7. Park the vehicle.

WARNING

During maneuvering, the steering wheel turns quickly. Interfering with the steering wheel can result in serious injury.

- Do not take over the steering until the system prompts you to do so.
- Take over the steering in dangerous situations.

Assistance during a parking attempt

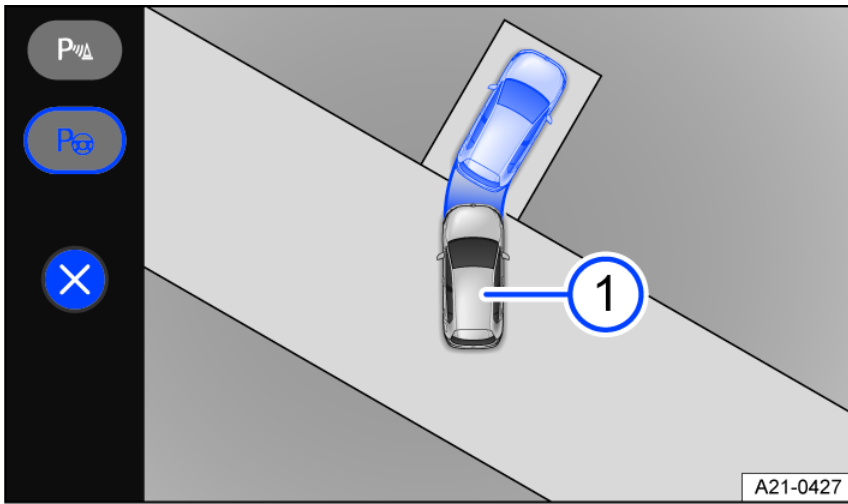

Fig. 103 Infotainment system: taking over the parking process from the driver.

① Vehicle “during” a parking attempt.

In difficult parking situations where an “attempt” at parking has already been made, Park Assist Plus can take over the parking process and guide the vehicle into the parking space *fig. 103*.

Requirements

- ✓ Park Assist Plus is not activated.
- ✓ The vehicle has been driven forward or backward into a parking space.

Reversing into a parking space

1. Stop the vehicle with the brake pedal.
In the Infotainment system, the **P+** function key indicates a detected parking space.
2. To switch to Park Assist Plus, tap **P+**.
3. Tap **START** to start the process of driving into a parking space.
4. Release the steering wheel.
5. Release the brake and follow all the actions for parking as described from item 5.

Drive the front of the vehicle into a parking space

1. Stop the vehicle with the brake pedal.
2. Tap the **P+ MENU** control for the parking menu.
3. Tap **START** in the Infotainment system to start the process of driving into a parking space.
4. Release the steering wheel.
5. Release the brake and follow all the actions for parking as described from item 5.

i You can reduce the speed when automatic parking by operating the brake pedal.

Exiting a parking space

📖 Please read the introductory information and heed the Warnings and Notice ⇒ **⚠** and **🚫** *Safety instructions*.

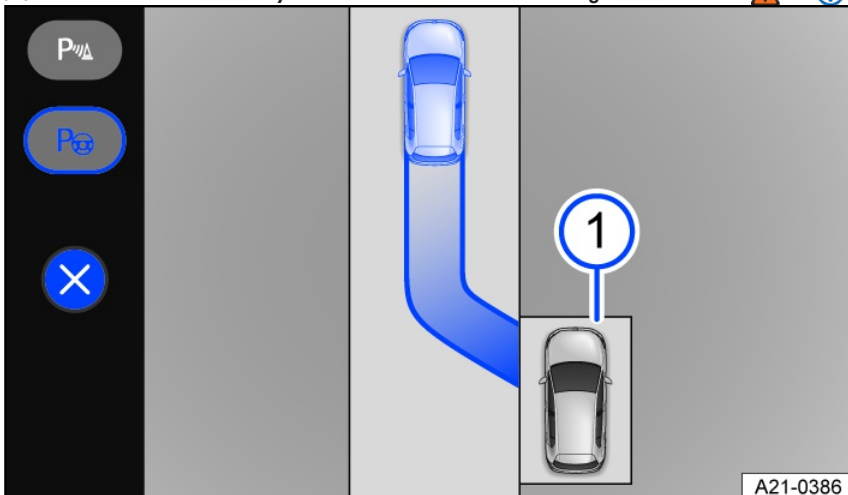

Fig. 104 Infotainment system: exiting procedure (general example).

① Vehicle in a parallel parking space.

1. Activate the vehicle's drive system.
2. Press and hold the brake pedal.
3. Activate Park Assist Plus.
4. Activate the turn signal for the side of the road where the vehicle should drive out of the parking space.
5. Tap **START** on the Infotainment system screen.
6. Release the steering wheel.
7. Release the brake.
8. Pay attention to the displays in the Infotainment system.
Park Assist Plus guides the vehicle out of the parking space.
A chime and a message from the Infotainment system signal that you have exited the parking space.
Control of the vehicle is transferred to the driver in neutral **N**.
9. Resume control of the vehicle and fully exit the parking space in the direction of travel ⇒ ⚠.

⚠ WARNING

When you maneuver out of a parking space, there is a danger of pulling into moving traffic. Accidents and serious or fatal injuries may occur.

- Only drive the vehicle out of the parking space when the traffic situation allows it.

⚠ WARNING

Park Assist Plus does not support pulling out of perpendicular parking spaces because obstacles in road traffic cannot be detected fully. There is a risk of accidents and serious injuries.

- Pull out of a perpendicular parking space yourself and pay attention to the traffic situation.

 The lane shown on the Infotainment system during a parking process is a general example. It does not correspond to the actual parking process with Park Assist Plus.

Park Assist Plus with memory function

Introduction

Park Assist (Park Assist Plus) with memory function helps drivers to park in parking spaces they frequently use, e.g. garages and driveways. The vehicle automatically maneuvers toward a parking space on a previously saved vehicle path.

The availability of Park Assist Plus with memory function depends on the vehicle equipment.

System function

Park Assist Plus with memory function is an extension of Park Assist (Park Assist Plus).

The parking system uses the front camera to detect the surrounding area and saves the vehicle path to the parking space over a maximum distance of approx. 50 m (approx. 164 ft). Once the parking process has been saved in the Infotainment system, the vehicle can automatically drive the route to or from the parking space.

The driver should continuously monitor the area surrounding the vehicle ⇒ ⚠.

Automatic braking support may intervene if there are obstacles in the vehicle's path or in dangerous situations.

 **Automatic, hands-free parking with Park Assist Plus with memory function may be prohibited or limited in some regions. Use Park Assist Plus with memory function only where permitted by legal provisions.**

Requirements

- ✓ There are geocoordinates available for the vehicle position.
- ✓ There is enough space to maneuver in. The vehicle may need to move a few meters to reach the calibrated vehicle path.

Driving with a trailer

Park Assist Plus with memory function cannot be activated if a trailer is connected to the electrical system.

If the trailer hitch was not installed at the factory, Park Assist Plus with memory function must be manually deactivated when towing a trailer.

WARNING

Park Assist Plus with memory function is not a replacement for the driver's attention and works only within the system limitations. Park Assist Plus with memory function cannot detect all driving situations and may not react, or may react with a delay, or may react in a way that is not desired. If you are careless, there is a risk of accidents, serious injuries and death.

- Always stay attentive and do not rely solely on the system. The driver is always responsible for control of the vehicle.
- Only drive the vehicle into the parking space if you possess a valid driving license.
- Abide by the traffic regulations in the relevant country.
- Do not leave the driver seat during the parking process.
- Pay close attention to the parking process and the traffic.
- In a hazardous situation, apply the brakes using the brake pedal.
- Do not use Park Assist with memory function for parking spaces which do not have structural boundaries, e.g. near the water's edge or near inclines with no structural separation.

WARNING

The system only has limited reactions to quickly changing environmental conditions. This can result in collisions with other road users, damage to the vehicle and serious or fatal injuries.

- Do not use Park Assist Plus in flowing traffic at speeds of more than 80 km/h (50 mph).
- Always maintain a distance of at least one vehicle's length from junctions.
- Do not park on the opposite side of the road or across several lanes.

WARNING

During automatic parking, the vehicle may swing out or turn into oncoming traffic. This may lead to vehicle damage and serious or fatal injuries.

- Pay close attention to the parking process and the traffic and brake the vehicle if necessary.

WARNING

If the road is icy, the parking process cannot be properly carried out and the vehicle may slide away. This may lead to accidents resulting vehicle damage and serious injuries.

- Do not use Park Assist Plus with memory function to park on slippery or icy roads.

 **Park Assist Plus may not be available in some regions of the same country.**

- Pay attention to the display in the Infotainment system.

Calibrating the parking process

 Please read the introductory information and heed the Warnings and Notice  and  Safety instructions.

Finding a suitable parking space

- ✓ The parking space is clearly visible and free of obstacles . Underground parking and parking garages are not suitable.
- ✓ The visibility is good, e.g. there is no heavy rain, fog or snow and it is not dark.

NOTICE

If the parking space does not have sufficient distance from curbs or other obstacles, the vehicle could be damaged during the parking process.

- Choose a parking space that is free of obstacles.
- Restart the parking process if Park Distance Control indicates an obstacle with a continuous tone when it is calibrating the maneuver.



Calibrating driving into a parking space

1. Drive the vehicle to the chosen parking space as usual.
2. Safely park the vehicle.
3. Save the process of driving into a parking space as a parking space in the Infotainment system.

Observe the following information to achieve an optimum parking result.

- Perform the process of driving into the parking space as evenly as possible.
- Avoid correcting the vehicle path on the last few meters to the parking space.
- Do not turn the steering wheel all the way, do not turn it too quickly and avoid changing direction too often.

Version 1: saving a parking space in the menu of the Park Assist Plus with memory function

1. Tap the  control for the parking menu.
2. Tap  for Park Assist Plus with memory function in the Infotainment system.
3. Tap .
4. Name the function key, assign it your preferred symbol and confirm.

A new parking space is saved in the menu.

Version 2: saving a parking space in the vehicle's exit menu

When leaving the vehicle, the exit menu is displayed in the Infotainment system.

1. Tap .



The process for driving into the parking space is saved with the geocoordinates as an unnamed parking space.

 **To replace the geocoordinates with a parking space name, edit the parking space in the parking system menu.**

Calibrating the exiting procedure

This function depends on the vehicle equipment.

- ✓ The vehicle is in the position saved for a parking space with a parking procedure in the Infotainment system.

1. Switch on the ignition and ensure that the vehicle is drive-ready.
2. Tap the  control for the parking menu.
3. Tap  for Park Assist Plus with memory function in the Infotainment system.
4. Select the saved parking space.

A message is displayed in the Infotainment system.

5. Drive the vehicle out of the parking space.
6. Confirm the completion of the exiting procedure with the function key in the Infotainment system.

The exiting procedure is also saved on the current parking space in the menu.

 **The calibration run will be ended if the vehicle is driven out of the parking space at excess speed or for too long a distance.**

Recalibrating the parking process for a saved parking space

If you would like to calibrate the parking process again (e.g. to improve the parking result or to approach from a different direction of travel), you should first delete the saved parking space from the menu of Park Assist Plus with memory function.



 **When a saved parking space is deleted, the processes for driving into and out of the space will always be deleted too.**

Displaying and editing parking spaces

 Please read the introductory information and heed the Warnings and Notice ⇒  and  **Safety instructions.**

Opening the menu

Up to five saved parking processes are displayed as favorites in the menu for Park Assist Plus with memory function.

1. Tap the  control for the parking menu.
2. Tap  for Park Assist Plus with memory function in the Infotainment system.

Managing parking spaces

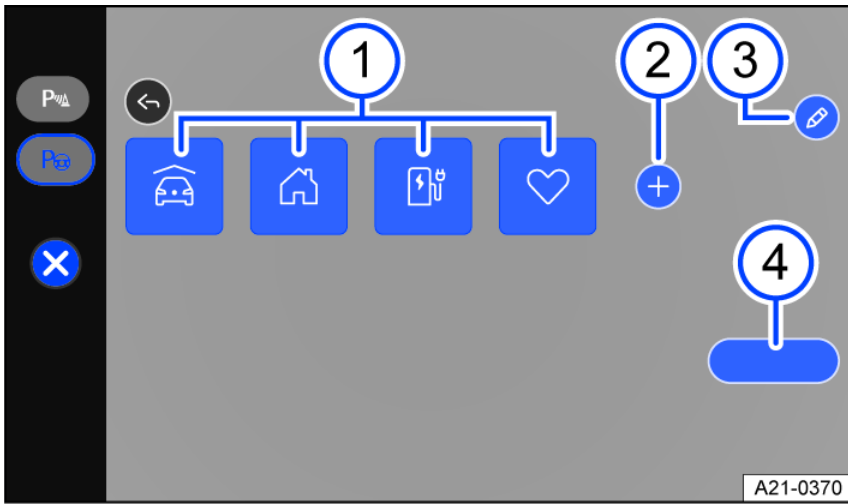



Fig. 105 Infotainment system: menu for Park Assist Plus with memory function.

- ① Maximum of five saved parking spaces.
- ② Add last parking process.
- ③ Edit saved parking spaces.
- ④ Start the parking process.

Editing, sorting and deleting parking spaces

1. Tap  *fig. 105* .

All saved parking spaces can be edited.

2. To rename a parking space or assign it a new symbol, tap  on the parking space symbol.

Or: to sort the parking spaces again, press and hold the function key for a parking space and push it to its new position.

Or: to delete a parking space, tap  on the parking space symbol.

To delete all parking spaces, tap  on the function key for all parking spaces.

Status of saved parking spaces

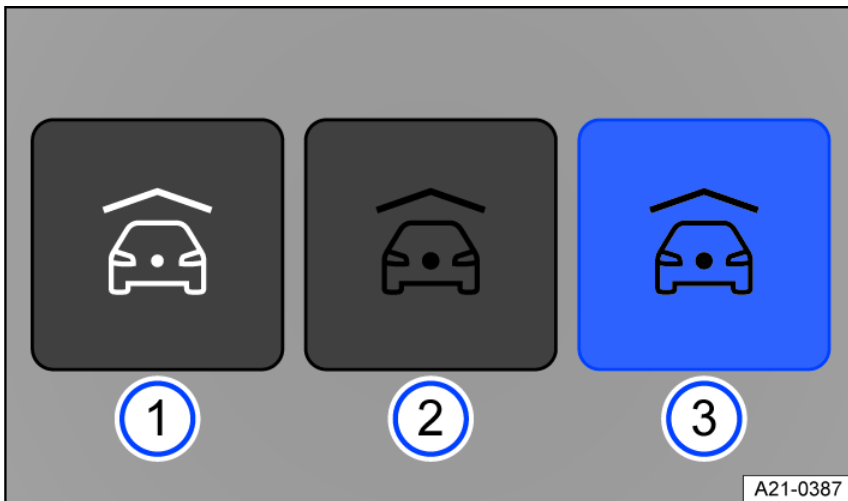

Fig. 106 Infotainment system: parking spaces without navigation.

- ① Parking space is not available.
- ② Parking space is available.
- ③ Automatic parking process selected.



Fig. 107 Infotainment system: parking space with route guidance for navigation (depending on the country).

Driving into or out of a parking space

📖 Please read the introductory information and heed the Warnings and Notice ⇒ ⚠️ and ⚠️ Safety instructions.

Driving into parking spaces

When the vehicle is driven into the vicinity of a saved parking space, the parking system automatically offers a parking process in the Infotainment system.

- Stop as close as possible to the saved vehicle path, deviating by no more than around 1 m (around 3.28 ft).
- Always drive into the starting position from the same direction of travel.

📌 If visibility is very poor, there may be restrictions to driving into and out of parking spaces, e.g. when it is dark or snowing.

Variant 1: menu for Park Assist Plus with memory function

1. Bring the vehicle to a stop using the brake pedal.
2. If necessary, tap the available parking space in the parking system menu in the Infotainment system.

The function key is highlighted in blue.

3. Tap **START**.

4. Let go of the steering wheel and release the brake pedal.

The parking system starts the process of driving into a parking space ⇒ ⚠️.

5. At the end of a parking maneuver, always wait until Park Assist Plus with memory function has completed all rotational movements of the steering wheel in order to achieve an optimum parking result ⇒ ⚠️.

When the process of driving into a parking space is finished, a message will appear in the Infotainment system and a chime will sound.

The electronic parking brake is switched on.

6. Park the vehicle.

Variant 2: Navigation in the Infotainment system

A message will appear in the Infotainment system as soon as the destination has been reached.

1. Bring the vehicle to a stop using the brake pedal.

2. Tap **START** in the message.

3. Release the steering wheel.

4. Release the brake.

5. Pay attention to the displays in the Infotainment system.

The parking system starts the process of driving into a parking space ⇒ ⚠️.

6. For variant 1, follow all the actions as described above from item 5.

⚠️ WARNING

During maneuvering, the steering wheel turns quickly. Interfering with the steering wheel can result in serious injury.

- Do not take over the steering until the system prompts you to do so.
- Take over the steering in dangerous situations.

! NOTICE

While the vehicle is automatically maneuvering in the saved vehicle path, it could be damaged by surrounding obstacles.

- Make sure that there is a sufficient distance to obstacles because the vehicle will steer and make corrections.
- Brake the vehicle if necessary.

Exiting a parking space

This function depends on the vehicle equipment.

1. Switch on the ignition and ensure that the vehicle is drive-ready.
2. Open the parking system menu in the Infotainment system.
3. Tap the available parking space with the saved exiting procedure.

The function key is highlighted in blue.

4. Stop the vehicle with the brake pedal.
5. Tap **START**.
6. Release the steering wheel.
7. Release the brake.
8. Pay attention to the displays in the Infotainment system.
The parking system starts the exiting procedure.
9. At the end of a parking maneuver, always wait until Park Assist Plus with memory function has completed all rotational movements of the steering wheel in order to achieve an optimum parking result ⇒ ⚠.
10. Resume control of the vehicle ⇒ ⚠.

! WARNING

When you maneuver out of a parking space, there is a danger of pulling into moving traffic. Accidents and serious or fatal injuries may occur.

- Only drive the vehicle out of the parking space when the traffic situation allows it.

Navigation to a parking space as a destination

📖 Please read the introductory information and heed the Warnings and Notice ⇒ ⚠ and ! Safety instructions.

Which parking spaces are available as navigation destinations?

Saved parking spaces with the navigation symbol 📍 can be transferred to the navigation system as a destination. The function depends on the country.

Starting route guidance

1. To select a destination, tap the parking space with the navigation symbol 📍 in the parking system menu in the Infotainment system.
2. Confirm the message in the Infotainment system.

Route guidance will start and the parking menu will close.

Or: follow the actions for exiting a parking space using the parking system.

3. Once the vehicle has arrived at the destination, note the message in the Infotainment system.
Park Assist Plus with memory function is ready to automatically drive the vehicle into the parking space.

Rear Traffic Alert



Rear Traffic Alert monitors the cross traffic when reversing out of a space or maneuvering.

! WARNING

Rear Traffic Alert is not a replacement for the driver's attention and works only within the system limitations. All approaching objects, e.g. pedestrians or objects approaching quickly, may not be detected. If you do not take care, there is a risk of accidents and serious injuries.

- Always stay attentive and do not rely solely on the system. The driver is always responsible for control of the vehicle.
- Pay attention to the traffic situation and the vehicle environment.
- React quickly to the visual warnings and warning chimes of the Rear Traffic Alert system.

Switching on and off

1. Tap the  control for the parking menu.
2. Tap the  function key in the Infotainment system.
3. Switch Rear Traffic Alert on or off.

System function

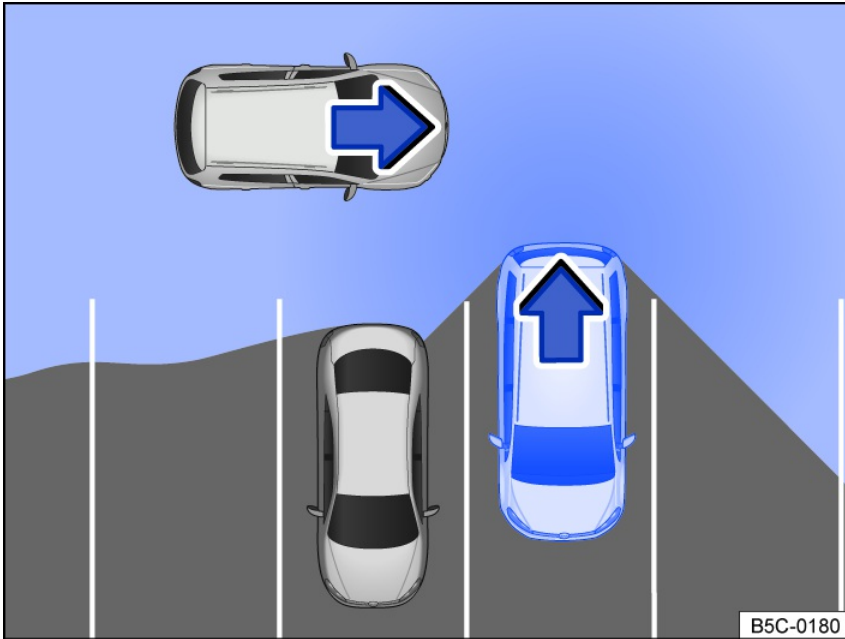

Fig. 108 Rear Traffic Alert, general example: monitored area around the vehicle that is exiting a parking space.

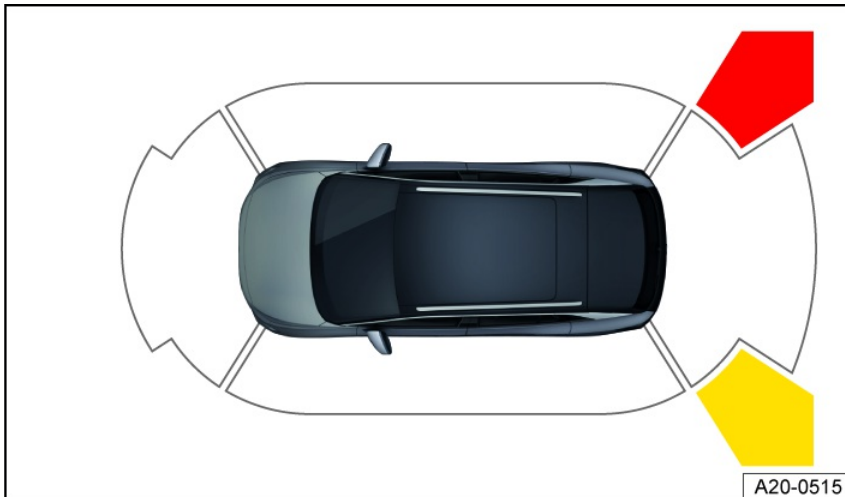

Fig. 109 Infotainment system: Rear Traffic Alert display.

The Rear Traffic Alert functions with radar sensors in the rear bumper.

The system detects approaching or moving objects in the surrounding area to the rear and to the side and warns the driver if there is an obstacle [fig. 108](#), ⇒ 

If there is an obstacle, a warning signal will sound and there will be a colored display of the area of the obstacle in the Infotainment system [fig. 109](#).

If the driver does not respond, automatic braking support may kick in.

Automatic braking intervention by Rear Traffic Alert.

1. Press the brake pedal to bring the vehicle to a standstill.

Malfunction

If Rear Traffic Alert is malfunctioning, the following indicator light comes on in the Volkswagen Digital Cockpit:

Rear Traffic Alert malfunction (for example, dirty sensors or system error).

Driving with a trailer

Rear Traffic Alert cannot be activated if a trailer is connected to the electrical system.

If the trailer hitch was not installed at the factory, Rear Traffic Alert must be manually deactivated when towing a trailer.

Braking assistance systems

Information about braking assistance systems

Braking assistance systems can assist the driver in critical driving and braking situations. The driver is always responsible for safe driving ⇒ ⚠.

- If a braking assistance system is regulating, continue braking with the necessary force.
- If necessary, steer the vehicle.

⚠ WARNING

Braking assistance systems cannot replace the driver's attention and can only operate within the limitations of the system. Fast driving on icy, slippery, or wet roads, as well as following the vehicle ahead too closely, may impair the vehicle stability and cause you to lose control of the vehicle. If you are careless, there is a risk of accidents, serious injuries and death.

- Always stay attentive and do not rely solely on the system. The driver is always responsible for control of the vehicle.
 - Always adapt your speed and driving style to the visibility, weather, road and traffic conditions. Do not take any risks.
 - Always keep the footwell beneath the pedals clear so that the brake pedal is unobstructed and can move freely.
 - Always use suitable tires, as driving stability depends on the tires' ability to grip the road.
-
- ESC, ABS and ASR only function correctly when all four wheels have the intended tires ⇒ ⚠.
 - If the ABS malfunctions, the ESC, ASR and EDS also fail.

When the ignition is switched on, the condition of the braking functions is automatically checked. The indicator lights will come on briefly and then turn off. If an indicator light remains on permanently, there is a malfunction. Contact an authorized Volkswagen dealer or authorized Volkswagen Service Facility immediately. Volkswagen recommends contacting an authorized Volkswagen dealer or authorized Volkswagen Service Facility.

⚠ WARNING

The effectiveness of the ESC may be reduced considerably if other components and systems that affect driving dynamics have not been maintained correctly or are malfunctioning. This applies in particular to changes made to the suspension and any non-approved wheel and tire combinations. Accidents and serious or fatal injuries could result.

- Ensure that conversion and modifications to the vehicle are only performed by an authorized Volkswagen dealer or authorized Volkswagen Service Facility. Volkswagen recommends contacting an authorized Volkswagen dealer or authorized Volkswagen Service Facility.
- Always use suitable tires, as driving stability depends on the tires' ability to grip the road.

Electronic Stability Control (ESC)



ESC is regulating the vehicle to reduce the risk of skidding and improve driving stability ⇒ ⚠. The indicator light flashes yellow.

Anti-Slip Regulation (ASR)



ASR is regulating the vehicle to reduce the risk of the wheels spinning. The indicator light flashes yellow.

ASR reduces drive power at wheels that are spinning and adapts the drive power to the road conditions. ASR makes it easier to start, accelerate, and drive up hills ⇒ ⚠.

Anti-Lock Braking System (ABS)

ABS prevents the wheels from locking during braking so that the vehicle can be steered ⇒ ⚠.

Brake Assist System (BAS)

BAS can help to reduce the vehicle braking distance. BAS increases braking power when the driver presses the brake pedal quickly in emergency situations ⇒ ⚠.

Electronic Differential Lock (EDL and XDL)

EDS automatically applies the brakes to a wheel that starts spinning and transfers the drive power to the other driving wheels.

XDS is an extension of the electronic differential lock, and improves traction with braking support to help keep the vehicle in its lane.

Multi Collision Brake

The Automatic Post-Collision Braking System automatically brakes the vehicle if the airbag control module has detected a collision in an accident situation.

Requirements for automatic braking:

- ✓ The driver does not press the accelerator pedal.

Electronic braking distribution (EBD)

The electronic braking distribution (EBD) regulates the braking force between the front axle and the rear axle, even outside of ABS regulation. Overbraking of the rear axle is avoided and the vehicle remains stable when braking.

Electromechanical brake booster (eBB)

The electromechanical brake booster (eBB) supports the foot pressure only when the ignition is switched on and enhances the pressure applied to the brake pedal by the driver ⇒ . In case of braking support by a driver assistance system, such as during control by the ACC or during emergency braking, the brake pedal may move itself.

After switching off the ignition, braking assistance will be gradually reduced. If the vehicle is still being held by the brake pedal, text messages will appear on the instrument cluster display. Brake support is limited in this case.

Secure the stationary vehicle against rolling away → page , *Parking*.

WARNING

Driving without the brake booster or when the brake booster's system function is limited can increase the braking distance significantly. This may lead to accidents resulting in serious or fatal injuries.

- Press the brake pedal harder if the brake booster does not work or the vehicle is being towed.
- Always keep the footwell beneath the pedals clear so that the brake pedal is unobstructed and can move freely.

Brake blending

Brake blending takes control between the electric motor braking efficiency during energy recuperation and the driver's mechanical braking.

Switching ASR Sport and ESC Sport on and off

On vehicles with all-wheel drive (4MOTION), the ESC brake regulation system can be switched to a sport mode.

Driving situations

In order to avoid risks, the brake systems should not be switched off under normal conditions ⇒ .

WARNING

When ASR is restricted or ESC Sport is switched on, the risk of the vehicle swerving is significantly higher. The vehicle can be difficult for inexperienced drivers to handle at high speeds. Accidents and serious or fatal injuries could result.

- Only switch on ESC Sport if you are driving on a closed track and are experienced in sporty driving.
- Do not take any risks.

Switching on and off

1. Open the vehicle settings of the Infotainment system ⇒ *Vehicle settings menu*.
2. Open the Vehicle menu.
3. Open the Exterior menu.
4. Open the Brakes menu.
5. Activate the function in the ESC system drop-down list.

If the setting is no longer being used, you should completely switch off the braking assistance system again ⇒ .

ASR Sport

Vehicles with rear-wheel drive: It can be helpful to switch on ASR Sport when the vehicle is driven on loose ground or when "rocking" the vehicle out of place because it is stuck ⇒ .

This function is available via the ASR off setting in the ESC system drop-down list in the Infotainment system.



ASR Sport switched on. The yellow indicator light turns on.

ESC Sport

The function assists with sporty driving. The ESC intervenes later to stabilize the vehicle, e.g. during fast cornering ⇒ .



ESC Sport is switched on. The yellow indicator light turns on.

Troubleshooting

BRAKE Electromechanical brake servo failure



Do not continue driving!

The red warning light turns on.

A message is displayed if necessary. Press the brake pedal harder, as the lack of braking assistance will increase the braking distance.

1. Contact an authorized Volkswagen dealer or authorized Volkswagen Service Facility for assistance.

Electromechanical brake servo faulty

The yellow indicator light turns on.

A message is displayed for a few seconds.

The brake pedal might pulse when pressed. Press the brake pedal harder, because the reduced braking assistance will increase the braking distance.

1. Contact an authorized Volkswagen dealer or authorized Volkswagen Service Facility. Volkswagen recommends contacting an authorized Volkswagen dealer or authorized Volkswagen Service Facility.

ABS **ABS failure or malfunction**

The yellow indicator light turns on.

1. Contact an authorized Volkswagen dealer or authorized Volkswagen Service Facility. Volkswagen recommends contacting an authorized Volkswagen dealer or authorized Volkswagen Service Facility.

The vehicle can be braked without ABS.

ESC malfunction

The yellow indicator light turns on. ESC has been switched off.

There is a fault or malfunction.

1. Switch the ignition off and on.
2. Drive a short distance at a speed of approximately 15 km/h (approx. 9 mph) to 20 km/h (approx. 12 mph).
3. If the  indicator light stays on, contact a suitably qualified professional. Volkswagen recommends contacting an authorized Volkswagen dealer or authorized Volkswagen Service Facility.

Noises in the braking assistance systems

When the braking assistance systems are actively regulating, the brake pedal may move or noises may occur.

1. Continue braking with the necessary force and, if necessary, steer the vehicle.

WARNING

If the **BRAKE** brake warning light comes on together with the **ABS** indicator light, the regulating function of the ABS could be malfunctioning. This can cause the rear wheels to lock when braking. This could cause you to lose control of the vehicle and lead to accidents with serious or fatal injuries.

- Drive at low speed to the nearest authorized Volkswagen dealer or authorized Volkswagen Service Facility to have the brake system checked. Volkswagen recommends contacting an authorized Volkswagen dealer or authorized Volkswagen Service Facility.
- Avoid sudden braking or driving maneuvers.

WARNING

If the **ABS** indicator light does not turn off, or comes on during the journey, the ABS is not working correctly. The vehicle can only be stopped with the normal brakes. If the ABS is restricted, this may lead to accidents causing damage to the vehicle and serious or fatal injuries.

- Contact an authorized Volkswagen dealer or authorized Volkswagen Service Facility. Volkswagen recommends contacting an authorized Volkswagen dealer or authorized Volkswagen Service Facility.

Practical equipment

Storage compartments

Introduction

WARNING

Loose objects can be thrown around the inside of the vehicle during sudden driving or braking maneuvers. This can cause a loss of vehicle control, and can cause accidents and serious or fatal injuries.

- Store objects in only closed storage compartments.
- Always keep the storage compartments closed while driving.
- Only hang lightweight clothing, up to a maximum of 2.5 kg (approximately 5.5 lbs), from the coat hooks in the vehicle.
- Never leave heavy, hard or sharp objects in clothing pockets.

WARNING

If the glove compartment is open while you are driving, objects may be flung into the vehicle interior. This can cause a loss of vehicle control, and can cause accidents and serious or fatal injuries.

- Always keep the glove compartment closed while driving.

WARNING

Lighters in the vehicle can become damaged or ignite unintentionally, for example due to high surface temperatures. This can cause severe burns and vehicle damage.

- Before closing compartments or storage areas, always make sure that there are no cigarette lighters near the sections that will be closing.
- Never place lighters in compartments, in storage areas, or on other surfaces in the vehicle.

WARNING

Incorrect usage of the cup holders can cause injuries. Hot beverages in the cup holders could spill and cause burns while driving, during sudden braking maneuvers, or in collisions.

- Do not place hot beverages in the cup holders.
- Take care that only suitably sized drinks are stored in the cup holder. Drinks must always be steady and secure in the cup holder.

WARNING

Closed beverage bottles can explode from heat and burst from frost and cause severe injuries.

- Never leave closed beverage bottles in an extremely hot or extremely cold vehicle.

NOTICE

Objects stored in the vehicle may be damaged by strong sunlight or the effects of heat or cold or cause damage to the vehicle.

- Never leave any objects, groceries, or medications that are sensitive to temperature in the vehicle interior.
- Bear in mind that objects made from transparent materials, e.g. transparent suction cups on door windows, can concentrate sunlight.

Sockets

Introduction

Electrical devices can be connected to the sockets in the vehicle.

The 12 V socket only works when the ignition is switched on.

WARNING

Using sockets and connected electrical devices incorrectly can cause fires and serious injuries or death.

- If the electrical devices become too warm, turn off the devices immediately and disconnect them.
- Be aware that sockets and devices connected to them may still be used, e.g. by children in the vehicle, when the ignition is switched off.

NOTICE

Electrical devices that are unsuitable, not permitted, or connected incorrectly may cause damage to the vehicle or electronics. Do not use any malfunctioning devices.

- Never connect electrical devices that provide power, such as solar panels or battery chargers, to the 12 V socket in order to charge the 12 V vehicle battery.
- Only use electrical devices that have been tested for compliance with the applicable directives for electromagnetic compatibility.
- Do not use any malfunctioning devices.
- To reduce the risk of damage from voltage fluctuations, turn electrical devices off before switching the ignition on or off, and before engaging the vehicle's drive-readiness.
- Refer to the operating instructions for the electrical devices.

NOTICE

The vehicle electrical system can be damaged when the maximum load is exceeded.

- Never connect electrical devices that draw more than the specified load of a 12 V socket.

The 12-V vehicle battery will discharge when the ignition and electrical devices are switched on and the vehicle's drive system is running.

Unshielded devices can cause malfunctions in the radio, the Infotainment system and in the vehicle electronics, depending on the vehicle equipment.

Sockets in the vehicle

Please read the introductory information and heed the Warnings and Notice ⇒ and Introduction.

Do not exceed the maximum power of the sockets. The power draw of the external devices is indicated on their identification labels.

12 V socket



Fig. 110 In the luggage compartment on the left-hand side: folding 12-volt socket (general example).

The total continuous output of all 12 V sockets in the vehicle is 120 watts ⇒ Introduction.

The maximum power of a 12 V socket in the vehicle when the vehicle is drive-ready totals 180 watts.

NOTICE

Using 12 V sockets for too long at maximum power can cause the fuse to blow.

- Never use 12 V sockets at their maximum power for longer than 10 minutes.
- Only ever use a single 12 V socket at maximum power.

Charging Options for Mobile Devices

📖 Please read the introductory information and heed the Warnings and Notice ⇒ ⚠️ and 🚫 Introduction.

You can charge mobile devices in the vehicle either wirelessly or by using the built-in USB-C connectors.

Charging with USB-C Connectors

The vehicle may contain the following USB-C ports:

🔌 Symbol for a USB port for data transmission and charging. 🔌 Symbol for a USB port for charging only.

Available Charging Power

Voltages up to 20 V are provided via the USB port, which enables up to 45 W charging power.

Depending on the vehicle equipment, the following charging profiles may be supported by the USB ports:

- Legacy charging (2.5 W).
- BC1.2 (7.5 W).
- USB-C charging (15 W).
- USB power delivery (up to 45 W).

The actual charging power of the connected device depends on the following aspects:

- Supported charging profiles.
- Device charge level.
- Device temperature.
- Charging cable used.

📖 For double USB ports, the charging power can be split between both ports.

Wireless charging function



Fig. 111 General example: storage compartment with a holder for wireless charging in the center console.

The wireless charging function depends on the vehicle equipment and is not available in all countries.

The wireless charging function uses electromagnetic induction to transfer energy wirelessly over short distances. To use this function, you need a suitable Qi-certified cell phone. To find out whether a cell phone supports the Qi standard, see the cell phone operating instructions. New technologies might not be compatible with the wireless charging function. The manufacturer of the cell phone can offer further information regarding compatibility.

The maximum charging power is 5 watts.

The storage compartment *fig. 111* for wireless charging is located in the center console.

In some vehicles, the charging area *fig. 111* bears a phone symbol, which indicates the center position for the wireless charging function. The symbol on the charging area may look different in some vehicles.

Only a single Qi-certified cell phone without a protective case and with maximum dimensions (width x length) of 80 mm x 140 mm (approx. 3 in x 6 in) should ever be placed flat on the storage compartment.

Qi-certified cell phones with larger dimensions cannot be charged wirelessly.

Wireless Cell Phone Charging

Requirements

✓ You must have a suitable cell phone that does not exceed the maximum dimensions and supports the Qi standard.

1. Before charging, remove any foreign objects with metal components, such as coins, from the storage compartment and follow the cell phone operating instructions.
2. Open the holder in the storage compartment and position the cell phone, without a protective case and with the display facing forward, between the holder and the charging area at the center of the charging area.

The charging process starts automatically.

The Infotainment system informs you when the charging process is starting and, if necessary, if there are any foreign objects with metal components in the storage compartment. Remove foreign objects immediately.

Your Cell Phone Is Not Recognized

If a cell phone is not placed on the charging area correctly or if it is too large, it may not be detected correctly or may not be detected at all. The Infotainment system may notify you of a foreign object in the storage compartment.

If a suitable cell phone is used and its position is corrected, the fault may be eliminated. Remove your cell phone and place it correctly in the storage compartment for the wireless charging function.

WARNING

Notifications on the cell phone display may distract the driver. This can result in an accident with serious or fatal injuries.

- Place only a single, suitable and Qi-certified (if necessary) cell phone without a protective case and with maximum dimensions (width x length) of 80 mm x 140 mm (approx. 3 in x 6 in), in accordance with the specifications, on the shelf in the storage compartment.
- Remove items that prevent the cover from closing.
- Always keep the cover closed while driving.

WARNING

Metal objects on the shelf can become very hot. This may cause burns or a fire.

- Do not place metal objects or objects with metal components on the wireless charging shelf.

NOTICE

If any ID cards, bank cards or credit cards with a magnetic strip or chip are placed on the wireless charging shelf, the data saved on the magnetic strip or chip could be damaged or become unusable.

- Do not place any ID cards, bank cards or credit cards with a magnetic strip or chip on the wireless charging shelf.

Data transmission

Cyber security

Cyber security describes measures that reduce the risk of illegal access to vehicle functions, data and control modules caused by malware or an Internet attack.

What are connectivity components?

Control modules for data transmission, interfaces, media and diagnostic connections are connectivity components, through which information and data can be exchanged between the vehicle and external devices or the Internet.

Connectivity components are the key points for cyber security. Connectivity components are also equipped with security mechanisms that minimize the risk of unauthorized access to vehicle systems.

The following connectivity components may not be available in all vehicles:

- Diagnostic connection port
- Control module with installed eSIM card.
- Mobile phone interface
- App-Connect.
- NFC radio technology.
- Bluetooth® interface.
- USB port.

Security mechanisms

Software and security mechanisms available in the vehicle undergo continuous development. Similar to computers or operating systems on cell phones, software and security mechanisms in the vehicle may also be updated at various times.

Generally, system updates improve the security, stability, and processing speeds of the vehicle systems in vehicles.

WARNING

In spite of the integrated security mechanisms, malware can cause malfunctions in control modules and the vehicle. Malfunctions may cause serious accidents and fatal injuries.

- If the vehicle works or reacts differently to normal, reduce your speed in a controlled manner.
- Contact qualified professionals for assistance. Volkswagen recommends contacting an authorized Volkswagen dealer or authorized Volkswagen Service Facility.

 **Malware can also access data and information that are stored in the control modules, in the Infotainment system, on connected data carriers, and in paired cell phones.**

Minimizing risks

You can actively help to reduce the risk of unauthorized access to vehicle systems and functions by following these guidelines:

- Only use data carriers, Bluetooth devices and cell phones in the vehicle that do not contain any manipulated data or malware.
- Install the system updates provided by Volkswagen immediately ⇒ [System update](#).
- Only have the vehicle repaired and serviced by suitably qualified professionals. Volkswagen recommends contacting an authorized Volkswagen dealer or authorized Volkswagen Service Facility.

WARNING

Computers, data carriers and cell phones that are connected to the Internet or are used in public or private networks can be infected by viruses through manipulated data and by malware. This may cause a complete loss of data or damage to computers, data carriers or cell phones.

- Protect computers, data carriers and cell phones with a suitable antivirus program and by taking generally recognized precautions.
- Regularly update the antivirus program using the supplied system updates or upgrades provided by the vendor.

System update

Introduction

The system update is a preventative measure, for example, to protect from malware and to optimize functionality.

A system update can be used to update the software of control modules in the vehicle.

Depending on the vehicle and country, this can be performed in two ways:

- System update by a suitably qualified authorized Volkswagen dealer or authorized Volkswagen Service Facility.
- System update by Volkswagen via an Over-the-Air Update.

How do I recognize an upcoming system update?

When switched on, the Infotainment system displays an upcoming system update.

If multiple system updates are available for the vehicle at a given time, one system update must be successfully completed before the next system update can be carried out.

WARNING

In very occasional circumstances, there is the possibility that a control module may no longer work properly after a system update. Malfunctions in a control module and the vehicle can cause serious accidents and fatal injuries.

- If the vehicle works or reacts differently to normal while driving, reduce your speed in a controlled manner.
- Contact qualified professionals for assistance. Volkswagen recommends contacting an authorized Volkswagen dealer or authorized Volkswagen Service Facility.

WARNING

If the digital instrument cluster malfunctions after a system update, no instruments, warning lights, symbols or messages can be displayed. Driving with a malfunctioning instrument cluster can lead to serious accidents and fatal injuries.

- Do not use the vehicle. Contact Volkswagen Customer Care.

 A measure (e.g. engine tuning) to increase performance or efficiency that has not been undertaken by Volkswagen may be undone when you update the system.

 Depending on the vehicle equipment, "release notes" that describe the changes to the vehicle status may be displayed once before or after a system update. The release notes cannot be viewed again after this.

Prerequisites for a system update

 Please read the introductory information and heed the Warnings and Notice ⇒  Introduction.

The following prerequisites must be met so that the system update download can take place and you can install the software.

- ✓ The "system update" function is available in your country.
- ✓ You have assigned the vehicle to your active Volkswagen user account.
- ✓ A primary user has been set up.
- ✓ The vehicle is in an area with enough mobile reception.
- ✓ The 12-volt vehicle battery is sufficiently charged.

Download and software installation

 Please read the introductory information and heed the Warnings and Notice ⇒  Introduction.

Download

A system update is automatically downloaded without a prior message and is possible even while driving.

 The download duration depends on the network quality, file size and type of system update.

 The download can be interrupted at any time and then continued if required by switching on the ignition.

Prerequisites for download

- ✓ The requirements for the system update have been met ⇒ Prerequisites for a system update .
- ✓ An Internet connection is possible via the integrated eSIM card at the vehicle's current location ⇒ Parking.
- ✓ The vehicle is parked safely in accordance with legal requirements and local conditions ⇒ Parking.

Software installation

Select a time for the software installation of a system update at which neither you nor any other person needs to use the vehicle.

WARNING

Control units are deactivated and do not operate for the duration of any software installation. Driving with deactivated or non-functioning control units can lead to accidents and fatal injuries.

- Never operate your vehicle during a software installation.

Functional limitations during software installation

During software installation, control units, functions and displays will not be available. Do not use the vehicle during this process and do not operate the Infotainment system.

- The vehicle's drive system is blocked from being activated by the system.
- The high-voltage battery is not charged.
- The diagnostic connection port is deactivated.
- Control modules, the central processor, functions and displays are not available. Do not use the vehicle during this process.

Following the software installation

After the software installation and before establishing drive-ready mode, read the message regarding completion of the installation in the Infotainment system and instrument cluster. The vehicle takes up to a minute to display the system update status.

- The vehicle's drive system can be activated following the successful software installation.
- If the software installation is unsuccessful: ⇒ [Troubleshooting](#).

Troubleshooting

 Please read the introductory information and heed the Warnings and Notice ⇒  [Introduction](#).

Software installation is unsuccessful

- If the software installation was not successful, a corresponding error message appears in the Infotainment system or instrument cluster. Take note of corresponding messages and warning notifications.
- If there was a critical installation error, control modules may no longer function or not function correctly. Functions and displays will not be available until the error is rectified. Do not use the vehicle. If this is the case, contact Volkswagen Customer Care.

Should I allow the system update?

For your own benefit, you should run the system update as soon as possible. If the system update is ignored multiple times by the driver, you must see a suitably qualified professional for advice. Volkswagen recommends contacting an authorized Volkswagen dealer or authorized Volkswagen Service Facility.

Can I interrupt the software installation?

No, this is not possible.

What happens if the software installation is interrupted?

If a software installation is interrupted, e.g. due to damage to the vehicle's electrical system, control modules cannot be updated and may be damaged by the incomplete software installation.

Wired and wireless connections

Introduction

Some external devices can be connected to the Infotainment system using the wired and wireless connections in the vehicle, if available.

The type and number of wired and wireless connections depends on the vehicle equipment and the country. The connections may differ within a model line or in a model with optional equipment.

In wired connections, only use the original connecting cable that belongs to the device or the connecting cable that was placed in the vehicle at the factory, if available.

If the plug on the connector cable cannot be inserted, check the position and the connections.

NOTICE

Using unsuitable or damaged connector cables or inserting the plug on the connector cables in the wrong position or too forcefully may cause malfunctions and damage to devices.

- Only use suitable and undamaged connector cables.
- Hold the plug on the connector cable in the correct position and insert it into the intended socket while pressing lightly. Pressing strongly can damage the device connection and the plug on the connector cable.
- The connector cable must not be pinched or bent sharply.

 If a connected device is not recognized, disconnect all connected devices and then reconnect the device. Check the function of the connector cable used, if necessary.

 If malfunctions occur in a connected device, restart the device. This sometimes fixes the error.

USB port

 Please read the introductory information and heed the Warnings and Notice ⇒ [Introduction](#).

Using the USB port, you can transfer data and charge devices or only charge devices.

USB-C port

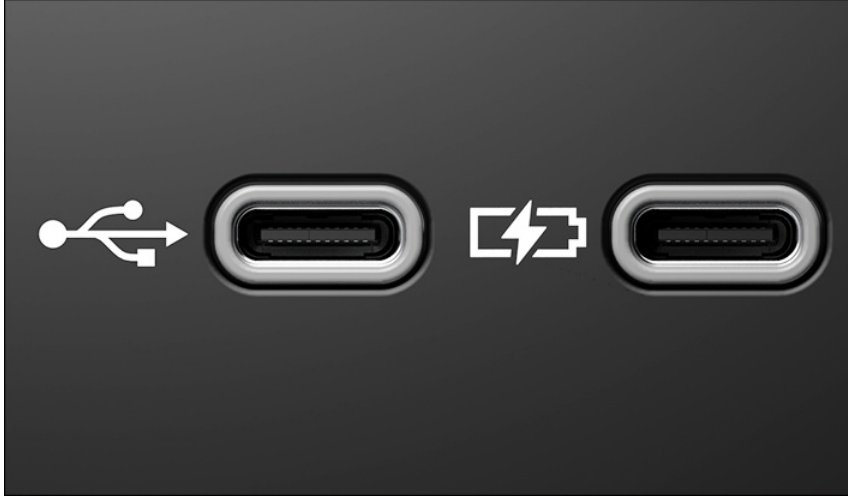

Fig. 112 USB-C connection in the vehicle (general example).

The vehicle may contain the following USB-C ports:

 Symbol for a USB port for data transmission and charging.  Symbol for a USB port for charging only.

You can find information about charging options and charging power here ⇒ [Charging Options for Mobile Devices](#).

Possible USB port installation locations

The number and installation locations of USB ports depend on the vehicle and vehicle equipment and are not available in all countries.

- In the center console.
- At the base of the interior rearview mirror.
- In the storage compartment in the center console.
- In the compartment underneath the center armrest.

 USB ports at the rear seats only come with a charging function.

Available Data Transfer Functions

The following USB data transfer functions are available depending on the vehicle equipment.

- App-Connect ⇒ [App-Connect](#).
- Media playback ⇒ [Media mode](#).
- Update, e.g. of the navigation data ⇒ [Navigation data](#).

Instructions and restrictions

- Only use suitable USB connection cables. The USB connection cable must match the USB port installed in the vehicle.
- Dirty, overheated or damaged data carriers are not to be used. Read and heed the information provided by the manufacturer.
- Difference in quality between data carriers from different manufacturers can cause problems with media playback.
- Using USB extension cables, USB adapters or USB hubs may result in malfunctions or failure of the USB functions.

Bluetooth® interface

 Please read the introductory information and heed the Warnings and Notice ⇒ [Introduction](#).

The Bluetooth interface is a wireless connection.

In Bluetooth audio mode, audio files that are on a Bluetooth audio source that is connected via Bluetooth, such as a cell phone, can be played through the vehicle speakers.

Bluetooth audio mode is only possible in vehicles equipped with a factory-installed mobile phone interface that supports this function.

Bluetooth profiles

The Infotainment system is equipped with a Bluetooth interface at the factory.

A maximum of three Bluetooth devices can be connected at the same time.

The following Bluetooth profiles may be available in the specified version or in another version:

- HFP 1.7.
 - Telephony and handsfree mode.
- A2DP 1.3.
 - Music playback.
- AVRCP 1.6.
 - Display and operation for music playback.
 - Transfer of cover art.
- PBAP 1.2.
 - Access to phone book and call lists.
- MAP 1.4.
 - Access to SMS and e-mail.
- SPP 1.2.
 - Serial data transfer via Bluetooth.

Starting Bluetooth audio

Requirements

- ✓ The Bluetooth audio source is paired with and connected to the Infotainment system ⇒ *Coupling, connecting and managing*.
- ✓ The Bluetooth audio source supports the Bluetooth profile Advanced Audio Distribution Profile (A2DP).

1. Lower the volume on the Infotainment system.
2. Activate Bluetooth visibility on the external Bluetooth audio source, such as a cell phone.
3. Open the Media menu.
4. Tap **Source** and select **Bluetooth audio**.
5. If necessary, start playback on the Bluetooth audio source manually.

When playback from the Bluetooth audio source is finished, the Infotainment system remains in Bluetooth audio mode.

Controlling playback

The extent that the Bluetooth audio source can be controlled by the Infotainment system depends on the type of Bluetooth audio source that is connected.

For media players that support the AVRCP Bluetooth profile, playback from the Bluetooth audio source can be started or stopped automatically when Bluetooth audio mode or another audio source is selected. Depending on the Bluetooth audio source, it may also be possible to display and play the track on the Infotainment system.

 **Because of the large number of possible Bluetooth audio sources, it is not possible to guarantee that all functions described can be performed correctly.**

 **On a connected Bluetooth audio source, all warning and operation tones, such as touch tones on a cell phone, should generally be switched off to avoid interference and malfunctions.**

 **Depending on the device, if an external media player is connected to the Infotainment system via Bluetooth and the USB port  at the same time, the Bluetooth audio connection may be automatically disconnected.**

Wi-Fi hotspot

Introduction

The "Wi-Fi hotspot" function is not available in all countries and vehicles.

Some Infotainment systems can be used as a Wi-Fi hotspot for Internet access on up to eight Wi-Fi devices.

Some Infotainment systems can use the Wi-Fi hotspot on an external Wi-Fi device (Wi-Fi client) ⇒ *Setting up a Wi-Fi client*.

A data connection is required for connecting to the Internet and for certain functions, such as using VW Car-Net.

 **The Wi-Fi connection is encrypted by default with WPA2 encryption for security reasons. Volkswagen recommends always using WPA2 encryption. Observe legal regulations for the country where you are operating the vehicle.**

 There may be fees for the required data connection. Volkswagen recommends using a mobile phone plan with a flat rate data package due to the possible volume of data. Information on this can be obtained from the mobile network provider.

 Depending on your mobile data rate, additional costs, such as roaming fees, may result from downloading and using data plans online, especially in other countries.

 When crossing the border into countries with different permitted radio frequencies than your own country, use of the wireless function/the Wi-Fi must be deactivated to comply with legal provisions. The wired functions are not affected by this restriction and can still be used.

Opening the Wi-Fi settings

1. Tap **HOME** ►  ► Wi-Fi.

2. Make corresponding entries or tap function keys.

Changes will be automatically applied when the menu is closed.

Setting options

- Setting up the Infotainment system as a Wi-Fi hotspot.
- Connecting to the Infotainment system via a quick connection.
- Connecting with the Wi-Fi.

Establishing a data connection

Wi-Fi

- Wi-Fi in accordance with IEEE 802.11 a/b/g/n/ac.
- 2.4 GHz and 5 GHz data transfer.
- Three Wi-Fi modes at once:
 - Tethering (2.4 GHz or 5 GHz).
 - 2.4 GHz access point.
 - 5 GHz access point.
- Wi-Fi antenna.
 - One multi-band aerial each for 2.4 GHz and 5 GHz.
- Up to eight Wi-Fi devices can be connected at the same time.
- Internet connection via Wi-Fi:
 - Tethering via cell phone or eSIM.
 - Wi-Fi hotspot for clients in the vehicle.
- Apple CarPlay™ via Wi-Fi.
- Android Auto™ via Wi-Fi.
- Simplified pairing process via Wi-Fi Protected Setup (WPS) or Quick Response Code (QR code).

Possible data connection types

External Wi-Fi device: Use the Wi-Fi hotspot of an external Wi-Fi device, e.g. a cell phone ⇒ [Setting up a Wi-Fi client](#).

eSIM (embedded SIM): The vehicle has a control module with an integrated eSIM card. In order to use the Wi-Fi hotspot, you need to purchase data plans via the Webshop of our external mobile communications partner.

The types of possible data connections depend on the country and equipment.

Requirements

✓ Network settings ► Allow Internet connection is activated in the settings menu.

Or: Data connection ► Integrated data connection is activated.

Setting up and deactivating a Wi-Fi hotspot

Depending on the vehicle equipment and the country, the Infotainment system can be used as a Wi-Fi hotspot for Internet access on up to eight Wi-Fi devices, e.g. cell phones.

To connect to the Internet, a data connection is also required, e.g. via an internal eSIM card or an external Wi-Fi device.

The possible types of data connections depend on the country and the Infotainment system being used.

Setting up a Wi-Fi hotspot

You will need to enter information both on the Wi-Fi device and in the Infotainment system.

1. Tap **HOME** ►  ► Wi-Fi ► Infotainment system as hotspot.

2. Tap Use as hotspot and activate it.
3. Search for the Wi-Fi hotspot's name on the Wi-Fi device.
4. Enter the network key that is displayed on the Wi-Fi device and confirm it.

The Wi-Fi connection will be established. If necessary, you may need to enter additional information on the Wi-Fi device.

5. *Optional:* repeat the process to connect other Wi-Fi devices.

 **The name and network key for the Wi-Fi hotspot are generated automatically. You can then change these and set your own name and network key for the Wi-Fi hotspot.**

Deactivating a Wi-Fi hotspot

1. Tap (HOME) ►  ► Wi-Fi ► Infotainment system as hotspot.
2. Tap Mobile hotspot and deactivate it.

Setting up a Wi-Fi client

The Infotainment system can use the Wi-Fi hotspot of an external Wi-Fi device, e.g. of a cell phone, to connect to the Internet and use mobile online services.

Connecting to Wi-Fi

1. Activate the Wi-Fi hotspot on the Wi-Fi device. Refer to the manufacturer's operating instructions.
2. Tap (HOME) ►  ► Wi-Fi ► Wi-Fi: .
3. Tap (Search for Wi-Fi).

The Infotainment system scans for Wi-Fi hotspots in the area. This scan process can take a few seconds.

4. Select the Wi-Fi network of the preferred Wi-Fi device.
5. Enter the Wi-Fi hotspot network key in the Infotainment system and confirm it.

The Wi-Fi connection will be established. If necessary, you may need to enter additional information on the Wi-Fi device.

 **Due to the large number of Wi-Fi devices that are available, there is no guarantee that all functions will always be available.**

 **The Wi-Fi function may not be available in all countries and may vary.**

WPS with Infotainment system as client

- ✓ The Wi-Fi device supports WPS.

1. Tap (HOME) ►  ► Wi-Fi ► Wi-Fi: .
2. Tap WPS quick connection (WPS button).
3. Activate WPS on the external Wi-Fi device.

The Wi-Fi connection will be established. If necessary, you may need to enter additional information on the Wi-Fi device.

 **WPS is not supported by all Wi-Fi devices. In this case, connect manually:**

- Setting up the Infotainment system as a Wi-Fi hotspot ⇒ *Wi-Fi hotspot*, ⇒ *Setting up and deactivating a Wi-Fi hotspot*.

Or: Connect the Infotainment system to the Wi-Fi hotspot of an external Wi-Fi device as a client .

Quick connection

Quick connection makes it possible to easily and quickly set up a wireless local network with encryption. In several countries, the function can alternatively be executed by scanning in a QR code.

WPS with the Infotainment system as a Wi-Fi hotspot

Requirements

- ✓ The Wi-Fi hotspot of the Infotainment system is activated.
- ✓ The Wi-Fi device supports WPS.

1. Tap (HOME) ►  ► Wi-Fi.
2. Tap Quick connection with Infotainment system.
3. Activate WPS on the external Wi-Fi device to be connected.

The Wi-Fi connection will be established. If necessary, you may need to enter additional information on the Wi-Fi device.

4. Repeat the process to connect additional Wi-Fi devices.

Only one WPS connection can be established at a time. If multiple connection attempts start at the same time, all connection attempts will fail.

Setting up a Wi-Fi connection via NFC

The Wi-Fi connection can be established via NFC using the shelf of the cordless charging function.

 **The availability of the Wi-Fi connection via NFC depends on the cell phone used, its operating system and the Infotainment system used.**

Requirements

- ✓ NFC technology and a rear shelf for the wireless charging function are installed in the vehicle.
- ✓ NFC is activated on the Wi-Fi device.
- ✓ The Wi-Fi hotspot of the Infotainment system is activated.

1. Tap   ► Wi-Fi.

2. Tap Quick connection with Infotainment system.

3. Unlock the Wi-Fi device and place on the rear shelf for the wireless charging function ⇒ [Charging Options for Mobile Devices](#).

The Wi-Fi device is connected as client to the Wi-Fi hotspot of the Infotainment system.

 **The wireless charging function is deactivated while the Infotainment system is in the Wi-Fi settings menu. Wireless charging is reactivated if you leave the settings menu.**

 **On older Wi-Fi devices, the functionality may be restricted or not work at all. Ensure that you always use the latest software version for your Wi-Fi device.**

Setting up a Wi-Fi connection via QR code

The Wi-Fi connection can also be established by scanning the corresponding QR code.

Requirements

- ✓ The Wi-Fi hotspot of the Infotainment system is activated.
- ✓ A suitable application for scanning QR codes is installed on the Wi-Fi device.

1. Tap   ► Wi-Fi.

2. Tap Quick connection with Infotainment system.

3. Scan the QR code on the screen of the Infotainment system with the Wi-Fi device.

The Wi-Fi device is connected as client to the Wi-Fi hotspot of the Infotainment system.

App-Connect

Introduction

App-Connect makes it possible to display and control content and functions displayed on the cell phone through the Infotainment system screen.

To do this, the cell phone must be connected to the Infotainment system via a USB interface with a data transfer function.

Some technologies can also be used with App-Connect Wireless via the Bluetooth interface.

The following technologies may be available:

- Apple CarPlay™.
- Apple CarPlay™ Wireless.
- Android Auto™.
- Android Auto™ Wireless.
- MirrorLink®.

Which App-Connect technologies are available to you depends on the country and on the cell phone in use.

MirrorLink, Apple CarPlay or Android Auto are technologies which are operated by third parties and provided by Volkswagen. Volkswagen is not responsible if these technologies are canceled, discontinued or deactivated during the service life of the vehicle.

You can find more information on the Volkswagen website.

App-Connect wireless function in the event of border crossings

In the event of border crossings into countries with different permissible radio frequencies than your own country, please note the following:

- The App-Connect wireless function may be limited due to legal provisions, or may not be possible at all. This can be indicated by a message in the Infotainment system.
- The App-Connect wireless function must be deactivated due to legal provisions. The Wi-Fi hotspot must be deactivated.

This does not apply to wired functions.

Opening the App-Connect main menu

Navigation to the App-Connect main menu depends on the Infotainment system being used.

1. Tap  .

Setting up App-Connect Wireless

In order to use App-Connect Wireless, first pair the cell phone with the Infotainment system.

Connecting a cell phone for the first time

1. Unlock the cell phone.
2. Activate Wi-Fi reception and Bluetooth on the cell phone.
3. Connect the cell phone to the Infotainment system via a USB cable or Bluetooth.
4. Open the App-Connect main menu if it does not open automatically.
5. Select the cell phone and your preferred technology.
6. Allow the Infotainment system the required access. To do this, confirm authorization requests on the cell phone.
7. Disconnect the USB connection and re-connect with the Infotainment system using Wi-Fi or Bluetooth.

App-Connect Wireless set-up is complete.

Pairing is complete. The paired cell phone can now use App-Connect Wireless in the future without a USB connection.

If any pop-up menus were dismissed during the connection process, App-Connect Wireless will not be available. In this case, Volkswagen recommends deleting the devices from the cell phone settings and Infotainment system and restarting the connection process.

 **App-Connect Wireless may not be supported by all technologies.**

WARNING

Using apps while driving can distract from traffic. Driver distraction can cause serious accidents and fatal injuries.

- Only use apps and functions when the vehicle is stationary.
- Always drive attentively and responsibly.

WARNING

If unsuitable apps are used or apps are not used correctly, this may result in vehicle damage and accidents with serious or even fatal injuries.

- Protect the cell phone and its apps from misuse.

 **Volkswagen is not responsible for vehicle damage that is caused by low-quality or malfunctioning third-party apps, inadequate programming of third-party apps, insufficient network strength, data loss, misuse of mobile devices, or malware on data carriers, computers, tablets and cell phones.**

Apps

 **Please read the introductory information and heed the Warnings and Notice** ⇒  **Introduction.**

Content from Volkswagen apps and third party provider apps displayed on cell phones can be displayed on the Infotainment system screen using Volkswagen App-Connect.

Apps from third-party providers may be incompatible.

The use of apps and the required mobile phone connection may be subject to additional charges.

Apps can be based on many different designs and can also differ depending on the vehicle and country. The content, scope, and providers of the apps may vary. Furthermore, some apps depend on the availability of services from third party providers.

It cannot be guaranteed that the apps that are offered will be able to run on all cell phones and with all operating systems.

The apps provided by Volkswagen can also be changed, canceled, deactivated, reactivated, and enhanced without notice.

To avoid driver distraction, only certified apps can be used while driving.

Symbols and settings for App-Connect

 **Please read the introductory information and heed the Warnings and Notice** ⇒  **Introduction.**

Symbols in the App-Connect menu

The symbols present depend on the type of Infotainment system and the vehicle model.

 **Show further information.**  **Open the App-Connect settings menu.**  **Select the Apple CarPlay technology.**  **Select the Android Auto technology.**  **Select the MirrorLink technology.**

Setting options in the App-Connect settings menu

The setting options depend on the integrated Infotainment system.

Mobile devices: Open the device manager.

Allow MirrorLink messages to display: Messages are displayed when using MirrorLink.

Apple CarPlay™

 Please read the introductory information and heed the Warnings and Notice ⇒  **Introduction.**

Requirements

The following requirements must be met in order to use Apple CarPlay:

- ✓ The iPhone must support Apple CarPlay.
- ✓ Voice control (Siri) must be activated on the iPhone.
- ✓ Apple CarPlay must be activated in the iPhone settings without restrictions.
- ✓ If Apple CarPlay Wireless cannot be used, the iPhone must be connected to the Infotainment system via a USB connection. Only USB ports with data transfer are suitable for use with Apple CarPlay.
- ✓ The USB cable being used must be an original cable from Apple.

Apple CarPlay Wireless: Bluetooth and Wi-Fi must also be activated on the iPhone.

 **These technologies may not be available in all countries.**



 **Information on technical requirements, compatible iPhones, certified apps and availability can be found at the Volkswagen and Apple CarPlay website or at an authorized Volkswagen dealer or authorized Volkswagen Service Facility.**

Connecting



When connecting an iPhone for the first time, follow the instructions on the Infotainment system screen and the iPhone display.

The requirements must be met in order to use Apple CarPlay.

Starting Apple CarPlay

1. Tap  to open the App-Connect main menu.
2. Tap  to start Apple CarPlay.

Disconnecting

1. To get to the App-Connect main menu, tap  in Apple CarPlay mode.
2. Tap  to end the active connection.

The presentation of the function keys in the display may vary.

Special conditions

During an active connection with Apple CarPlay, the following conditions apply:

- Bluetooth connections between the iPhone and the Infotainment system are not possible.
- If there is an active Bluetooth connection between the iPhone and the Infotainment system, it will be automatically disconnected.
- For an iPhone connected with the Infotainment system via Apple CarPlay, phone functions can only be accessed via Apple CarPlay.
- The connected iPhone cannot be used as a media device in the Media main menu.
- It is not possible to use the internal navigation and Apple CarPlay navigation at the same time. The route guidance which was started last ends the previous active one.

Voice control

1. Tap  briefly to start the Infotainment system voice control.

Or: to start voice control (Siri) on the connected iPhone, tap and hold .

Android Auto™

 Please read the introductory information and heed the Warnings and Notice ⇒  **Introduction.**

Requirements

- ✓ The cell phone – hereafter referred to as a smartphone – must support Android Auto.
- ✓ An Android Auto app must be installed on the smartphone.
- ✓ If Android Auto Wireless cannot be used, the smartphone must be connected to the Infotainment system with a USB connection that allows data transfer.
- ✓ The USB cable used must be an original cable from your mobile device manufacturer.

Android Auto Wireless: Bluetooth and Wi-Fi must also be activated on the smartphone.

 **These technologies may not be available in all countries.**

 **Information on technical requirements, compatible smartphones, certified apps and availability can be found on the Volkswagen and Android Auto websites or at an authorized Volkswagen dealer or authorized Volkswagen Service Facility.**

Connecting

When connecting a smartphone for the first time, follow the instructions on the Infotainment system screen and the smartphone display.

The requirements must be met in order to use Android Auto.

1. Tap to open the App-Connect main menu.
2. Tap to establish the connection with the smartphone.

Disconnecting

1. Tap in Android Auto mode to open the App-Connect main menu.
2. Tap to end the active connection.

Special conditions

During an active connection with Android Auto, the following conditions apply:

- An active Android Auto device can also be connected with the Infotainment system via Bluetooth (hands-free profile, HFP) at the same time.
- Phone functions are possible through Android Auto. The Infotainment system phone function can also be used if the Android Auto device is connected to the Infotainment system via Bluetooth at the same time.
- An active Android Auto device cannot be used as a media device in the Media main menu.
- It is not possible to use the internal navigation and Android Auto navigation at the same time. The route guidance which was started last ends the previous active one.
- The instrument cluster display will not display information about media mode.

Voice control

1. Tap briefly to start the Infotainment system voice control.
Or: Tap and hold the button to start voice control of the connected smartphone.

MirrorLink®

Please read the introductory information and heed the Warnings and Notice ⇒ [Introduction](#).

Function keys

Returns to the App-Connect main menu. Here you can end the MirrorLink connection, connect another cell phone, or select another technology. Tap to display the cell phone on the Infotainment system screen. Tap to open the list of apps supported by MirrorLink. Tap to close apps that are open. Then tap the apps to be closed or tap the **Close all** function to close all open apps.

Requirements

- ✓ The cell phone must support MirrorLink.
- ✓ The cell phone must be connected to the Infotainment system via a USB connection with data transfer.
- ✓ The USB cable used must be an original cable from your cell phone manufacturer.
- ✓ Depending on the cell phone in use, an appropriate Car Mode app must be installed on the device to use MirrorLink.

Information about technical requirements, compatible cell phones, certified apps and availability can be found via the Volkswagen and MirrorLink website or at your authorized Volkswagen dealer or authorized Volkswagen Service Facility.

Connecting

When connecting a cell phone for the first time, follow the instructions on the Infotainment system screen and the cell phone display.

The requirements must be met in order to use MirrorLink.

1. Tap App-Connect to open the App-Connect main menu.
2. Tap to connect to your cell phone.

Disconnecting

1. To get to the MirrorLink main menu, tap .
2. Tap to end the active connection.

Special conditions

When there is an active connection with MirrorLink, the following conditions apply:

- An active MirrorLink device can also be connected with the Infotainment system at the same time via Bluetooth.
- If the MirrorLink device is connected to the Infotainment system via Bluetooth, you can use the Infotainment system phone function.
- An active MirrorLink device cannot be used as a media device in the Media main menu.
- You can view information about telephone operation in the instrument cluster display.
- The instrument cluster display will not show upcoming turns or display information about media mode.

Mobile online services

myVW with Connected Features by Car-Net®

Introduction

VW Car-Net Ready

Your vehicle is equipped with VW Car-Net hardware, including a three-button module in the roof console. In order to use the VW Car-Net services, you need a subscription to them and to activate them. Many of the services come at an additional cost. Some services may be offered as a trial subscription for a limited period of time.

VW Car-Net requires a mobile network connection and GPS signal availability.

WARNING

Using apps while driving can distract from traffic. Driver distraction can cause serious accidents and fatal injuries.

- Only use apps and functions when the vehicle is stationary.
- Always drive attentively and responsibly.

 Once you have registered with VW Car-Net, positional information from the vehicle is transmitted every time one of the VW Car-Net buttons is tapped. This also occurs in the event of an automatic emergency call or periodically in conjunction with using the VW Car-Net functions. Volkswagen has the capability to determine the exact position of the vehicle at any time, should this be required legally, by order or compulsory measure, or be necessary in emergencies, provided that the VW Car-Net equipment has not been deactivated. For further information, please contact the VW Car-Net Response Center on 1-833-648-2735. Calls may be monitored or recorded.

 Volkswagen collects, processes, shares and transmits information about you and your vehicle in compliance with the VW Car-Net terms and conditions and privacy provisions. For more information, please visit our website at:

<https://carnet.vw.com/#/home>

Situations that can affect system functions

 Please read the introductory information and heed the Warnings and Notice ⇒  Introduction.

Even if requirements for the usage of these services have been met, the performance of VW Car-Net may be impaired or blocked by various factors that are outside of the control of Volkswagen. In particular, this includes:

- Maintenance, repairs, deactivations, software updates, and technical improvements to the telecommunications systems, satellites, servers, and databases.
- Switching the mobile network standard to transmit mobile data through the telecommunications provider, for example, from UMTS to EDGE or GPRS.
- Switching off an existing mobile network standard via the telecommunications provider.
- Malfunction, impairment, or interruption of the mobile network and GPS reception, for example due to high speeds, solar storms, weather conditions, regional circumstances, malfunctioning equipment, and high mobile network usage in the applicable radio cells.
- If you are in a location with no or very poor cell phone or GPS reception. These locations may include tunnels, areas between tall buildings, garages, parking ramps, underpasses, mountains, and valleys.
- Limited availability of information or incomplete or incorrect information from third-party providers, such as on map displays.
- In countries, federal states and regions where VW Car-Net not offered.

VW Car-Net® Portfolio

 Please read the introductory information and heed the Warnings and Notice ⇒  Introduction.

VW Car-Net is part of Connected Vehicle Services and makes driving a Volkswagen more convenient. The In-Vehicle Services can be used via the control for voice services in the roof console.

Emergency Call Service

If you or your passengers require medical assistance or help from the police, press the emergency call button. You will be connected to a contact partner at the Volkswagen emergency call center, who will assess your situation and, if required, will send the police or medical help to the GPS location of your vehicle.

 Only press the emergency call button if you require medical assistance or help from the police via VW Car-Net.

 Volkswagen is not responsible for the reaction time of police or medical emergency services, or the assistance they provide on site.

Roadside assistance call

In the event of a breakdown, press the roadside assistance call button. You will be connected to a contact partner at VW Roadside Call Assist, who will send help to your GPS location.

 Do not use the roadside assistance call button or the information call button to request police or medical help.

Information call

Press the information call button. You will be connected to a contact partner at the VW Car-Net call center, who can help you in the following cases, amongst others:

- Logging in and registering services.
- Finding and sending routes to the navigation system.
- Locating VW service partners.

Registration required

If you want to use VW Car-Net, you must log in and activate the functions. Many functions require a paid subscription. Some functions can be provided with a time-limited trial subscription. For more information on VW Car-Net functions, visit our website at:

<https://carnet.vw.com/#/home>

After registering successfully, inform all users of the vehicle that the following data from the vehicle is sent or automatically received:

- Speed
- Location.
- Further information.

Functions and services of VW Car-Net and every trial or paid subscription may be adjusted, ended, deactivated, reactivated or enhanced without additional notifications. You can read details regarding subscription, Terms of Use and privacy policy at:

<https://carnet.vw.com/#/home>

If you have any questions or would like to start a subscription, contact our VW Car-Net Response Center on 1-833-648-2735, or visit our website at:

<https://carnet.vw.com/#/home>

Infotainment system

First steps

Introduction

The functions and settings of the Infotainment system depend on the vehicle equipment and are not available in all countries.

Prior to the first use

Before using the Infotainment system for the first time, read the following points to be able to fully use the available functions and settings:

- Observe the safety instructions ⇒ [Safety instructions](#).
- Reset the Infotainment system to factory settings ⇒ [System and sound settings](#).
- Find your favorite radio stations, also referred to in the following as stations, and save them on the station preset buttons to quickly access them ⇒ [Radio mode](#).
- Only use suitable audio sources and data carriers ⇒ [Media mode](#).
- Use current map data for the navigation system.
- Pair a cell phone in order to use the phone interface to make calls ⇒ [Mobile phone interface](#).
- Register on VW Car-Net® to use related services.

Other applicable documents

In addition to this manual, please refer to the following documentation when using this Infotainment system and its components:

- Supplements to your Owner's Manual.
- Operating instructions for the cell phone or audio sources.
- Operating instructions for external data carriers and players.
- Instructions for retrofitted or additional Infotainment accessories.

Safety instructions

 Refer to ⇒  and .

- Some functions may contain links to websites that are administered by third parties. Volkswagen does not assume ownership of third-party sites reached through links and is not responsible for their content.
- Some functions may contain third-party information that originates from third-party providers. Volkswagen is not responsible for the accuracy, currentness, and completeness of this non-proprietary information, and for ensuring that the rights of third parties are not violated.
- The radio stations and owners of the data carriers and audio sources are responsible for the transmitted content.
- Parking buildings, garages, underpasses, tunnels, tall buildings, mountains and valleys or electrical devices such as battery chargers can also interfere with cell phone, GPS and radio signal reception.
- Foil stickers or stickers with a metal layer placed on the antenna and on the windows can impair radio reception.
- Read and follow the applicable manufacturer's operating instructions when using cell phones, data carriers, external devices, and external audio and media sources.

WARNING

The Infotainment system's central processor is networked with the control modules installed in the vehicle. If the central processor is incorrectly repaired, removed or reinstalled, there is an increased risk of accident and injury due to the control module functioning incorrectly or not functioning at all.

- Never replace the central processor with a used central processor from a scrap vehicle or from recycling.
- Always have the central processor repaired, removed and reinstalled by suitably qualified professionals. Volkswagen recommends contacting an authorized Volkswagen dealer or authorized Volkswagen Service Facility.

WARNING

Reading information on the screen, operating the Infotainment system and connecting, inserting or removing a data carrier or audio source while driving can distract from traffic. Driver distraction can cause accidents and injuries.

- Always drive attentively and responsibly.

WARNING

Displays and information on the screen may be difficult to read if the lighting conditions are unfavorable or if the screen is damaged or dirty.

- Never allow displays and information on the screen to cause you to engage in behavior that poses a safety risk. Always drive attentively and responsibly.

WARNING

Setting the volume too high prevents you from hearing audible signals. Failure to hear audible signals from outside the vehicle can lead to accidents.

- Adjust the volume settings in the Infotainment system so that audible signals from outside the vehicle (such as sirens on emergency service vehicles) can still be heard.

WARNING

Setting the volume too high can cause hearing damage even if you are exposed to a loud volume for only a short time.

- Select a volume that is at a comfortable level for all vehicle occupants.
- Avoid excessive volume levels.

WARNING

Sudden volume fluctuations can distract the driver, e.g. when an audio or media source is connected or changed. This could cause accidents and injuries.

- Reduce the volume level before changing or connecting an audio or media source, for example.

WARNING

The following conditions may prevent or cause interruptions to emergency calls, phone calls, and data transmission:

- If you are in a location with no or very poor cell phone or GPS reception.
- If you are in a location where there is good cell phone and GPS reception, but the telecommunications provider's mobile communications network is malfunctioning or unavailable.
- If the vehicle components required for emergency calls, phone calls, and data transmission are damaged, not operating, or have insufficient power.
- If the cell phone battery is drained or if the battery charge level is too low.

WARNING

Radio stations can broadcast messages about disasters and dangers. It may not be possible to receive or send messages under the following conditions:

- If you are in a location with no radio reception, or insufficient reception.
- If the radio station's frequency bands are malfunctioning or not available.
- If the speakers and vehicle components required for radio reception are damaged, not operating, or have insufficient power.

WARNING

In some countries and mobile networks, emergency calls can only be made under the following conditions:

- A cell phone with an unlocked SIM card and sufficient calling credit is connected to the vehicle's phone interface.
- Adequate network coverage is available.

WARNING

If a cell phone or CB radio is used inside the vehicle without connection to an outside antenna, the limit values for electromagnetic radiation inside the vehicle may be exceeded and endanger the health of all vehicle occupants.

- Keep the cell phone antenna at least 20 cm (approximately 8 inches) away from any active medical implants, such as pacemakers, because cell phones can impair the function of active medical implants.
- Do not carry a cell phone that is turned on directly above or in the immediate vicinity of any active medical implants, for example by keeping a phone in a shirt pocket.
- Immediately switch off cell phones if you suspect they could impair an active medical implant, e.g. pacemaker, or other medical device.

WARNING

Loose, unsecured or incorrectly mounted cell phones, external devices and accessories can be thrown through the vehicle interior in the event of sudden driving or braking maneuvers or a collision. This can cause accidents and serious injuries.

- Secure cell phones, external devices and accessories outside of the airbag deployment zone or stow them securely.
- Always secure or store cell phones, external devices, audio sources and accessories in the dedicated compartments and holders in the vehicle so that they cannot be thrown through the vehicle interior and cannot impede the driver.
- Never leave heavy, hard or sharp objects in the pockets of clothing.
- Arrange cables for external devices and audio sources so that they are not in the way of the driver.

WARNING

Driving recommendations and traffic signs displayed in the navigation system may differ from the actual traffic situation and you must not be tempted to take safety risks.

- Always drive attentively and be ready to intervene at any moment.
- Always bear in mind that traffic signs, signal systems, traffic regulations and local circumstances have priority over the driving recommendations and displays in the navigation system.
- Always adapt your speed and driving style to the current visibility, weather, road and traffic conditions.

NOTICE

Radiation from cell phones that are switched on can interfere with sensitive technical and medical devices, potentially causing malfunctions or damage to the devices.

- Always switch off the cell phone in areas with special regulations relating to or prohibiting the use of cell phones.

NOTICE

Setting the volume too high and excessively loud or distorted playback can damage the speakers.

- Select the volume setting so that the speakers are not damaged.

User information

 Refer to  and  *Safety instructions*.

- The Infotainment system requires a few seconds to perform a complete system start, and will not respond to inputs during that time. During the system start, only the Rear Assist camera can be displayed.
- The Infotainment system must start completely before all displays can appear and functions can be performed. The length of time that it takes for the system to start depends on the scope of functions in the Infotainment system, and it can take longer to start at low and high temperatures.
- Observe local regulations and legal requirements when using the Infotainment system and corresponding accessories, such as a headset or headphones.
- For the Infotainment system to function, it must be switched on and the vehicle must be set to the current date and time if necessary.
- A missing function key in the screen is not the result of a device error, but instead corresponds to the country-dependent equipment.
- Some Infotainment system functions can only be selected when the vehicle is stationary. In some countries, it is also necessary to turn the driving mode selector to neutral position **N** or press the  electronic parking brake button on the driving mode selector. This is not a malfunction, but rather compliance with legal regulations.
- Some countries may have restrictions regarding the use of Bluetooth® devices. Information can be obtained from the local authorities.
- If the 12 V vehicle battery has been disconnected, switch on the ignition before switching on the Infotainment system.
- Displays on the screen may vary due to differences in the settings, and the Infotainment system may function differently than described in this manual.
- The Infotainment system will switch off automatically once the vehicle is no longer drive-ready and if the 12 V vehicle battery charge level is too low.
- In some vehicles with a parking system, the volume of the current audio source may be automatically lowered when you shift into reverse. The volume reduction level can be adjusted.
- The Infotainment system contains information about the software contained in the system and the licensing terms under: Setup ► Copyright.
- If selling or loaning your vehicle, make sure that all data, files and settings stored are deleted, and that any external audio sources and data carriers are removed, if applicable.
- Certain functions in the Infotainment system require an active VW Car-Net account for the vehicle and an online connection to the Internet. In order to enable functions to be carried out, data transfer must not be restricted.

Overview and controls of the 12" version

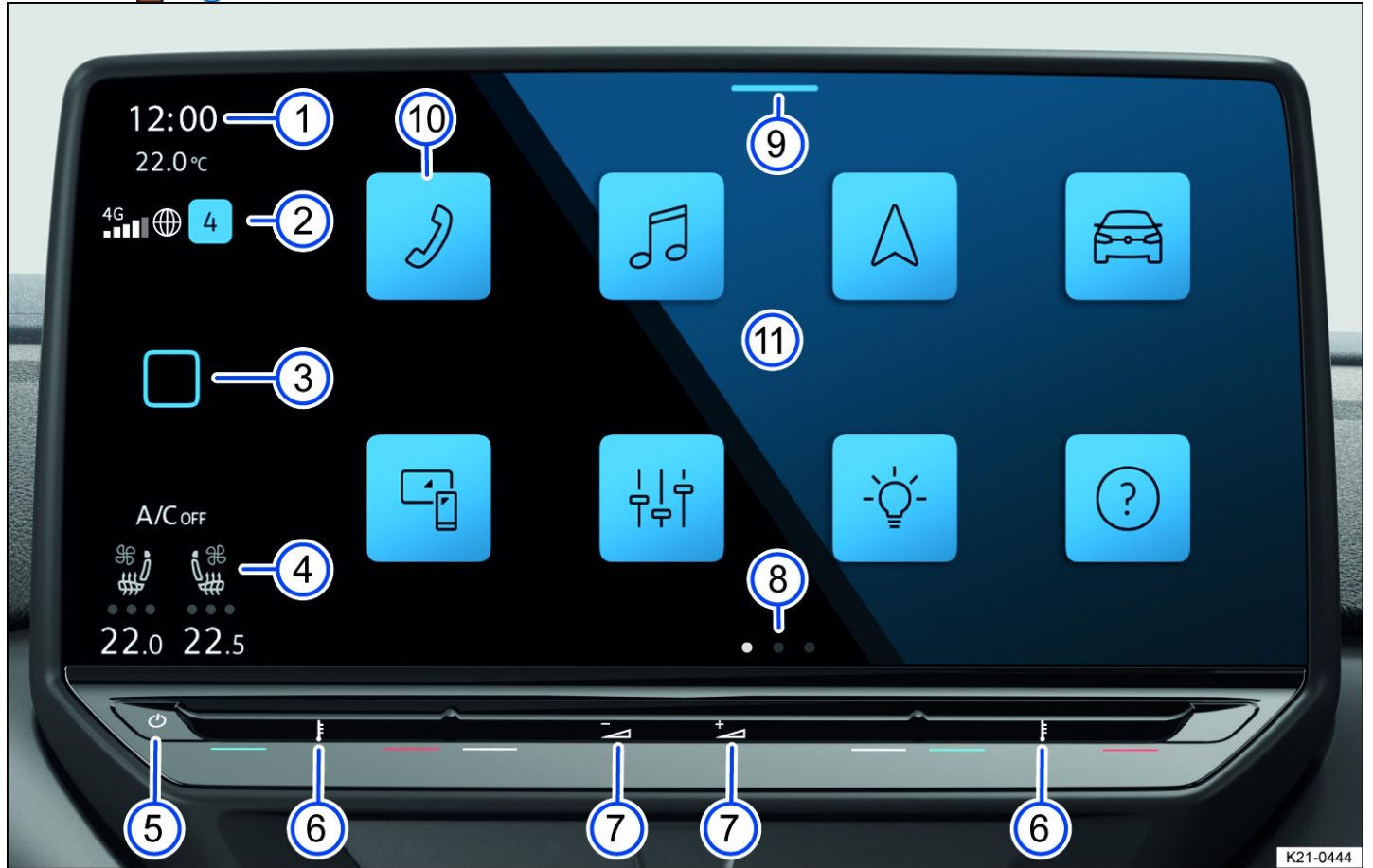

Fig. 113 Overview: display and control unit, 12" version.

- ① Time.
- ② Status display for the "Privacy settings" function with the eSIM signal strength display (availability depends on the country) and number of notifications.
- ③ Home Button: (hereafter: **HOME**).
- ④ Temperature display (can be adjusted) and status display for seat heating and seat ventilation (available depending on vehicle equipment).
- ⑤ Sensor area (Infotainment system on or off).
- ⑥ Touch control for temperature.
- ⑦ Touch control for volume.
- ⑧ Views (current view is highlighted).
- ⑨ Control Center.
- ⑩ Function keys for main menus.
- ⑪ Screen (touchscreen).

Further information and tips for operating the Infotainment system can be found in this Owner's Manual **Operating the Infotainment system.**

③ **Home Button:** (hereafter: **HOME**)

In some countries, the Home Button can be adjusted **System and sound settings**. The Home Button is hereafter referred to as **HOME**.

1. To open the home screen, tap **HOME**.

⑤ **Sensor area (Infotainment system on or off)**

1. Tap the sensor area to manually switch the Infotainment system on or off.

⑥ **Touch control for temperature**

Touch control for the driver seat and touch control for the front passenger seat.

- Swipe left to reduce the temperature.
- Swipe right to increase the temperature.

⑦ **Touch control for volume**

- Swipe left to reduce the volume.
- Swipe right to increase the volume.

8 Views (current view is highlighted)

Certain menus and functions have multiple views with different content. The current view is highlighted.

- Tap a selection to switch to a view.
- Swipe left or right on the screen to switch between views.

9 Control Center

The Control Center contains additional function keys for functions and notifications, e.g. the Auto Hold function can be switched on and off here. Displayed function can be configured ⇒ *Personalizing the Infotainment system*.

1. Tap the selection and swipe down to open the control center.

10 Function keys for main menus

You can configure the position of the function keys ⇒ *Personalizing the Infotainment system*.

1. To open a main menu, tap the corresponding function key e.g.  for navigation.

11 Screen (touchscreen)

You can operate the Infotainment system functions via the screen. The screen brightness can be adjusted from the Control Center. You will find detailed explanations of the different finger movements in the digital manual for the Infotainment system, if available ⇒ *Operating the Infotainment system*.

1. Tap **(HOME)**   Operation.

Gesture control (without position numbers)

Gesture control can also be switched on. If gesture control is switched on, this is shown on the screen.



1. Tap **(HOME)**  Screen .

Overview and controls of the 10" version

Refer to  and  *Safety instructions*.



Fig. 114 Overview: display and control unit, 10" version.

- 1 Time.
- 2 Status display for the "Privacy settings" function with the eSIM signal strength display (availability depends on the country) and number of notifications.
- 3 Home Button:  (hereafter: **(HOME)**).
- 4 Temperature display (can be adjusted ) and status display for seat heating and seat ventilation (available depending on vehicle equipment).
- 5 Sensor area (Infotainment system on or off).
- 6 Touch control for temperature.

- 7 Touch control for volume.
- 8 Views (current view is highlighted).
- 9 Control Center.
- 10 Function keys for main menus.
- 11 Screen (touchscreen).

 Further information and tips for operating the Infotainment system can be found in this Owner's Manual ⇒ [Operating the Infotainment system](#).

3 Home Button: (hereafter: **HOME**)

In some countries, the Home Button can be adjusted ⇒ [System and sound settings](#). The Home Button is hereafter referred to as **HOME**.

1. To open the home screen, tap **HOME**.

5 Sensor area (Infotainment system on or off)

1. Tap the sensor area to manually switch the Infotainment system on or off.

6 Touch control for temperature

Touch control for the driver seat and touch control for the front passenger seat.

- Swipe left to reduce the temperature.
- Swipe right to increase the temperature.

7 Touch control for volume

- Swipe left to reduce the volume.
- Swipe right to increase the volume.

8 Views (current view is highlighted)

Certain menus and functions have multiple views with different content. The current view is highlighted.

- Tap a selection to switch to a view.
- Swipe left or right on the screen to switch between views.

9 Control Center

The Control Center contains additional function keys for functions and notifications, e.g. the Auto Hold function can be switched on and off here. Displayed function can be configured ⇒ [Personalizing the Infotainment system](#).

1. Tap the selection and swipe down to open the control center.

10 Function keys for main menus

You can configure the position of the function keys ⇒ [Personalizing the Infotainment system](#).

1. To open a main menu, tap the corresponding function key e.g.  for navigation.

11 Screen (touchscreen)

You can operate the Infotainment system functions via the screen. The screen brightness can be adjusted from the Control Center. You will find detailed explanations of the different finger movements in the digital manual for the Infotainment system, if available ⇒ [Operating the Infotainment system](#).

1. Tap **HOME** ►  ►  ► Operation.

Gesture control (without position numbers)

Gesture control can also be switched on. If gesture control is switched on, this is shown on the screen.

1. Tap **HOME** ►  ► Screen ► Hand gesture.

Operating the Infotainment system

 Refer to ⇒  and  [Safety instructions](#).

Opening the digital manual of the Infotainment system (if available)

Further information and tips on operation can be found in the digital manual for the Infotainment system.

1. Tap **HOME** ►  ► .

Switching the Infotainment system on and off

When the driver gets in the vehicle, the Infotainment system automatically switches on. When the driver gets out of the vehicle, the Infotainment system automatically switches off.

The Infotainment system starts up when the ignition is switched on, unless it was previously switched off manually.

If the Infotainment system freezes, the Infotainment system automatically restarts. If restarting does not work, tap and hold the sensor area for approximately 15

seconds to switch the Infotainment system on and off.

The Infotainment system starts at the volume that was last set, as long as this does not exceed the preset maximum switch-on volume.

 **If you leave the vehicle while the ignition is not active, the Infotainment system switches off automatically.**















 **If you switch on the Infotainment system manually while the ignition is not active, it will switch off automatically after approximately 30 minutes without user input.**

Opening the home screen

1. Tap **HOME** ⇒ *Overview and controls of the 12" version*, ⇒ *Overview and controls of the 10" version*.

Main menus on the home screen

The following main menus may be shown as function keys on the home screen:

 **Ambient lighting, ambient light** ⇒ *Interior/reading lights, ambient lighting*.  **App-Connect** ⇒ *App-Connect*.  **Assistance systems** ⇒ *Driver assistance systems*.  **Vehicle** ⇒ *Driver information*.  **Help:** Here, you can find additional information about Infotainment system functions and operation, e.g. the quick guide.  **ID. software:** You will find information about the software version here.  **Sound** ⇒ *System and sound settings*.  **Charging** ⇒ *High-voltage battery*.  **Navigation** ⇒ *Navigation*.  **Radio/Media** ⇒ *Radio mode, ⇒ Media mode*.  **Legal**.  **Setup** ⇒ *System and sound settings*.  **Shop**.  **Stationary air conditioning** ⇒ *Heating and air conditioning system*.  **Telephone** ⇒ *Mobile phone interface*.

Configuring the home screen

In the display and control unit, you can configure the arrangement of the function keys, views and displays on the home screen or have them positioned by means of factory-supplied layout templates.

1. Tap the function key and hold until the function key is highlighted.
2. Move the function key to the preferred position and release it.

Scrolling through lists, switching titles

Select your desired function, setting or track via the touchscreen or the control knob.

Moving objects, adjusting volume

To adjust settings, e.g. those using sliders, or move areas of a menu around, move the objects around on the screen.

Personalize function keys and views depending on the vehicle equipment ⇒ *Personalizing the Infotainment system*.

Zooming in or out of pictures and maps shown on the screen

Recommendation: Use thumb and index finger.

1. Tap and hold the screen with two fingers at the same time.
 - To zoom in on the pictures and maps shown, slowly move your fingers apart.
 - To zoom out of the pictures and maps shown, slowly move your fingers together.

Brief interruptions to operation

Frequent operation of the Infotainment system within a short time period during the journey may lead to brief interruptions to operation. The interruption is automatically rectified after a short delay.

Personalizing the Infotainment system





 **Refer to** ⇒  and  **Safety instructions**.

Depending on the vehicle equipment, you can personalize the Infotainment system to access your favorite and frequently used functions quicker.

The Infotainment system views contain tiles for accessing additional menus and functions.

Configuring tiles



Configure the tiles by removing or adding views.

1. Tap and hold tiles until an additional window appears.
2. To open the configuration screen, tap .
 - To add a new view with tiles, tap  and tap on the desired template. New tiles are created without any functions.
 - Tap  to remove a view with tiles.
3. Tap  to close the configuration screen.
4. To return to View, tap  or tap any free area of the screen.

 **There are always at least two views available. They cannot be removed. Depending on the vehicle equipment, you can add two further views. A maximum of four views can be displayed.**

Adjusting tiles

Adjust the tiles and displayed tile functions in the Infotainment system views to manage the Infotainment system as you wish.

1. Tap and hold tiles until an additional window appears.
2. To add functions to a tile, tap on the desired tile.
3. Tap the desired function in the additional window. Various functions are available depending on the size of the tile.
4. To remove a function from a tile, tap on the desired tile and tap .
5. To return to View, tap  or tap any free area of the screen.

 For some tiles, more functions are available than can be seen initially in the additional window. Swipe to the left or right in the additional window to see all the functions.

Adjusting the control center

Personalize the Infotainment system's Control Center to access your favorite and frequently used functions quicker, such as the Auto Hold function.

1. Tap and hold the function until an additional window appears.
2. Tap the desired function in the additional window and hold until the function is highlighted.
3. Move the function to the preferred position and release it.

The active function is automatically removed from the control center and added to the additional window.

 For the control center, more functions are available than can be seen initially in the additional window. Swipe to the left or right in the additional window to see all the functions.

Opening personalization tips (if available)

Further information and tips on personalization can be found in the digital manual for the Infotainment system.

1. Tap    Adjustment.







System and sound settings

 Refer to   and  Safety instructions.

Changing settings

The meanings of the following symbols apply to all system and sound settings.

Changes will be automatically applied when the menu is closed.

or The setting is selected and activated or switched on. or The setting is not selected and deactivated or switched off.  or  Open the drop-down list.  Increase the set value.  Reduce the set value.  Go back stepwise.  Go forward stepwise.  Use the slide control to continuously change the set value.

System settings

The Over-the-Air Update can mean that some of the system settings listed here may no longer be available or new ones may be added.

The system settings may include the following functions, information, and setting options:

- Offline mode.
- Screen.
- Time and date.
- Language.
- Additional keyboard languages.
- Units.
- Voice control.
- Wi-Fi.
- Data connection.
- Mobile devices.
- Connect up VW Car-Net.
- Restore factory settings.
- System information.
- Copyright.
- Configuration assistant.

Opening system settings

1. Tap  Setup.

Sound settings

The sound settings may include information and setting options for equalizer, position, volume and setup.

Opening sound settings

1. Tap **(HOME)** ► Sound.

Adjusting the volume of external audio sources

Lower the volume of the Infotainment system before turning up the volume of an external audio source.

If the connected audio source plays too quietly, increase the output volume of the external audio source. If that does not correct the problem, set the input volume to Medium or Maximum.

If the connected external audio source plays too loudly or the sound is distorted, lower the output volume of the external audio source. If that does not correct the problem, set the input volume to Medium or Quiet.

Cleaning the screen

Refer to  and  *Safety instructions*.

When cleaning the screen, please note this checklist:

- ✓ The Infotainment system is switched off.
- ✓ Use a soft, clean cloth that has been moistened with water.
Or: use a cleaning cloth which is available from an authorized Volkswagen dealer or authorized Volkswagen Service Facility.
- ✓ For stubborn dirt:

NOTICE

If the screen is cleaned with incorrect cleaning agents or when dry, it may be damaged.

- Only apply gentle pressure.
- Do not use any aggressive cleaners or products which contain solvents. These types of cleaners can damage the device and cause glare on the screen.

NOTICE

If the cloth used to clean the screen is too moist, the screen can no longer be operated or switched off.

- Dry the screen and then leave the vehicle locked from the outside for at least two minutes.

Brands, licenses, copyright

Refer to  and  *Safety instructions*.

Brands and licenses

Certain terms in this manual have the ® or ™ symbols. These symbols indicate emblems or registered trademarks. However, the absence of this symbol does not constitute a waiver of any rights associated with intellectual property.

Other product names are registered trademarks for the respective rights holder.

- Manufactured under license from Dolby Laboratories. Dolby and the double-D symbol are trademarks of Dolby Laboratories.
- Manufactured under license from Dolby Laboratories. Dolby, Pro Logic and the double-D symbol are trademarks of Dolby Laboratories.
- All SiriusXM services require a subscription. See the SiriusXM Customer Agreement for complete terms at www.siriusxm.com (US) or www.siriusxm.ca (Canada). All fees, content and features are subject to change. Satellite and steaming lineups may vary. SiriusXM, Pandora and all related logos are trademarks of Sirius XM Radio Inc. and its respective subsidiaries. All rights reserved.
- HD Radio Technology manufactured under license from iBiquity Digital Corporation. U.S. and Foreign Patents. For patents see <http://dts.com/patents>. HD Radio, Artist Experience, and the HD, HD Radio, and "ARC" logos are registered trademarks or trademarks of iBiquity Digital Corporation in the United States and/or other countries.
- Apple Music is a trademark of Apple Inc.
- SPOTIFY and the Spotify logo are among the registered trademarks of Spotify AB. Compatible vehicle and Spotify Premium subscription required, where available.
- Android Auto™ is a certified trademark of Google, Inc.
- Apple CarPlay™ is a certified trademark of Apple, Inc.
- Bluetooth® is a registered trademark of Bluetooth® SIG, Inc.
- iPod®, iPad®, and iPhone® are registered trademarks of Apple Inc.

- MirrorLink® and the MirrorLink® logo are certified trademarks of the Car Connectivity Consortium LLC.
- MPEG-4 HE-AAC audio coding technology and patents licensed from Fraunhofer IIS.
- SD® and SDHC® are trademarks or registered trademarks of SD-3C LLC in the USA and other countries.
- Windows® is a registered trademark of Microsoft Corporation, Redmond, USA.
- This product is protected by the intellectual property rights of Microsoft Corporation. Use or distribution of such technology outside of this product is prohibited without a license from Microsoft or an authorized Microsoft subsidiary.

Copyright

Audio and video files saved on data carriers and audio sources are generally subject to copyright regulations in compliance with applicable international and national laws. Observe legal regulations.

Radio mode

Introduction

In radio mode you can receive various available radio stations on different frequencies and save your favorites to the station buttons for quick access.

Available reception modes and bands depend on the vehicle equipment and are not available in all countries. Frequency bands in individual countries may be discontinued, switched off or no longer offered.

 **The radio stations are responsible for transmitted content.**

 **Other electrical devices connected in the vehicle can impair radio signal reception and cause noise in the speakers.**

 **Decals or metal-coated stickers on the vehicle windows can impair radio reception in vehicles with window antennas.**

Functions and radio symbols

 Refer to  and  **Safety instructions.**





Radio

The available scope of functions and also possible reception modes and bands depend on the vehicle equipment and are not available in all countries.

- FM dual tuner (diversity aerial).
- Summarized station list.
 - Merging of FM and DAB stations in a single list.
- Summarized memory list.
 - Merging of all stations stored on station preset buttons in a list.
 - Up to 36 station preset buttons as storage locations for favorites.
- Station logos.
- Antenna amplifier
- Internet radio.
- HD Radio™.
- Satellite radio:
 - SiriusXM™ 360L.

General symbols for radio operation



1. To open the main menu, open the home screen and tap  ⇒ *Overview and controls of the 12" version*, ⇒ *Overview and controls of the 10" version*.

 **FM**Select a FM reception mode.  **Internet Radio**Select the Internet Radio reception mode.  **SX**Select the satellite radio reception mode.  Select the band or reception mode.  Display favorites that are saved on station preset buttons.









Displayed small in a station list: Stations already saved on a station preset button as favorites.

 **Open current playback.**  **Opening the settings.**  Select the previous station from the station list or station on the previous station preset button.  Select the next station from the station list or station on the next station preset button.  Mute the radio.  Display the frequency band for manual selection of the FM frequency.

Only possible when the summarized station list is switched off in the settings in radio mode.

 Switch between radio and media mode.  My playlist.  Add stations as favorites.

Symbols for Internet Radio operation

 Open full-text search.  Unable to receive Internet radio.  Display the last internet radio station.  Display the 100 most popular internet radio stations.  Display the available Internet Radio podcasts.  Display Internet Radio stations that originate from the preferred country.  Display Internet Radio stations that transmit their program in the preferred language.  Display Internet Radio stations whose programs are of the preferred genre.  Display the

station selection. Display podcast episodes. Display associated stations and podcasts. Skip 15 seconds of podcast episode. Jump back 15 seconds of podcast episode.

Symbols for HD Radio operation

Station supports HD Radio. Radio Tune the HD Radio substations. Open the Emergency list of the “HD Radio Emergency Alerts” function.
 Radio HD Radio logo.

Symbols for satellite radio operation

Display the channel list. Open the window for entering the channel number. Set up listener profile.

Adjusting, tuning, and storing stations

Refer to and *Safety instructions*.

Selecting the frequency band or reception mode

Before selecting a station, you must first select a frequency band or reception mode. Various stations are available, depending on the selected frequency band or reception mode. The available bands and reception modes depend on the vehicle equipment and are not available in all countries.

1. Tap to open the list of bands and reception modes.
2. Select the band or reception mode, e.g. FM.

Searching for and selecting a station

There are different ways to search for and select stations. The options vary based on the frequency band and reception mode.

Selecting via the multi-function steering wheel

You can select stations either from the station list or Favorites via the multi-function steering wheel.

- To select the previous station, press on the multi-function steering wheel.
- To select the next station, press on the multi-function steering wheel.

Select via the frequency band (FM)

You can select frequencies and save them as favorites.

Precondition:

- ✓ The summarized station list is switched off in the settings.

1. Tap .
2. Tap the cursor to press and slide to the frequency band and release at the desired frequency.
Or: tap a point on the frequency band. The cursor automatically jumps to the corresponding frequency.
The station at the set frequency will be tuned.

Select from station list (FM/DAB)

The station list displays the stations that currently can be received. The station list updates automatically.

1. Open the station list.
2. Tap the desired station.
The selected station will be tuned. The best reception mode is selected automatically depending on station availability.

Searching for and filtering stations (Internet Radio)

In Internet Radio mode, stations can be filtered according to category or searched for using a full-text search.

1. To start the full-text search, tap .
2. Enter the name of the desired station.
The list of the found stations updates automatically during input.
3. Tap the desired station.

SCAN Search in SCAN mode (FM/DAB)

In SCAN mode, the stations in the frequency band are set automatically in succession and played for approx. 5 seconds each. SCAN mode is only possible in the additional window in which the current playback is displayed.

1. To start SCAN mode, tap SCAN.
SCAN mode starts and the current station is shown on the display.
The SCAN function key is shown.
2. To select a station, tap SCAN.
The SCAN function key is no longer highlighted.
SCAN mode stops and the station is tuned.

Storing stations on the station preset buttons

You can save up to 36 stations from different frequency bands and reception modes as favorites on the station preset buttons.

1. Tune the desired station.
2. Tap .

Or: tap and hold the station on the station list.

The station preset buttons are displayed.

3. Tap .

Or: tap on an already occupied station preset button and hold for approx. three seconds.

The station is saved on the selected station preset button.

If a station was already saved on the station preset button, this station will be removed from the station preset button and replaced by the new station.

Special functions in radio mode

 Refer to   and  *Safety instructions*.

The special functions in radio mode listed below may not be available for all Infotainment systems, depending on the vehicle equipment, and may not be available in all countries.

Internet radio

Internet Radio is a reception mode for Internet Radio stations and podcasts independent of FM and DAB. Due to its transmission over the internet, receipt is not regionally limited.

Internet radio is only available if the Infotainment system has an active Internet connection. Costs for streaming data online may result when using Internet radio.

 This function of the Internet Radio in some countries depends on your vehicle privacy settings.



Station logos

Station logos can be preinstalled for some frequency bands in the Infotainment system.

If the Automatic station logo selection function is activated in the settings, the station logos are automatically assigned to the stations.

In Internet radio mode, the Infotainment system obtains the station logos from an online database and assigns them automatically to the stations.

Assigning station logos manually

1. In radio mode, tap  ► Radio ► Station logos.
2. Select the station to which a station logo should be assigned.
3. Select the station logo.
4. This process can be repeated for additional stations.
5. To finish assigning station logos, tap .

Online functions in radio mode

 Refer to   and  *Safety instructions*.

Depending on the vehicle equipment, the Infotainment system features online functions in radio mode.

Online functions in radio mode are not available in all countries and vehicle models.

Online functions in radio mode include Internet Radio, for instance.

Prerequisites for using online functions in radio mode:

- ✓ The vehicle is equipped with VW Car-Net.
- ✓ You have registered and you have an active VW Car-Net user account.
- ✓ The vehicle is assigned to your VW Car-Net user account.
- ✓ You have purchased a corresponding active data package for an Internet connection and have also purchased a "Plus Online Radio subscription" via the VW Car-Net app or the VW Car-Net website, USA: vw.com/carnet, Canada: vw.ca.

SiriusXM

 Refer to   and  *Safety instructions*.

SiriusXM is a satellite radio station that can be received in the USA and Canada. Satellite radio services are subject to fees and must be enabled for the Infotainment system by phone or online.

SiriusXM subscriptions can be activated via cell phone.

The current status of the subscription can be shown in the settings in satellite radio mode.

Additional information can be found on the Internet:

In the USA:

www.siriusxm.com

In Canada:

www.siriusxm.ca

Displaying the SiriusXM ID

Each radio has its own SiriusXM ID with which you can manage your subscription.

1. In satellite radio mode: Tap  ► Subscription Information.

Or: in radio or media mode, tap  ► Radio ► Subscription information.

Or: In satellite radio mode: Tap  and enter channel number "0".

The SiriusXM ID, the website and phone number for the SiriusXM activation hotline will be displayed on the screen.

SiriusXM with 360L

Your vehicle can be equipped with SiriusXM with 360L. SiriusXM with 360L offers both satellite and streaming connectivity for a multitude of music, news, sports, and entertainment channels and content. With SiriusXM with 360L, you have a personalized listening experience with recommendations and functions based on your listening habits.

SiriusXM live channels

The channels available depend on the enabled services. All available channels are displayed in the channel list.

Each channel is assigned a channel number.

The channels are sorted in the channel list according to their channel number. The channels can be opened directly via their channel number under .

All channels are sorted according to categories. Within the categories, the channels are sorted according to genre. Channels can be browsed in categories, e.g. music.

Setting SiriusXM live channels

Available channels can be set in various ways depending on the vehicle equipment.

1. In satellite radio mode: Tap  and set the preferred channel using the channel number.

Or: Tap the title image of the preferred channel.

Or: turn the knob, select the preferred channel and press it.

2. *Optional:* To search for channels with content related to the content currently being played, tap Related in the station display.

A list with related content will be displayed.

On Demand

SiriusXM with 360L offers access to a multitude of on-demand content, e.g. concerts.

Opening on-demand content

1. Select a channel category, e.g. music, and select a genre, e.g. rock.

2. Tap On Demand.

3. *Optional:* To search for on-demand content related to the content currently being played, e.g. shows, tap Related in the station display.

A list with related content that is currently playing will be displayed.

Live Sports

With the category of "Live Sports", you can call up transmissions of games that are being aired on SiriusXM.

Opening Live Sports

1. Select the category "Live Sports".

2. Select the preferred transmission of a game.

Play Ahead Controls

With the "Play Ahead Controls" function, both live and on-demand content can be played and paused, and you can jump forwards or backwards in the playback.

Presets

SiriusXM live channels and on-demand shows can be saved as a preset. Up to 36 presets can be saved.

Saving SiriusXM content as Presets

1. To save a live channel currently being played back or an on-demand show currently being played back as a preset, press and hold a preset bank.

Or: In the channel list or the list of on-demand shows, press and hold the preferred content and select a preset bank.

Listening profile

The personalized listening profile saves recommendations based on the program content currently being listened to and the latest listening history, and is regularly

updated.

The listening profile can be set up in the Volkswagen user account and used with the SiriusXM app.

Setting up a listening profile

1. In satellite radio mode: To create a new listening profile, tap  in the station view.

Or: tap  ► Radio ► Set up new listening profile in radio or media mode.

Personalized SiriusXM recommendations

A collection of personalized SiriusXM recommendations is available for each listening profile.

The personalized SiriusXM recommendations are regularly updated, based on what you're listening to.

Displaying personalized SiriusXM recommendations

1. Tap For You.

Listening history

For each listening profile, a list of SiriusXM content recently listened to is displayed. This listening history can be displayed and reset at any time.

HD Radio

 Refer to   and  *Safety instructions*.

HD Radio is a digital radio station that can be received in the USA and Canada.

HD Radio Technology

Some AM and FM radio stations also transmit their content digitally via HD Radio Technology.

When the function is activated in settings in the AM or FM band and the current station supports HD Radio Technology, the  function key appears on the Infotainment system display. The Infotainment system switches automatically between digital and analog reception depending on the reception quality. If the station is currently received in analog mode, the function key is grayed out.

Some stations offer additional substations via HD Radio Technology (multicast programming). If this is the case, HD1 is displayed after the station frequency of the main station. Substations are marked with HD2, HD3, etc.

Tuning the HD Radio Substations

1. Tap  ► to cycle through the available substations.

Or: Select an additional station from the station list.

Or: to cycle through the additional stations individually, tap < or >.

The substation that is currently selected is displayed after the main station on the screen (for example ... HD3 for the second substation).

 The available substations of the current stations are displayed on the station list.

Additional HD Radio Technology services

1. To select your chosen additional service, tap View.

HD Radio Emergency Alerts

The "HD Radio Emergency Alerts" function can be used to receive reports of unusual, potentially life-threatening events, such as natural disasters. These notifications are played as pop-up notifications while the radio is on. This function is activated in the factory.

If you tap Remind me later when a notification appears, the notification will appear again about ten minutes later. If you tap Close, the notification will be moved to the Alert list. If the "HD Radio Emergency Alerts" function is deactivated, these notifications are moved directly to the Alert list and indicated by  and a number in the status bar. The number on the symbol displays the number of notifications.

Activating or deactivating HD Radio Emergency Alerts

1. In radio mode, activate or deactivate  ► Radio ► Emergency notifications.

Opening the Alert list

Up to five notifications can be displayed in the Alert list.

1. Tap  in radio mode.

Media mode

Introduction

In media mode, you can play back media files from data carriers in the Infotainment system.

Depending on the vehicle equipment, the following data carriers can be used:

- USB storage medium, e.g. USB flash drive.
- Bluetooth device, e.g. cell phone.

Depending on the vehicle equipment, the following types of media files can be played:

- Audio files, e.g. music.
- Video files.

Restrictions and instructions for data carriers

Dirty, overheated or damaged data carriers are not to be used. Read and heed the information provided by the manufacturer.

Difference in quality between data carriers from different manufacturers can cause problems with media playback.

Wrong configuration of data carriers can lead to the data carriers being unreadable.

The storage volume, condition (copy and delete processes), file system, folder structure and the amount of saved data can increase the time taken to read data carriers.

Playlists only define the order of play and refer to the saved location of the media files within the folder structure. No media files are saved in playlists. To play a playlist, the media files must be present in the data storage device memory location, to which the playlist refers.

 **Volkswagen is not responsible for damaged, altered or lost files on data carriers.**

Functions and media symbols

















 Refer to  and  *Safety instructions.*

Audio, media, connectivity

The available scope of functions and possible media formats depend on the vehicle equipment and are not available in all countries.

- Media playback and media control via Bluetooth.
- Audio playback in these formats:
 - AAC.
 - APE.
 - ALAC.
 - FLAC.
 - MP2.
 - MP3.
 - MP4.
 - Vorbis.
 - OPUS.
 - WMA.
 - WAV.
- Video playback in these formats:
 - MPEG-1 and MPEG-2 (.mpg, .mpeg, .mkv, .avi).
 - ISO MPEG-4 ASP; Xvid (.mp4, .m4v, .mov, .mkv, .avi).
 - ISO MPEG-4 AVC/H.264 (.mp4, .m4v, .mov, .mkv, .avi).
 - Windows Media Video 9 (.wmv, .asf, .mkv, .avi).
- Cross-device playlists.
- Cross-source media database:
 - Data from all media sources connected to the Infotainment system are stored in a media database.
- Media search.

General symbols for media operation

1. To open the main menu, open the home screen and tap   ⇒ *Overview and controls of the 12" version*, ⇒ *Overview and controls of the 10" version*.
 Open current playback.  Start replay.  Pause replay.  Go to the previous track.  Skip to the next track.  Repeats the current track.  Repeat all tracks.  Activate random playback.  Display favorites list.  Add media file to favorites list.  Top right: Select media source.  Opening the settings.  Open Search.  Go back one folder level in the media source.

Symbols for media sources

 Select My media as a media source. Connected USB devices may be selected under My media.  Select a device connected via Bluetooth as a media source.

Symbols for categories and groups of media files

Video replay symbols

 Replay video in full-screen mode.
  Minimize replay.

Selecting and playing a media source

Refer to  and  *Safety instructions*.

Selecting a media source

1. If you want playback from an external media source, connect the external media source.
2. Select the connected media source to be used for playback.

▶ Playing audio and video files

A media source must be connected and selected before media files can be played back.

There are different ways to search for and play media files from an available media source.

J≡ Searching the folder structure

All media files from USB devices are filtered by category (e.g. albums). This category view is always displayed in My Media. The classic folder structure of the individual USB data carriers can also be found in the My Media menu.

1. Tap your desired folder.

The folder structure of the selected media source is displayed. If My Media is selected, the categories (e.g. music) and connected media sources are displayed

2. Searching the folder structure for a desired track.

Or: to start the full-text search, tap .

The input line is displayed.

3. Enter the name of the desired track.

The list of the found tracks updates automatically during input.

4. Tap the desired track.

When playback starts, if the selection is located in a folder on a media source, all of the media files located in the folder will be added for playback.

If a playlist is played back, all available tracks on the playlist will be added for playback.

5. Close the selection with .

♥ Selecting from favorites

You can save individual tracks, albums, artists and genres under favorites for playback.

1. Open Favorites.

2. Tap on your favorites.

Depending on the selection, all tracks heard during the current playback will be added to favorites.

♥ Saving favorites

Only media files that are displayed in My Media in the Music and Video folders can be saved as favorites. You can save individual tracks, albums, artists and genre as favorites.

1. Start playback of the desired track.

2. Tap .

3. Tap .

Or: tap on an already occupied favorite position, and press and hold for approx. three seconds.

4. Select from the selection list, e.g. track.

The selection is saved in the selected favorite position as a favorite. If the favorite position was already occupied, the previously saved favorite is overwritten.

The selection options in the selection list depend on the data attached to the media file. If a genre is not indicated for music files, the genre cannot be saved as a favorite.

If a video file is currently being replayed, only this video can be saved as a favorite.

Entertainment playback via the Infotainment system

Refer to  and  *Safety instructions*.

The Infotainment system can play music and videos.

Video mode

In video mode, the Infotainment system display can play a video from a data carrier \Rightarrow *Selecting and playing a media source*.

The video sound is played back via the vehicle speakers.

The video image is only displayed when the vehicle is stationary. The Infotainment system display will be switched off when the vehicle is moving. The video sound will continue to be played.

In some countries, for road safety reasons, no video image is shown even when the vehicle is stationary.

Navigation

Introduction

The current vehicle position is determined by a global satellite system. In order to enable optimum navigation to your destination, all measured values and possible traffic information are compared with the available map material.

Audible navigation aids and graphic representations lead you to your destination. Audible navigation aids Acoustic navigation announcements and graphic displays lead you to your destination.

In some countries, it may not be possible to select some Infotainment system functions on the screen when driving above a certain speed. This is not a malfunction but rather compliance with legal regulations.

WARNING

Configuring settings, entering destinations and changing settings for the navigation system while driving can distract the driver and cause accidents and injuries.

- Always drive attentively and responsibly.
- Only adjust settings, enter destinations, or change navigation information when the vehicle is stationary.

 **If you missed a turn on your route, the navigation system may recalculate the route.**

 **The quality of the driving directions depends on the available navigation data and any reported traffic incidents.**

 **The corresponding VW Car-Net service needs to be activated to use online functions and mobile online services, e.g. traffic information.**

Navigation restrictions

If the Infotainment system cannot receive data from GPS satellites, for example in a tunnel, navigation will still be possible using the vehicle's sensors.

In areas that are not digitized or only partially digitized in the Infotainment system memory, the Infotainment system will still try to provide route guidance.

If navigation data is missing or incomplete, the vehicle position may not be determined accurately. This may result in navigation that is not as accurate as usual.

Routing is subject to ongoing changes, like new streets, construction zones, road closures, or changes to street names or house numbers. Using outdated navigation data can lead to errors or uncertainty when using route guidance.

Function descriptions

 **Please read the introductory information and heed the Warnings and Notice  and  Safety instructions.**

Voice guidance

Navigation messages are acoustic driving directions for the current route.

The type and frequency of navigation messages depends on the settings and the driving situation, like the start of the route guidance and whether you are driving on a highway or roundabout.

If the destination cannot be reached exactly, for example because it is not in a digitized area, there will be a navigation announcement that the Destination area has been reached. Messages about the direction and distance to your destination will also be displayed on the screen.

During dynamic route guidance, reported traffic incidents on the route are announced. There will be an additional navigation announcement if the route is recalculated due to a traffic incident or a change in driving style.

You can adjust or mute the volume during a traffic announcement. All other navigation announcements will be given at that volume or will be muted.

 **Navigation messages will not be given if the Infotainment system is muted.**

Adapting the Navigation Map

To ensure an optimum view, you can also adapt the navigation map and map view using enhanced finger movements.

Moving the navigation map

Recommendation: Use index finger.

1. Move the navigation map with your finger.

Zooming in or out on the map view

Recommendation: Use index finger.

1. Tap and hold the map twice in a row.
2. To zoom out of the map view, move your finger upwards. To zoom in on the map view, move your finger downwards.

Zooming in or out on the map view

Recommendation: Use thumb and index finger.

1. Tap and hold the map with two fingers at the same time.
2. To zoom out of the map view, slide your fingers towards each other. To zoom in on the map view, slide your fingers away from each other.

Tilting the map view

Recommendation: Use index and middle finger.

1. Tap and hold the map with two fingers at the same time, held horizontally next to each other.
2. To tilt the map view to the front, move your fingers upwards. To tilt the map view to the back, move your fingers downwards.

Rotating the map view

Recommendation: Use thumb and index finger.

1. Tap and hold the map with two fingers at the same time.
2. Turn your fingers clockwise or anti-clockwise to turn the map view.

Route plan

The route plan contains information about relevant events, such as waypoints and destination suggestions, if the relevant data is available to the navigation system

Tapping an event will open a dialog box with additional options. The options available depend on the event and the current settings.

Opening and closing the route plan

1. Tap the route plan to open.
2. To close the route plan, tap >.
3. To stop the route guidance to the destination or waypoint, tap ⊗ next to the destination in the route plan.

Editing route guidance

To edit route guidance, move the stopovers or the destination in the route plan.

1. Tap and hold the desired destination until it is visibly highlighted.
2. Move the destination to the desired position and release it.

The route will be recalculated.

Additional dialog box in the route plan

Tapping the route plan entries may cause a dialog box to open with additional options for these entries. The options available depend on the entry that is tapped.

Functions in the split screen:

Display on map Displays the selection on the map.

Direct route Starts direct route guidance.

Add waypoint Adds a waypoint to the route guidance.

Delete Delete waypoint from route guidance.

Avoid Avoid traffic disruptions. The route will be recalculated.

Stop route guidance Ends the current route guidance.

Closing an additional dialog box in the route plan

1. Tap a free area outside of the additional window.

Setting preferred POI categories

The system offers different points of interest, e.g. gas stations, using the quick select symbol when entering destinations, in the route plan and on the map. You can set priorities for how these symbols are displayed under  Basic functions ► Determine preferred POI categories.

Saved data

In order to enable you to enter destinations quickly and to optimize route guidance, the Infotainment system saves certain data, such as frequently driven routes.

Delete saved data

1. Tap  Basic functions ► Delete usage pattern.
2. Tap confirm to delete the data.

Learning usage patterns

While driving, the Navigation system saves routes traveled and destinations reached in order to create automatic destination suggestions. Destinations are learned with reference to the time of day and the day of the week.

The navigation system can suggest pre-learned routes.

1. Tap  ► Suggestions to show the suggested routes.

Selecting one of the suggested routes will cause route guidance to begin.

The route guidance follows the selected route until you deviate from it. The route will then be recalculated and will lead back to the selected route via the most direct path.

Relevant traffic disruptions are taken into consideration in route guidance. If an alternative route and the navigation data are available, relevant disruptions will be avoided.

If you are driving a pre-learned route without active route guidance, the destination is added to the route plan. Route guidance does not need to be actively started for a journey to a pre-learned destination. You are warned about traffic disruptions if necessary.

A predicted arrival time is displayed.

You can activate or deactivate this function at any time as well as delete the saved data for this function.

Activating or deactivating “Learn usage pattern”

1. To open this function's settings, tap  ► Basic functions.
2. Tap Learn usage pattern.

Deleting saved “Learn usage pattern” data

1. To open this function's settings, tap  ► Basic functions.
2. Tap Delete usage pattern.

Functions and symbols of the navigation system

 Please read the introductory information and heed the Warnings and Notice ⇒  and  Safety instructions.

Navigation





The functions and symbols of the navigation system may differ depending on the vehicle equipment and are not available in all countries.

Functions

- Entering a destination and route calculation.
- Personal destinations.
- 3D City Maps.
- Online Map Update.
- Online Traffic Information.
- Range 360 display.

General navigation symbols

1. To open the main menu, open the home screen and tap  ⇒ *Overview and controls of the 12" version*, ⇒ *Overview and controls of the 10" version*.

 Enter and search for destinations.  Display navigation map.  Open saved addresses (contact list for the connected cell phone).  Opening the settings.

Symbols on the map



The function keys and displays shown depend on the settings and the current driving situation.

Symbols for traffic information, e.g. traffic disruptions, and POIs s, e.g. gas stations, are displayed on the map if the data is available to the navigation system ⇒ *Traffic information*.

 Display current position.  Align the map.  Map scale.  Display route information.  Fully automatic map mode (orientation in direction of travel, position, zoom and tilt).  Display dialog box with route options.  Display dialog box with additional options.  Dialog box with active filter for charging stations.

Symbols in the dialog box









1. To open the dialog box with further options, tap .

 Display route overview and alternative routes to the current route guidance for the active route guidance.  Repeats the last navigation announcement.  Mute or adjust volume of navigation instructions.  Range 360 display.

Additional symbols

 Destination search: detailed destination input for an address.  Save to favorites list.  Work (company).  Home (private).





Symbols in the route plan

 Display current position.  Destination for the current route guidance.  Adds destination as a stopover or starts direct route guidance to the destination.
 Saves destination as a favorite.  Close route plan.  Predicted distance to the route destination.  Predicted arrival time at the route destination.  Predicted time to reach the route destination.

Symbols for charging stations

Charging stations are displayed on the map if the data is available to the navigation system.

To start route guidance, tap the preferred charging station ⇒ [Inputting destinations and starting route guidance](#).

 Electric vehicle charging station on the map.  Number of planned charging stops across the whole distance.  Charging time at the electric vehicle charging station.  Filter/preference settings for displaying the electric vehicle charging station on the map.  Current occupation status of the charging station.

Red status: charging station is occupied or out of order.

Green status: charging station is available and not occupied.

 Status of the high-voltage battery.

Traffic disruptions

Traffic disruptions are displayed on the map if the data is available to the navigation system ⇒ [Traffic information](#).

Tap a traffic disruption to open a dialog box with details ⇒ [Function descriptions](#).

 Traffic jam.  Accident.  Ice.  Road closed.  Slip hazard.  Danger.  Construction zone.  Strong wind.

Inputting destinations and starting route guidance

 Please read the introductory information and heed the Warnings and Notice ⇒  and  Safety instructions.

Depending on the vehicle equipment, different functions are available for inputting destinations. Some functions are only available in some countries.

The various functions for inputting destinations are located in the navigation system main menu ⇒  [Introduction](#).

You can further restrict your search with specific suggestions in the results list, e.g. “nearby”.

For further information about symbols on the Infotainment system screen, see ⇒ [Functions and symbols of the navigation system](#) in this Owner's Manual.

Enter address

Start route guidance by entering an address. During input, the navigation system suggests already known destinations. You can also enter a new, unknown address for route guidance.

 When inputting the address, input the name of the destination, not the postcode of the destination.

Selecting the destination and starting the navigation system

1. Tap .

Or: tap .

2. Enter the destination address and select your desired destination.

3. Tap Start.

Or: tap .

Quick start

1. Tap .



2. Enter the address of the destination, tap the desired destination and hold for a few seconds.

 Enter the destination as accurately as possible. If there is an error in the destination entered, route guidance cannot take place or may lead to the wrong destination.

Destination suggestions

Navigation uses saved data such as your last destinations, learned destinations, favorites, home address and work address to provide you with route guidance.

Selecting the destination and starting the navigation system

1.  Tap .

2. Tap on the desired destination.

The route guidance starts automatically.

Last destinations

The navigation system saves up to 25 of the most recent destinations to make them available for route guidance. A new destination automatically overwrites the oldest destination.

Selecting the destination and starting the navigation system

1. Tap  Last destinations.
2. Tap on the desired destination.
3. Tap Start.

Or: tap .

Quick start

1. Tap  Last destinations.
2. Tap and hold the preferred destination for a few seconds.

Favorite destinations

You can save up to 50 journey destinations as favorites.

Saving a journey destination as a favorite

1. While entering a destination, tap on  in the additional window.

Selecting the destination and starting the navigation system

1. Tap  Favorites.
2. Tap on the desired destination.
3. Tap Start.

Or: tap .

Quick start

1. Tap  Favorites.
2. Tap and hold the preferred destination for a few seconds.

Selecting on the map

The navigation map contains active areas at many points which are suitable for the input of a destination. To enter a destination, tap on your preferred position or preferred location on the map. If map data is available at this point, you can launch route guidance.

Entering a destination via the navigation map is dependent on data status and not possible for all positions.



Use the Offroad navigation system to enter a destination to a selected destination point with unknown data.

Offroad navigation

The Offroad navigation system calculates routes to selected destinations with unknown data. If the destination is not located on a known road or at a known position, the navigation system will calculate the route up to the next point on the known road and then complete the route to the destination using a straight line.

In order to start an Offroad navigation, tap on a free area without positioning data.

Starting the navigation

1. Tap .
2. Press and slide the map view until you can select your desired position. You can operate the navigation map using extended finger touches ⇒  [Introduction](#)
3. Tap the preferred destination or any destination point on the map without positioning data.
4. Tap Start.

Or: tap .

Using a contact's address data

Start route guidance via the saved address data for a contact. You cannot use contacts for whom you have not saved any address data for route guidance.

Starting the navigation

1. Tap .
2. Tap on the preferred contact and address data.
3. Tap Start.

Or: tap .

NOTICE

If the address data for your contact is out of date, the route guidance will nevertheless direct you to the stored address. Please ensure the address for your contact is up to date.

Setting a 360° range display and Electric Vehicle Route Planner

 Please read the introductory information and heed the Warnings and Notice ⇒  and  Safety instructions.

Range 360 display

The Range 360 view shows the possible range based on the current charge level in the high-voltage battery.

The image only displays an estimated range, taking into consideration current consumption values. The image may change during the journey and the upper and lower limits of the range must be seen as an estimate.

Activating and Deactivating the 360° Range Display

1. Tap  .

 To show the complete range display on the map, adjust the map view if necessary ⇒  [Introduction](#).

Electric Vehicle Route Planner

A maximum of five charging stations can be added automatically as charging stops.

You can specify the preferred payment type at charging stations in the dialog box with route options ⇒ [Functions and symbols of the navigation system](#). If your preferred payment type is not available at one or several charging stations, audible information is provided. Depending on what you have selected and the available data, suitable charging stations are displayed on the map and prioritized in the itinerary.

In the dialog box with route options, you can also set your preferred remaining range with which you would like to arrive at the charging stations along the route and at the destination ⇒ [Functions and symbols of the navigation system](#). What is entered here influences the automatic planning for charging stations required along the route.

The settings in the “Charging to the maximum battery charge level” menu can be temporarily overwritten by the “Electric Vehicle Route Planner” function ⇒ [Overview of the charging settings](#).

After completion of route guidance, the settings in the “Charging to the maximum battery charge level” menu will be used again.

The current occupation status of charging stations, if available, is shown in the Infotainment system if there is an active Internet connection ⇒ [Functions and symbols of the navigation system](#). The current status is displayed with a colored dot at the edge of the symbol.

Automatically adding charging stops

1. In the navigation settings, tap ⇒  [Introduction](#) Route guidance ▶ Route options ▶ Add charging stops automatically and activate it to activate the automatic scheduling of necessary charging stations along the route.

Selecting alternative charging stations

With planned routes, you can select alternative charging stations instead of the ones automatically mapped along the route.

1. Enter or select your preferred destination.
2. Tap Start.
3. Open route plan.

4. Tap a scheduled charging station in the route plan.

Details of the planned charging station are displayed.

5. Tap Display further charging stations.

The positions of further charging stations nearby are displayed on the map.

6. Tap an alternative charging station nearby on the map or in the list.

Details of the alternative charging station are displayed.

7. Tap Add destination as a stopover.

The charging station previously planned in is replaced by the newly selected charging station and the route is adjusted.

 If Add as a stopover is selected, the selected charging station is retained even if the route is changed.

Searching for Charging Stations with a Filter

Various criteria can be set to search for charging stations on the map or in the search results of the “Charging station” category. If a criterion is set, this has an effect on the presentation on the map. Only the charging stations corresponding to the criteria are displayed. The search results for the “Charging station” category are filtered according to the selected criteria. The criteria can be changed again at any time. An active filter has no influence on route planning. To consider charging stops in route planning, adjust the settings ⇒ [Inputting destinations and starting route guidance](#).

 An active filter is displayed by a colored dot in the dialog box ⇒ [Functions and symbols of the navigation system](#).

Navigation data

 Please read the introductory information and heed the Warnings and Notice ⇒  and  [Safety instructions](#).

The Infotainment system is equipped with an internal navigation data storage medium. Depending on the country, the required navigation data may already be installed.

The Infotainment system always requires up-to-date navigation data to ensure that route guidance can be implemented correctly and that the functions provided are fully available.

NOTICE

If you use outdated navigation data, there may be adverse effects on the navigation system. It may not be possible to determine up-to-date routes, or route guidance may guide you to an incorrect destination.

- Always ensure that your navigation data is kept up-to-date.

Navigation Data Online - Additional Information

Regions in the navigation data that you do not use can be removed from the system under certain circumstances, e.g. navigation data memory low on space. If you subsequently need these regions again at a later time, the navigation system will download them again on request. No contract for mobile online services is needed. This service depends on the vehicle equipment and is only available in some countries.

1. Switch the ignition on.
2. Establish an Internet connection if you have not already done so.

Navigation data is automatically updated in the background.

Updating navigation data manually

Up-to-date navigation data for larger regions, such as Western Europe, can be downloaded online at www.volkswagen.com and stored on a suitable USB data carrier, available to buy in stores. If the Infotainment system is switched off during the process, installation will be interrupted and it will continue automatically once the system is turned on again.

1. Download and save the navigation data onto a USB data storage device.
2. Switch the vehicle ignition on.
3. Link the USB data carrier to the Infotainment system when the vehicle is stationary.

The navigation data for frequently driven regions is automatically updated in the background.

 **While and after updating the navigation data, no message appears in the Infotainment system.**

 **If you update the navigation data manually, the USB data carrier must remain permanently connected. You will not receive a notification when the update is complete.**

 **Do not disconnect the USB data carrier from the Infotainment system for a few days until the navigation data for visited regions has been fully downloaded and installed. The installation will start automatically in the background during the journey. Doing so will cancel the update process. If you disconnect the data carrier and visit a new region, the navigation data is not updated due to the lack of a USB data carrier.**

Displaying the map data version

1. Tap **(HOME)** ▶  ▶ System information.
- Or: tap **(MENU)** ▶  ▶ System information.

Traffic information

 **Please read the introductory information and heed the Warnings and Notice ⇒  and  Safety instructions.**

Depending on the vehicle equipment, the reception of traffic information may not be available in all Infotainment systems or in all countries.

The Infotainment system automatically receives detailed traffic information when there is an active Internet connection. This information is displayed on the map via symbols and color coding on the road network.

 **Reception of traffic information is possible in some countries if permitted by the privacy settings selected. No traffic information is received in offline mode.**

Traffic disruptions

Traffic disruptions such as traffic jams are displayed on the navigation map as symbols ⇒ *Functions and symbols of the navigation system*.

The route plan displays current traffic disruptions if the relevant data is available to the Navigation system.

If route guidance is active, traffic disruptions on the current route will be displayed on the route plan. You can avoid these traffic disruptions by modifying the route plan.

Avoiding traffic disruptions

1. Tap the traffic disruption.
2. Tap Avoid.

The route will be recalculated.

 **Only one traffic disruption can be avoided in this manner for each route guidance.**

 **Local warnings, e.g for severe weather, can be played via the Infotainment system as a pop-up notification.**

Traffic flow display

The traffic flow for current traffic disruptions is displayed on the navigation map via color coding on the road network.

Mobile phone interface

Introduction

Using the phone interface, you can connect your cell phone to the Infotainment system and control the phone functions via the Infotainment system. The sound is played back via the vehicle speakers. You can connect up to two cell phones to the Infotainment system at the same time ⇒ *Coupling, connecting and managing*.

The functions depend on the vehicle equipment, are not available in all countries and depend on the cell phone used and its operating system.

High speeds, poor weather and road conditions, a lot of background noise, even outside the vehicle, and the network quality can impair phone calls in the vehicle.

The phone interface may contain an antenna amplifier that improves the reception quality of the cell phone.

 **You generally only need to pair a device like a cell phone once. You can reestablish the device's connection to the Infotainment system at any time via Bluetooth or Wi-Fi without re-pairing your device.**

 **For a phone call via the hands-free system or at a high volume, a conversation may also be heard by third parties outside the vehicle.**

Locations with special regulations

Switch off the cell phone and phone interface at locations where there is a risk of explosions. These locations are not always clearly identified. These include, for example:

- Areas near pipes and tanks containing chemicals
- Lower decks in ships and ferries
- Areas near vehicles powered by liquefied petroleum gas, such as propane and butane.
- Areas with chemicals or particles in the air, such as flour, dust, or metal powder
- All other locations where the engine, the vehicle's drive system or the cell phone must be switched off.

WARNING

In potentially explosive environments, e.g. in the vicinity of gas stations and at other similar locations with specific regulations, ignition sparks caused by electrostatic discharge or cell phones, for example, can cause an explosion or a fire and lead to serious or fatal injuries.

- Switch off the cell phone and phone interface at locations where there is a risk of explosions, e.g. in the vicinity of gas stations, and locations with specific regulations.
- Do not use the cell phone and phone interface at locations where there is a risk of explosions, e.g. in the vicinity of gas stations, and locations with specific regulations.

NOTICE

Radiation from cell phones that are switched on can interfere with sensitive technical and medical devices, potentially causing malfunctions or damage to the devices.

- Always switch off the cell phone in areas with special regulations relating to or prohibiting the use of cell phones.

Types of phone interface

Depending on the country and vehicle equipment, your vehicle may have the following mobile phone interfaces:

- Phone interface basic configuration.

The phone interface uses the Hands-Free Profile (HFP) Bluetooth profile for transmission. This enables the use of phone functions via the Infotainment system and played back via the vehicle speakers.

- Convenience phone interface.

Just like the basic configuration of the phone interface, the Convenience phone interface uses the HFP Bluetooth profile.

The Convenience phone interface can be equipped with the wireless charging function ⇒ *Charging Options for Mobile Devices*. In order to use the features of the wireless charging function, you need to place a suitable cell phone correctly in the storage compartment. Depending on the vehicle equipment and cell phone compatibility, the cell phone connects to the vehicle antenna when you place it in the storage compartment. This improves reception and call quality.

Functions and symbols of the phone interface

 **Please read the introductory information and heed the Warnings and Notice ⇒  and  Safety instructions.**

The range of functions and the symbols may differ depending on the vehicle equipment and are not available in all countries. The available functions depend on the cell phone used and its operating system.

Functions

- Hands-free system.

- SMS functions via Bluetooth:
 - Read SMS.
 - Write SMS, inc. templates.
 - Have an SMS read out.
 - Message thread.
- E-mail functions via Bluetooth:
 - Read e-mail.
 - Write e-mail.

Symbols in the main menu

1. To open the main menu, open the home screen and tap ⇒ *Overview and controls of the 12" version* , ⇒ *Overview and controls of the 10" version* .

Open contact list. Open incoming and outgoing calls lists. Dial telephone number. Open messages (SMS and, depending on your country, e-mail). Select the active device from two or more connected cell phones. Opening the settings.

Symbols for telephone calls

Handle and display a call. End or decline a call. Mute the hands-free system. Put a call on hold. Decline a call with a SMS template. Add participants to a phone conference or begin a phone conference. Make an emergency call (SOS). Receive breakdown assistance. Voice mail. Receive information about Volkswagen and various value added traffic and travel services.

Symbols in the contact list

1. To open the contact list, tap .

Input to search for contacts. Address. Editing favorites. Add favorites. Remove favorites.

Call list symbols

1. To open the call lists, tap on .

Received incoming call. Outgoing call. Missed call. Frequent calls or favorites from your cell phone, if supported by your cell phone. Telephone number (company). Telephone number (private). Cell phone number. Fax device. Fax device (company). Fax device (private).

Text message symbols

1. To open the text messages, tap on .

Top left: Select active input. Received text message. Sent text message. Template for text messages.

Coupling, connecting and managing

Please read the introductory information and heed the Warnings and Notice ⇒ and Safety instructions.

To use the phone interface functions, pair a cell phone with the Infotainment system.

You can connect up to two cell phones to the Infotainment system at the same time. However, only one device is active at a time and can be used to make calls. The second connected device can receive calls via the Infotainment system and be used to play media.

The available functions depend on the cell phone used and its operating system.

The function is only available for cell phones that support Bluetooth (version 2.1 or above).

Pairing a cell phone

Before connecting for the first time, you need to pair the cell phone with the Infotainment system. A user profile is then automatically saved in the Infotainment system. The coupling process may take a few minutes.

Requirements:

- ✓ Bluetooth is activated on the cell phone.
 - ✓ Bluetooth is activated on the Infotainment system.
1. Open the list of available Bluetooth devices on your cell phone and select the device name for the Infotainment system.
 2. Pay attention to messages on the cell phone and in the Infotainment system and confirm these if necessary.
 - If the pairing is successful, the data on the cell phone will be saved in the user profile.
 3. *Optional:* Confirm the message for transferring the data on the cell phone.

WARNING

If you carry out the coupling when driving, this may cause accidents or injuries.

- Only carry out the coupling when the vehicle is stationary.

Connecting a cell phone

Precondition:



- ✓ A cell phone is paired with the Infotainment system.

1. Activate Bluetooth in the cell phone.

Connection management

Precondition:

- ✓ The cell phone is paired and connected.

1. Tap   Mobile devices.
2. Tap to connect the desired technology.

Active and passive connection

In order to use the phone interface functions, at least one cell phone must be connected to the Infotainment system. If several cell phones are connected to the Infotainment system, you can switch between an active and an inactive connection. In order to operate the phone interface with your preferred cell phone, establish an active connection to the Infotainment system.

Difference between the types of connection

ActiveThe cell phone is paired and connected. You can carry out phone interface functions using data from this cell phone. **Passive**The cell phone is paired and connected. You can only take incoming calls via the mobile phone interface. Other functions are not available.

Paired cell phones are saved in the Infotainment system even if they are not currently connected.

Change connection type (inactive to active)

Precondition:

- ✓ Several cell phones are connected to the Infotainment system simultaneously.

1. Tap .

The actively connected cell phone is highlighted.



2. Tap the name for the preferred cell phone.

The connection with the other cell phones will be inactivated automatically.

User profiles

An individual user profile is automatically created for each paired cell phone. Data from this cell phone, e.g. contact data, is stored in the user profile. A maximum of ten user profiles may be saved in the Infotainment system simultaneously.

Deleting a user profile

1. Tap  .

The user profiles are located in the Select cell phone area or in Mobile devices.

2. Tap the desired user profile and tap  to delete.

Calling and sending text messages

 Please read the introductory information and heed the Warnings and Notice  and  Safety instructions.

Using a phone

Select a telephone number to make a call. Various functions are available for selecting a telephone number.

Using contact data

If a contact has multiple telephone numbers, you must select the number you wish to call accordingly.

1. Tap .

2. To search for a contact, tap  and enter the name of the contact.

Or: To call a favorite, tap Favorites.

Or: Tap All.

3. Tap on a contact in the list to make the call.

 When searching for a contact, enter the last name and first name separated by a space.



Using a call list

The mobile phone interface stores the incoming and outgoing calls on a call list. Recently used telephone numbers are saved under favorites. Make a call via the call list.

1. Tap  and filter entries in the call list, e.g. by missed calls.

2. Tap on a number or, where applicable, a contact in the list to make the call.

Manually entering the telephone number

1. Tap  and enter a telephone number.
2. Tap  to make the call.

 While you are entering a telephone number, the contact related to the number is displayed on the Infotainment system screen.

Sending text messages

Depending on the cell phone and the Infotainment system in use, you can send and receive SMS text messages and, depending on your country, e-mails via the phone interface.

Sending and receiving e-mails is also dependent on the app used on the cell phone.

Sending an SMS

1. Tap  SMS ► New message and enter the message.
2. Enter the desired contact in the search bar.
3. Tap OK to send the message.

Sending an e-mail

1. Tap  E-MAIL and enter the message.
2. Enter the desired contact in the search bar. If required, a contact can be searched for using Search for contact.
3. Tap OK to send the message.

Switching between SMS and e-mail

To send an e-mail or SMS, activate the relevant option. The active option is displayed on the screen, e.g. SMS.

1. Tap .
2. Tap the desired option.

Phone directory, favorites and speed dial keys

 Please read the introductory information and heed the Warnings and Notice  and  Safety instructions.

Phonebook

This first time a cell phone is paired with the Infotainment system, the phonebook is saved in the Infotainment system. If necessary, confirm the transfer on the cell phone.

Depending on the vehicle equipment, you can save up to 5000 contacts in your phonebook.

The phone directory is updated after each new connection. During the update, the present phone directory can still be used.

If teleconferences are supported, the phonebook can be opened during a phone call and another participant can be added to the phone call.

If an image is stored for the contact, it can be displayed in the list next to the entry.

Favorites and speed dial keys

A speed dial key can be assigned with a favorite from the phone directory. If the entry contains an image, this is displayed on the speed dial key.

Speed dial keys must be programmed manually and are assigned to a user profile  [Coupling, connecting and managing](#).

Programming a speed dial key

1. Tap .
2. Tap a contact in the phone directory. If a contact has multiple telephone numbers, tap a number on the list.

Editing the speed dial key



1. Tap and hold the speed dial key until the phonebook opens.
2. Tap the new contact in the phone directory. If a contact has multiple telephone numbers, tap a number on the list.

Calling a favorite

1. Tap a programmed speed dial key.

 Favorites are not automatically updated. If the phone number for a contact changes, the speed dial key must be reassigned.

Deleting a favorite from the speed dial key

1. Tap Favorites ► .
2. To delete a favorite, tap the preferred speed dial key .

Voice control

 [Introduction to usina voice control](#)

With voice control, you can have certain functions carried out by voice command.

Types of voice control

Depending on which language has been set in the Infotainment system, one of the following voice controls will be available in the vehicle:

- Command-based voice control (standard).
- Enhanced voice control (offline or online).

Speech recognition for individual seating positions

Additional microphones enable voice control to recognize whether the driver or passenger is speaking. For supported languages, you can open functions for individual seat positions, for example switching on the seat heating.

Does my vehicle have voice control?

If there is a Talk button  on the multi-function steering wheel or your vehicle understands the activation word, voice control is installed in the vehicle.

 **In black with blue background: Voice control is active and recognizes spoken words.**

 **Test voice control before a journey to get to know the function.**

Differences in the voice controls

Command-based voice control (standard)

Only grammatically correct voice commands are recognized by the voice control. Voice commands must follow a fixed syntax in order to be recognized correctly, e.g. "Navigate to [city, street name, house number]". You can find further examples in the Infotainment system. The command-based voice control can be carried out in any available language.

Enhanced voice control (offline or online)

Speech commands can be freely worded in common speech. For example, in response to the question "How long is left to drive?", the system gives the remaining time until arrival at the destination. Suggestions for voice commands depend on the set language and can be found in the Infotainment system.

Enhanced voice control works both online and offline. By evaluating voice commands, online mode offers improved POIs, media and online radio station search functionality. Additionally, messages can be dictated. For online mode, you need a VW Car-Net contract valid for the vehicle.

 **If enhanced voice control is available in your language, it is used to activate voice control.**

Supported languages

The number of languages available in your country depends on the vehicle equipment.

Start voice control by saying the activation word available in your country ⇒ *Activation word*.

Starting and ending voice control

Voice commands

Voice control only recognizes voice commands in the language selected in the infotainment system.

Observe the following tips for successful voice commands:

- ✓ Speak clearly and at normal volume. Speak a little louder at higher speeds.
- ✓ Avoid excessive emphasis and strong accents.
- ✓ Do not leave long pauses in speech.
- ✓ Avoid external and background noise.
- ✓ Do not direct the air flow from the vents towards the microphone or headliner.

Open suggestions for speech commands

1. Tap   .

 **To ensure that names in the phonebook are identified correctly, you may need to switch the order of the first and last names of the desired contact, depending on how the phonebook entry is structured.**

Starting voice control

You can use different methods to start voice control, depending on the vehicle equipment:

- Start via speech: Say the activation word ⇒ *Activation word*.
- Start via multi-function steering wheel: Press the Talk button .

 **Depending on cell phone and operating system, voice control of a connected cell phone can be started by pressing and holding  ⇒ *App-Connect*.**

Ending voice control

You can use different methods to end voice control, depending on the vehicle equipment:

- End via speech: To open suggestions for a voice command to cancel, tap (HOME) ► (?) ► (🗨️) ► General.
- End via the multi-function steering wheel: press the Talk button (🗨️).
- End automatically: If you use functions within the Infotainment system, activate the parking system; if telephone calls or tasks involving speech and navigation warnings occur, the voice control ends automatically.

Activation word

In the ring memory of the Infotainment system, the words spoken in the vehicle are checked for the activation word. If the Infotainment system detects the activation word, voice control will begin. A ring memory is automatically overwritten approximately every 15 seconds. There is no transmission of data or words spoken in the vehicle. The ring memory is inactive when the activation word is switched off.

Switching activation word on and off

If the activation word is switched off, voice control cannot be activated via the activation word.

1. Tap (HOME) ► ⚙️ ► Voice control ► Activation word.

Speaking and recognizing the activation word

Precondition:

- ✓ The Activation word is switched on in the settings.

(USA) Hello ID. (CDN) Bonjour ID. (MEX) Hola ID.

Troubleshooting

Voice control is not responding

- Voice control is not available in your language.
- Set the correct system language in the Infotainment system.
- Start voice control by using the activation word or the Talk button on the multi-function steering wheel.
- Voice commands are not recognized due to a system error. Contact suitably qualified professionals for assistance. Volkswagen recommends contacting an authorized Volkswagen dealer or authorized Volkswagen Service Facility.

Voice control is giving unsuitable responses

- Voice control has misinterpreted the question.
- Clearly give your voice command again.

Voice control is not performing the function

- This function cannot be performed by voice control.
- The function is not available in all languages. You can find suggestions for voice commands in the set language in the Infotainment system.
- Settings within the function are preventing the device from switching on or carrying out the function.
- Voice control did not understand the voice command.
- There is insufficient data.

Transporting

Stowing luggage and cargo

Stowing luggage securely in the vehicle

- Distribute luggage as evenly as possible in the vehicle. Do not cover any vent openings.
- Always stow luggage and heavy objects in the luggage compartment and place them as far forward in the compartment as possible ⇒ .
- Adhere to the Gross Axle Weight Rating and Gross Vehicle Weight Rating ⇒ [Technical data](#).
- Secure objects in the luggage compartment using suitable securing cords, fixation belts or tensioning straps on the tie-downs.
- Also store small objects securely.
- If necessary, fold the rear seat backrest down and lock it securely.
- If necessary, adjust the headlight range. Vehicles with dynamic headlight range control will adjust automatically.
- Adjust the tire pressure based on the load. Follow the tire pressure label ⇒ [Checking the tire pressure](#).

WARNING

Objects or animals that are not secured or are secured incorrectly can cause serious injuries or death in the event of sudden driving and braking maneuvers or a collision. This is especially true if the airbags deploy and strike objects, causing them to fly through the vehicle interior.

- Store all objects securely in the vehicle. Follow the legal regulations whilst doing so.
- Stow objects in the vehicle interior in such a way that they will not enter the airbag deployment zone while you are driving.
- Secure animals in the vehicle restraint systems that are appropriate for their weight and size.
- Always keep the storage compartments closed while driving.
- Do not leave hard, heavy, or sharp objects loose in the open storage compartments in the vehicle, on the surface behind the rear seat backrest, or on the instrument panel.
- Remove hard, heavy, or sharp objects from clothing and bags in the vehicle interior and store them securely.

WARNING

If objects stowed in the vehicle cause people to sit in the wrong position, serious or fatal injuries may occur in the event of sudden driving and braking maneuvers or accidents.

- Never stow objects on a seat if a person is going to use it.

WARNING

When transporting heavy objects, the vehicle's handling performance may change because of the altered center of gravity and the braking distance may increase. Heavy loads that have not been stowed or secured properly may change the vehicle handling, e.g. if the load slides around. This can result in a loss of vehicle control and lead to serious or fatal injuries.

- Never overload the vehicle. Both the load and the distribution of the load in the vehicle affect driving behavior and braking efficiency.
- Always distribute the load evenly and as low down in the vehicle as possible.
- Secure heavy objects in the luggage compartment as far in front of the rear axle as possible.
- Secure any loose objects to prevent them from sliding around.
- Always adapt your speed and driving style to the visibility, weather, road and traffic conditions.
- Accelerate with extra care and caution.
- Avoid sudden braking or driving maneuvers.
- Brake earlier than usual if the vehicle has a heavy load.

NOTICE

Abrasive objects on the rear windows can cause damage, for example to the heating elements for the rear window defroster.

- Do not load the luggage compartment to a height where objects rest against the rear window.

NOTICE

Carrying systems fixed to the rear spoiler may damage the vehicle.

- Do not attach a luggage rack or any other kind of carrying system, e.g. bicycle rack, to the vehicle's rear spoiler.

Luggage compartment cover

Luggage compartment cover

When opening and closing the trunk lid, the luggage compartment cover is raised or lowered on the attached retaining straps.

The luggage compartment cover is not suitable for use as storage for objects, even lightweight items of clothing ⇒ ⚠.

⚠ WARNING

Objects or animals on the luggage compartment cover can damage the luggage compartment cover and cause serious injury or death in the event of sudden driving and braking maneuvers or an accident.

- Never transport objects on the luggage compartment cover.
- Never allow animals to ride on the luggage compartment cover.

ⓘ NOTICE

Incorrect handling of the luggage compartment cover can cause damage.

- Do not load the luggage compartment so high that the luggage compartment cover presses on the load when the trunk lid is closed.
- Never close the trunk lid while the luggage compartment floor is open or locked.

Installing and removing the luggage compartment cover

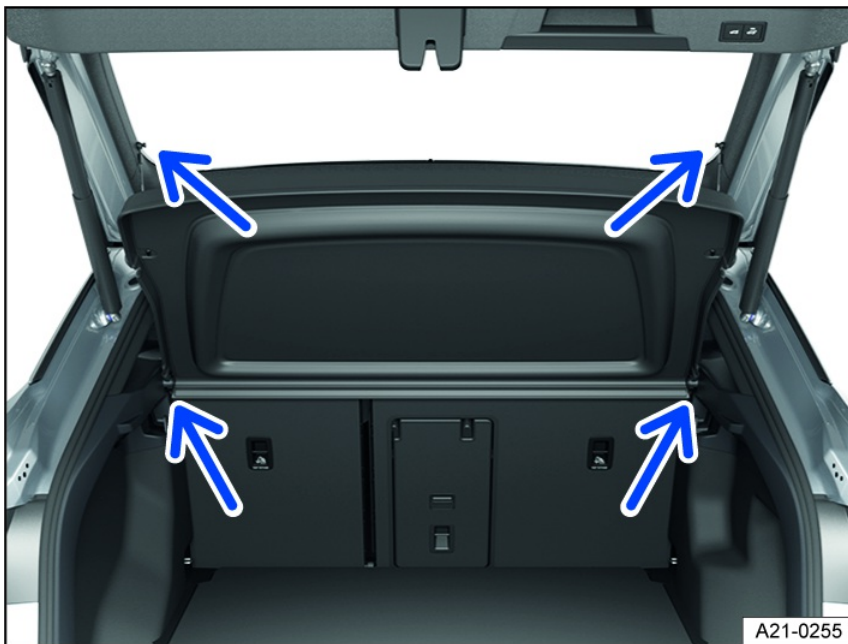

Fig. 115 In the luggage compartment: Installing and removing the luggage compartment cover.

Removing the luggage compartment cover

1. Unhook the top retaining straps from the trunk lid *fig. 115* (upper arrows).
2. Lift the trunk lid.
3. Press the luggage compartment cover out of the lateral brackets in the luggage compartment *fig. 115* (lower arrows).

Installing the luggage compartment cover

1. Press the luggage compartment cover into the side holders in the luggage compartment *fig. 115* (lower arrows).
2. Hook the retaining straps onto the trunk lid *fig. 115* (upper arrows).

Luggage compartment floor

Opening and closing the luggage compartment floor

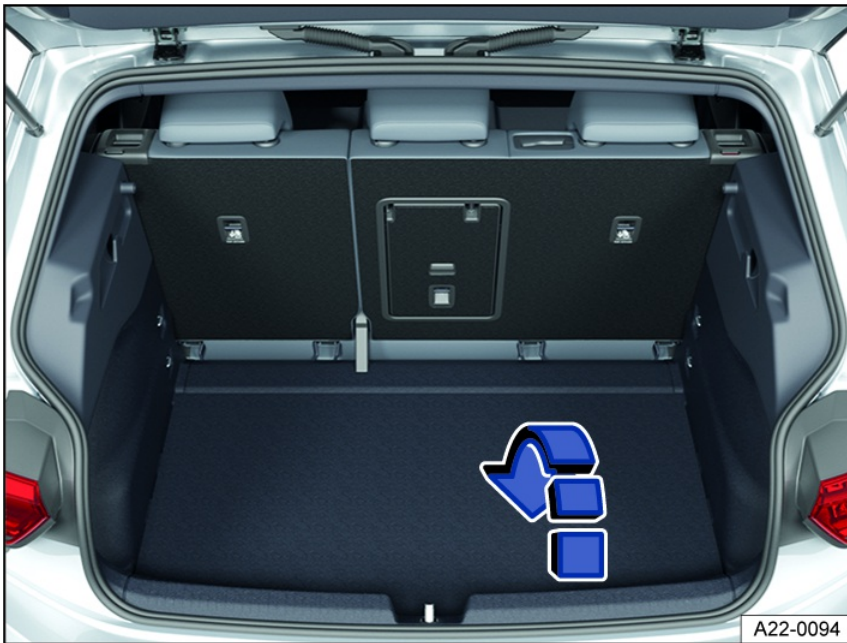

Fig. 116 In the luggage compartment: Luggage compartment floor (general example).

The rear part of the luggage compartment floor can be folded forwards. Underneath, there is a storage compartment, e.g. for the tool box.

Opening the luggage compartment floor

1. Grasp the recessed grip in the luggage compartment floor and lift up the rear part of the luggage compartment floor in the direction of the arrow *fig. 116*.

Closing the luggage compartment floor

1. Fold the luggage compartment floor downward in the opposite direction to the arrow.

NOTICE

Improper use may damage the luggage compartment floor or the luggage compartment trim.

- When closing the luggage compartment floor, always carefully guide it downward, and do not drop it.
- Always distribute loads as evenly as possible across the entire luggage compartment floor to avoid concentrating the load in a single place.

Second luggage compartment floor – functions

Depending on the vehicle equipment, the vehicle may have a height-adjustable second luggage compartment floor.

Opening the second luggage compartment floor



Fig. 117 In the luggage compartment: Opening the second luggage compartment floor.

1. Hold the handle *fig. 117* and fold the rear part of the luggage compartment floor forward in the direction of the arrow.

If the luggage compartment floor is in the bottom position, the rear part will come into contact with the sides of the luggage compartment when it is opened and mu

be pushed through some resistance.

Closing the second luggage compartment floor

1. Fold back the luggage compartment floor and carefully lay it down.

Adjusting the height of the second luggage compartment floor

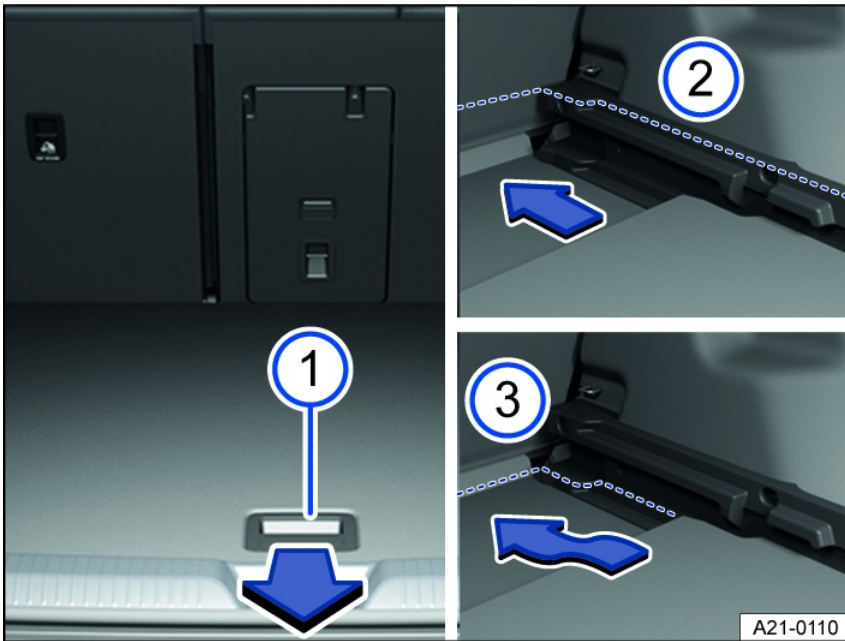

Fig. 118 In the luggage compartment: Adjusting the height of the second luggage compartment floor.

- ① Recessed grip on the luggage compartment floor.
- ② Upper guides on the luggage compartment side.
- ③ Lower guides on the luggage compartment side.

The second luggage compartment floor can be placed in the top and bottom position:

1. Lift the luggage compartment floor using the handle *fig. 118* and pull it backward in the direction of the arrow and out of the guides on the sides of the luggage compartment.
2. Insert the luggage compartment floor into the guides at the desired height *fig. 118* or ③ and push it forward as far as it will go.

⚠ NOTICE

Improper use may damage the second luggage compartment floor or the luggage compartment trim.

- When closing the second luggage compartment floor, always carefully guide it downward, and do not drop it.
- Always distribute loads (max. 50 kg (110 lbs)) as evenly as possible across the luggage compartment floor to avoid concentrating the load in a single place.
- Only transport heavy loads if the luggage compartment floor is in the lower position.

 Volkswagen recommends tying down objects to the tie-downs using fixation belts or tensioning straps.

Luggage compartment features

Tie-downs

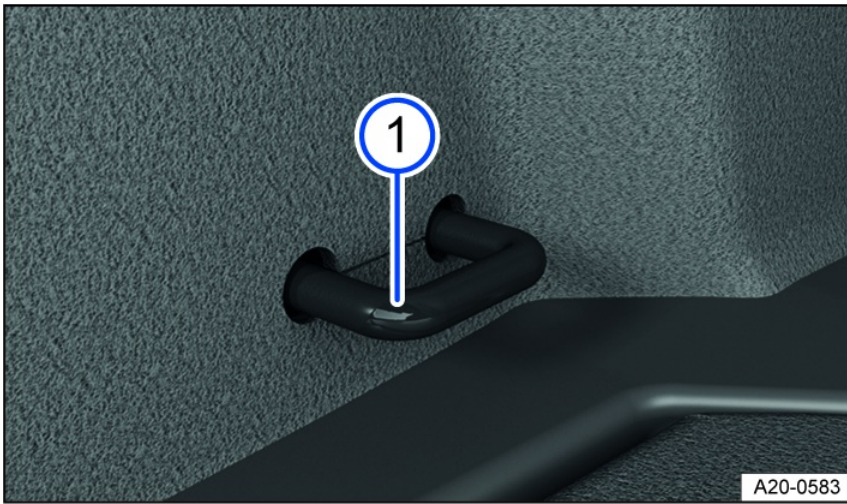

Fig. 119 In the luggage compartment: Tie-down (general example).

① Tie-down.

Tie-downs are located in the luggage compartment to secure loose objects and luggage with the help of lines, fixation belts or securing straps *fig. 119*.

⚠ WARNING

Unsuitable or damaged tie-down straps or tensioning straps could break during braking maneuvers or an accident. This could result in objects being thrown through the vehicle interior and causing serious or fatal injuries.

- Use only suitable and undamaged tie-downs, fixing and tensioning straps.
- Secure cords, fixation belts and tensioning straps diagonally and tightly across the items placed on the luggage compartment floor, and fasten the cords, fixation belts and tensioning straps securely to the tie-downs.
- Make sure that the upper edge of the load is above the tie-downs, especially on flat objects.
- Follow the signs about storing cargo in the luggage compartment, depending on the vehicle equipment.
- Never secure a child restraint to the tie-downs.

⚠ WARNING

Elastic tensioning straps must be stretched for securing to the tie-downs and are therefore under tension. If elastic tensioning straps slip off and spring back toward your body, the hooks attached to them may cause serious injuries.

- Protect your eyes and face when securing and releasing the straps.
- Always hold on to the hooks of the luggage net to prevent them springing out of the tie-down when hooking and unhooking them.
- Always secure elastic tensioning straps to the tie-downs in the front part of the luggage compartment first. Then pull them to the loading edge. Secure the elastic tensioning straps to the tie-downs so that they will spring away from your body if they come off.

 Suitable straps and cargo securing systems are available from an authorized Volkswagen dealer or authorized Volkswagen Service Facility. Volkswagen recommends contacting an authorized Volkswagen dealer or authorized Volkswagen Service Facility.

Luggage net

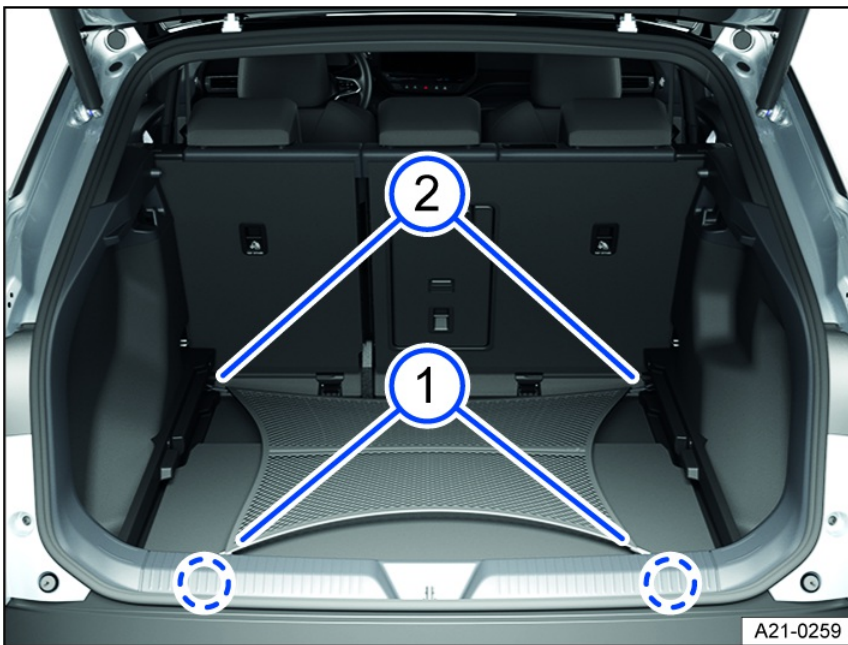

Fig. 120 In the luggage compartment: Level hanging luggage net (general example).

- ① Rear tie-downs.
- ② Front tie-downs.

The luggage net can help to prevent light objects from sliding around in the luggage compartment. The luggage net contains a pocket with a hook-and-loop fastener for storing small objects.

Attaching the luggage net in a flat position on the luggage compartment floor

1. Attach the luggage net hooks to the tie-downs *fig. 120* ② ⇒ ⚠.

The zipper on the luggage net must face upward.

2. Attach the hooks on the other end of the luggage net to the tie-downs under the loading edge *fig. 120* ①.

You may need to fold out the tie-downs to use them ⇒ *Tie-downs*.

Removing the luggage net

The luggage net is under tension when it is installed ⇒ ⚠.

1. Unhook the hooks of the luggage net.
2. Store the luggage net in the luggage compartment.

⚠ WARNING

An elastic luggage net needs to be stretched for securing to the tie-downs, which means that it is held under tension. If an elastic luggage net slips off and springs back toward your body, the hooks attached to them may cause serious injuries.

- Protect your eyes and face when securing and releasing the straps.
- Always hold on to the hooks of the luggage net to prevent them springing out of the tie-down when hooking and unhooking them.
- Always secure the hooks of the luggage net in the order described so that, if the luggage net does snap off, it does so away from your body.

⚠ WARNING

If used improperly, the luggage net hooks could break during a braking maneuver or in the event of an accident. This could result in objects being thrown through the vehicle interior and causing serious or fatal injuries.

- Only use the luggage net hooks to secure a luggage net.
- Never secure a child restraint to the luggage net hooks.

Shopping bag hooks

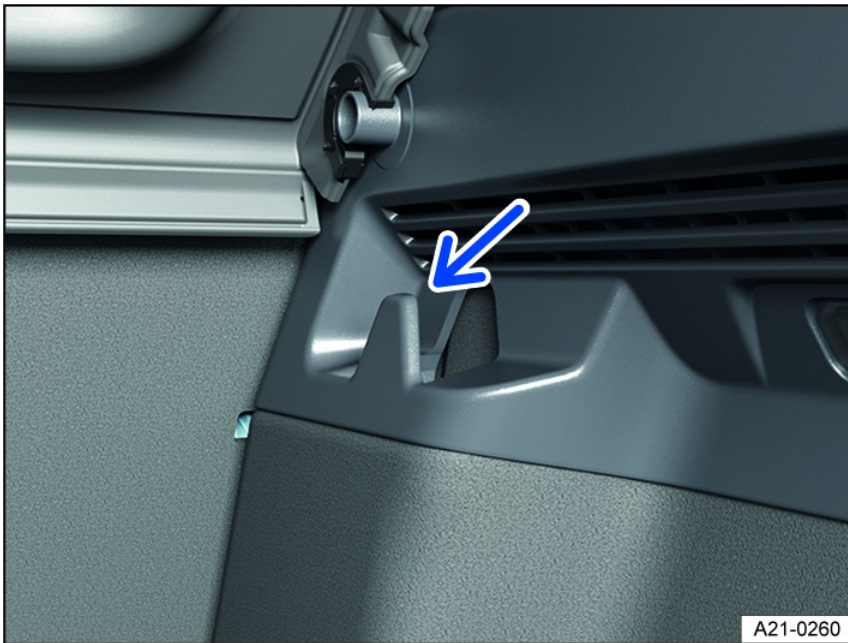

Fig. 121 Shopping bag hooks on the left and right of the luggage compartment.

You may have shopping bag hooks in your luggage compartment for hanging light shopping bags.

⚠ WARNING

Luggage or other items tied to the shopping-bag hooks may tear off and be thrown into the vehicle interior during a braking maneuver or accident. This may cause you to lose control of the vehicle and result in serious or fatal injuries.

- Never use the shopping bag hooks to tie down pieces of luggage or objects.
- Only hang lightweight items, up to a maximum of 2.5 kg (approximately 5.5 lbs), from the shopping bag hooks in the vehicle.

Load-through hatch



Fig. 122 Pass-through in the rear seat backrest.



Fig. 123 Pass-through in the luggage compartment.

Depending on the vehicle equipment, there may be a load-through hatch behind the center armrest in the rear seat backrest for transporting long objects, such as skis, inside the vehicle.

Opening the pass-through from the vehicle interior

1. Fold the center armrest forward ⇒ *Center armrest*.
2. Pull the release lever in the direction of the arrow *fig. 122* and fold the luggage compartment pass-through cover all the way forward ⇒ ⚠.
3. Open the trunk lid.

Opening the pass-through from the luggage compartment

1. Press the release lever down in the direction of the arrow *fig. 123* and fold the cover forward.
2. Insert long objects from the luggage compartment side and slide them forward through the load-through hatch.
3. Secure objects with a seat belt if necessary.
4. Close the trunk lid.

Closing the load-through hatch

1. Fold the flap for load-through hatch backward until it clicks into place.

There may be a red mark on the luggage compartment side. This should not be visible ⇒ ⚠.

2. Close the trunk lid.
3. If necessary, fold the center armrest backward.

⚠ WARNING

Folding and unfolding the load-through hatch in an uncontrolled or careless manner may result in serious injury or death.

- Never fold the luggage compartment pass-through forward or back while driving.
- When folding up the pass-through, make sure that the safety belt does not become trapped or damaged.
- Keep hands, fingers, feet and other body parts away from the pivot range of the pass-through when folding it forward or back.
- Always check that the red mark on the catch indicator is not visible when the pass-through is in the upright position. A red marking indicates that the luggage compartment pass-through is not locked into place.
- If the luggage compartment pass-through is folded down or is not securely engaged, no passengers, especially children, are to be transported on this seat.

Trailer towing

📖 Introduction

If equipped correctly, the vehicle can be used to tow a trailer.

Driving a trailer not only increases the vehicle load, but requires more concentration from the driver.

The increased towing weight affects vehicle wear, consumption, and vehicle performance and may shorten the service intervals.

If the vehicle is driving with a heavy load, functions such as the air conditioner power may be reduced or deactivated to prevent the vehicle from becoming stranded in traffic.

The load that a vehicle is able to pull decreases under the following conditions:

- Driving on slopes.
- Driving at high altitudes.
- Driving in high outside temperatures.
- Driving with a fully loaded vehicle, e.g. with passengers and luggage.
- Driving at high speeds.

Trailer with function check for the lighting

No trailer with tail lights and brake lights that require a function check for the tail light or brake light in order to be approved may be operated on this vehicle. Please consult the trailer manufacturer to find out what approval applies to your trailer.

Unused ball mount

Swivel the ball mount or remove it if there is no trailer, bicycle rack or similar attached to the ball mount. This is especially applicable if the vehicle's license plate or lighting is obscured by the unused ball mount. Note the country-specific regulations for using a ball mount ⇒ .

Special conditions

Before driving with a trailer, please note that the functions of the assistance and parking systems may be limited.

DANGER

Transporting persons in a trailer can cause life-threatening injuries and may be against the law.

- Never transport anyone in a trailer.

WARNING

Using the trailer hitch incorrectly can result in loss of control of the vehicle, accidents and serious or fatal injuries.

- Install and use the trailer in accordance with the instructions provided by the corresponding manufacturer.
- Only use the ball mount if it is undamaged and secured correctly.
- Do not modify or repair the ball mount.

WARNING

If the ball mount is swiveled out, there is an increased risk of accidents and serious injuries for pedestrians and cyclists near parked vehicles and if rear collisions occur.

- Swivel the ball mount in or remove it when it is not in use.

WARNING

The vehicle is not designed for 'weight-distributing' or 'load-equalizing' trailer hitches. The trailer hitch could malfunction and the trailer could disconnect from the vehicle. This can cause accidents and serious injuries.

- Never install weight-distributing or load-equalizing trailer hitches.

WARNING

Driving with a trailer and transporting heavy or large objects can change the vehicle handling performance, increase the braking distance, and cause accidents and serious or fatal injuries.



- Always secure cargo correctly with suitable and undamaged cords, fixation belts or tensioning straps.
- Note that trailers with a high center of gravity may tip sooner than trailers with a low center of gravity.
- Always adapt your speed and driving style to the visibility, weather, road and traffic conditions.
- Always drive carefully and try to anticipate what may be ahead.
- Accelerate with extra care and caution.
- Avoid abrupt and sudden driving and braking maneuvers.
- Do not drive faster than 80 km/h (50 mph), or 100 km/h (60 mph) if absolutely necessary, when towing a trailer. This also applies in countries where

higher speeds are permitted.

- Reduce the vehicle speed, especially when driving on slopes or downhill.
- Adhere to the applicable local maximum speed limit, which may be lower for vehicles towing a trailer than it is for vehicles that are not towing a trailer.
- Overtake especially carefully and reduce vehicle speed as soon as you detect the slightest swaying movement in the trailer.
- Never try to straighten out a swaying vehicle and trailer by accelerating.
- Look out for potential messages and warning and indicator lights turning on in the Volkswagen Digital Cockpit because of the increased load for the towing vehicle.

 **Some retrofitted trailer hitches cover the mount for the towing eye. If this is the case, it will not be possible to use the towing eye to tow other vehicles. Because of this, you should always keep the ball mount from a retrofitted trailer hitch inside the vehicle when it is removed.**

Hitching a trailer

 Please read the introductory information and heed the Warnings and Notice ⇒  and  *Introduction*.

Trailer socket

If the trailer has a 7-pin connector, a suitable adapter must be used.

1. Lift the socket cap and insert the plug.
2. Rotate the plug clockwise by a quarter of a rotation until it fully engages into the socket.
3. Release the cap to lock the plug in place.
4. Check that the entire lighting system is working properly before starting the journey.

If you are not sure how to connect the trailer with the towing vehicle's electrical system correctly, consult an authorized Volkswagen dealer or authorized Volkswagen Service Facility. Volkswagen recommends contacting an authorized Volkswagen dealer or authorized Volkswagen Service Facility.

Safety chains

Always make sure that the safety chains are correctly secured on the vehicle. The safety chains require sufficient play and can sag, but should not touch the ground.

WARNING

Improperly or incorrectly connected electrical wires can electrify the trailer and lead to malfunctions in the entire vehicle electronics system as well as accidents and serious or fatal injuries.

- Have all work on the electrical system performed only by an authorized Volkswagen dealer or authorized Volkswagen Service Facility. Volkswagen recommends contacting an authorized Volkswagen dealer or authorized Volkswagen Service Facility.
- Never connect the electrical system on a trailer to the electrical connectors for the taillights or other power sources on the towing vehicle.

WARNING

Contact between the pins on the trailer socket can cause short circuits, overloading of the electrical system, or malfunction of the lighting system, which can result in accidents and serious or fatal injuries.

- Never connect the pins in the trailer socket to one another.
- Have bent pins repaired only by an authorized Volkswagen dealer or authorized Volkswagen Service Facility. Volkswagen recommends contacting an authorized Volkswagen dealer or authorized Volkswagen Service Facility.

NOTICE

If a trailer hitched to the vehicle is resting on a supporting wheel or on the trailer support, the vehicle may lift and lower due to changes in the load or tire damage. This would put great stress on the trailer hitch and the trailer. This can cause damage to the vehicle and trailer.

- Note that a trailer that is resting on a supporting wheel or on the trailer support should not remain hitched to the vehicle.

 **If the engine is stopped and accessories on the trailer are on while there is an electrical connection through the trailer socket, then the 12 V vehicle battery will drain.**

 **The electrical connection to the trailer will be automatically disconnected if the charge level of the 12 V vehicle battery becomes too low.**

Loading a trailer

 Please read the introductory information and heed the Warnings and Notice ⇒  and  *Introduction*.

General information

Always ensure that the vehicle and trailer are well balanced. Do not load the trailer unevenly by putting more weight at either the front or the back. Always store heavy objects as close as possible to or above the axle. Always secure the load on the trailer properly ⇒ .

Trailer load and tongue weight

The trailer load is the weight that the vehicle can tow.

The trailer tongue weight rating is the load that presses down vertically from above onto the ball mount of the trailer hitch.

Volkswagen recommends always using the maximum permissible trailer tongue weight rating ⇒ [Technical data](#). Tongue weight that is too low affects the trailer's handling. The maximum permissible trailer tongue weight rating of the trailer drawbar on the trailer hitch ball head must not be exceeded ⇒ .

The actual trailer tongue weight rating increases the weight on the rear axle and reduces the possible load in the vehicle.

In some countries, under certain conditions, a higher trailer tongue weight rating can be used. Follow the local specifications and regulations.

Towing weight

The towing weight consists of the actual weights of the loaded towing vehicle and the loaded trailer.

In some countries, trailers are divided into classes. Volkswagen recommends consulting with an authorized Volkswagen dealer or authorized Volkswagen Service Facility about suitable trailers. Volkswagen recommends contacting an authorized Volkswagen dealer or authorized Volkswagen Service Facility.

Tire pressure

The tire pressure for the tires on the trailer is based on the recommendation of the trailer manufacturer.

When towing a trailer, inflate the tires on the towing vehicle to the maximum permissible tire pressure ⇒ [Checking the tire pressure](#).

WARNING

Sliding loads can considerably impair driving stability and trailer safety and increase the risk of accidents and serious injuries or death.

- Always load trailers correctly.
- Always secure cargo with suitable and undamaged cords or tensioning straps.

WARNING

If the gross axle weight rating, trailer tongue weight rating, gross vehicle weight rating or towing weight of the vehicle and the trailer are exceeded, accidents and serious injuries or death can result.

- Never exceed the specified values ⇒ [Technical data](#).
- Never exceed the maximum Gross Axle Weight Rating on the front or rear axle.
- Never exceed the maximum Gross Vehicle Weight Rating for the front and rear weight of the vehicle.

Driving with a trailer

 Please read the introductory information and heed the Warnings and Notice ⇒  and  [Introduction](#).

Headlight adjustment

When a trailer is attached, the front part of the vehicle may be lifted, and the dipped beam headlights may dazzle other road users. Lower the beam corresponding using the headlight range control. Vehicles with dynamic headlight range control adjust automatically and do not need to be manually adjusted.

Characteristics when driving with a trailer

- When driving with a trailer with an overrun brake, first brake gently then rapidly. This avoids braking jolts due to the trailer wheels locking.
- The braking distance increases due to the gross combination weight (of the trailer and vehicle).
- Select a higher energy recuperation level when going downhill. This utilizes the braking effect of the electric drivetrain and reduces the load on the brakes. Otherwise the brake system may overheat and possibly fail.
- The vehicle's center of gravity, and thereby also its driving characteristics, are changed by the towing weight and the increased total weight of the vehicle and trailer.
- An empty towing vehicle and loaded trailer create a very unfavorable weight distribution. Drive very carefully and slowly with this combination.



Driving on hills with a trailer

Depending on the angle of the hill and the total weight of the trailer, a parked trailer may roll back slightly when you start driving.

When towing a trailer, start on a hill as follows:

1. Press and hold the brake pedal.
2. Engage gear **D/B**.

The electronic parking brake is disengaged

3. Press and hold the  button to hold the vehicle and trailer with the electronic parking brake.
4. Release the brake pedal.
5. Start driving slowly.
6. Only release the  button once the electric drivetrain has created enough drive power to start driving.

WARNING

Towing a trailer incorrectly can result in loss of control of the vehicle and cause serious or fatal injuries.

- Bear in mind that the driving characteristics change when driving with a trailer and transporting heavy or large objects.
- Always adapt your speed and driving style to the visibility, weather, road and traffic conditions.
- Always drive carefully and try to anticipate what may be ahead.
- Overtake with particular care and reduce vehicle speed as soon as you detect the slightest swaying movement in the trailer.
- Accelerate with extra care and caution.
- Brake earlier than usual as the braking distance may be longer.
- Avoid abrupt and sudden driving and braking maneuvers.
- Reduce the vehicle speed, especially when driving downhill.
- Never try to "straighten out" a swaying vehicle and trailer by accelerating.
- Adhere to the applicable local maximum speed limit, which may be lower for vehicles towing a trailer than it is for vehicles that are not towing a trailer.

WARNING

A poor rear view when pulling a trailer may result in accidents and serious or fatal injuries.

- Ensure sufficient visibility behind you.
- Install additional rearview mirrors to ensure you have a clear rear view.

Trailer hitch

Ball mount holder

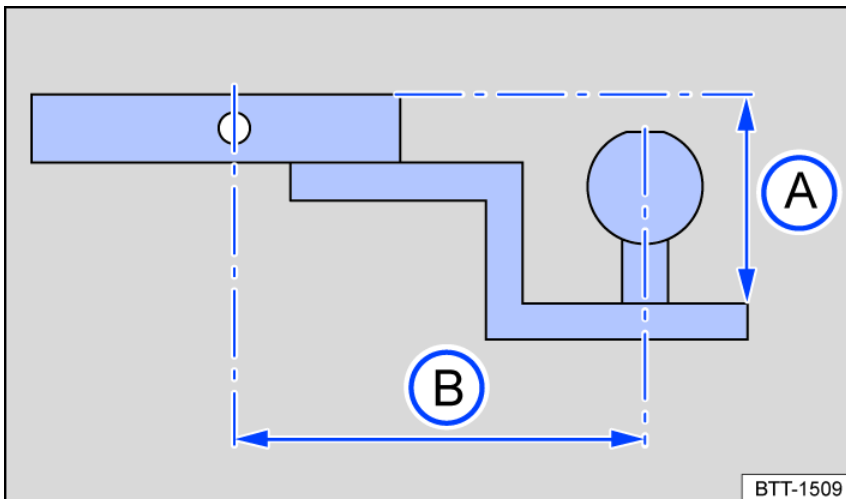



Fig. 124 Dimensions of the ball mount holder and receptacle.

-  Suspended height of the ball mount.
-  Distance between socket pin and ball mount.

To pull a trailer you must have installed the necessary cabling, including a socket, and the corresponding trailer hitch. Since pulling a trailer represents a heavy strain for the vehicle towing it, connecting the trailer to the towing vehicle and correct dimensions for the receptacle and the ball mount holder are extremely important in order for the towing vehicle to cope with the strain to be placed on it.

The mount requires a special shape and size of ball mount holder and ball mount. This affects both the suspended height of the ball coupling [fig. 124 !\[\]\(f60b7a900783ac3fd531bfd9c111be6d_img.jpg\)](#) and the distance between the socket pin and the ball coupling [fig. 124 !\[\]\(fe5cf1978663f480c504f8fc2019fe62_img.jpg\)](#).

These dimensions determine the distribution of strain on the receptacle and the connections to the vehicle during towing. When purchasing a ball mount holder and a ball mount, always ensure that these will cope with the requirements.

Dimensions of the ball mount holder

- The drop heights *fig. 124* **A** from the upper edge of the ball mount to the upper edge of the neck may be no more than 63.5 mm (2 1/2 inches) in the "DROP" position and not more than 47.625 mm (1 7/8 inches) in the "RISE" position.
- The distance between the socket pin and the ball mount *fig. 124* **B** must not exceed 177.8 mm (7 inches) from the middle of the ball mount to the middle of the eye of the pin.
- The diameter of the ball mount may be either 47.625 mm (1 7/8 inches) or 50.8 mm (2 inches).

Ball mounts and holders which do not meet these specifications could damage your car or could fail completely ⇒ .

Securing cables

In some countries, unbraked and braked trailers must be secured by means of securing or breakaway cables.

Follow the country-specific regulations for using a securing cable.

1. Secure the securing or breakaway cable to the provided ball mount eyelet.
2. Guide the cable through the eyelet and hook it in the karabiner ⇒ .

WARNING

Incorrect mounting or the use of an unsuitable trailer hitch can lead to the trailer becoming detached from the towing vehicle during the journey, potentially causing serious accidents and serious or fatal injuries.

- Only have work on your trailer hitch or the retrofitting of a trailer hitch carried out by an authorized Volkswagen dealer or authorized Volkswagen service facility. Volkswagen recommends contacting an authorized Volkswagen dealer or authorized Volkswagen Service Facility.

WARNING

An improperly secured trailer can cause accidents and serious or fatal injuries.

- Never drape the securing or breakaway cable of the trailer loosely over the ball mount.

CAUTION

A fitted but unused ball mount holder can increase the risk of injuries in the event of a rear-end collision.

- Always remove the ball mount holder when it is not being used.

NOTICE

Fitting an unsuitable ball mount can cause vehicle damage and invalidation of the operating license.

- Use the ball mount supplied by the factory or a ball mount approved for your vehicle model and its model year. Volkswagen recommends the use of Volkswagen original parts or Volkswagen original accessories, which you can acquire from an authorized Volkswagen dealer or authorized Volkswagen Service Facility.

NOTICE

The vehicle was not designed to tow trailers requiring larger ball mounts than those specified. The use of an unsuitable trailer hitch can cause vehicle damage.

- Never use ball mounts with a diameter that exceeds 50.8 mm (2 inches).
- Never use an adapter in order to use a larger ball mount.
- If necessary, you may use an adapter to enable you to mount a bicycle carrier or similar. Always observe the weight specifications when doing so.
- Make sure that the taillights are not obscured by the use of a bicycle rack or similar equipment.

²⁾ This data was not available at the time of printing.

Retrofitting a trailer hitch

Volkswagen recommends having a trailer hitch retrofitted by an authorized Volkswagen dealer or authorized Volkswagen Service Facility. For example, modifications to the cooling system or the installation of heat shields may be necessary. Volkswagen recommends contacting an authorized Volkswagen dealer or authorized Volkswagen Service Facility.

Mount the trailer hitch in accordance with the instructions supplied.

A retrofitted, non-removable trailer hitch must not cover the label or the lighting system on the rear of the vehicle. Note the country-specific regulations for using a ball mount ⇒ .

⚠ WARNING

Improperly or incorrectly connected electrical wires can lead to malfunctions in the entire vehicle electronics system as well as accidents and serious or fatal injuries.

- Never connect the electrical system on a trailer directly to the electrical connectors for the taillights or other unsuitable power sources.
- Only use suitable connectors to connect the trailer.
- If retrofitting the vehicle with a trailer hitch, have the work performed by an authorized Volkswagen dealer or authorized Volkswagen Service Facility. Volkswagen recommends contacting an authorized Volkswagen dealer or authorized Volkswagen Service Facility.

⚠ WARNING

Incorrect mounting or the use of an unsuitable trailer hitch can lead to the trailer becoming detached from the towing vehicle during the journey, potentially causing serious accidents and serious or fatal injuries.

- Only have work on your trailer hitch or the retrofitting of a trailer hitch carried out by an authorized Volkswagen dealer or authorized Volkswagen service facility. Volkswagen recommends contacting an authorized Volkswagen dealer or authorized Volkswagen Service Facility.

 Only use trailer hitches that are provided for the vehicle model, model year and vehicle equipment by the corresponding manufacturer. Volkswagen recommends the use of Volkswagen original parts or Volkswagen original accessories, which you can acquire from an authorized Volkswagen dealer or authorized Volkswagen Service Facility.

Roof rack

Introduction

Depending on the model, the vehicle may be designed to have a roof rack installed.

Bulky objects can be transported on the vehicle roof using the roof rack.

If you are not sure if your vehicle is designed to have a roof rack installed, check with an authorized Volkswagen dealer or authorized Volkswagen Service Facility. Volkswagen recommends contacting an authorized Volkswagen dealer or authorized Volkswagen Service Facility.

Only use roof racks that are approved by Volkswagen for use with your vehicle.

Do not use or retrofit a roof rack if this is not approved for your vehicle.

⚠ WARNING

When transporting large, heavy, long, or flat loads on the roof rack, the vehicle's driving characteristics and aerodynamics change because of the different center of gravity and increased wind resistance. This may cause accidents and serious or fatal injuries.

- Always secure cargo correctly with suitable and undamaged cords, fixation belts or tensioning straps.
- Avoid abrupt and sudden driving and braking maneuvers.
- Always adapt your speed and driving style to the visibility, weather, road and traffic conditions.

⚠ WARNING

If the use of a roof rack is not approved for your vehicle or a roof rack that is incompatible with the vehicle is fitted, it may detach and fall from the roof of the vehicle while you are driving. This may cause accidents and serious or fatal injuries.

- Only use roof racks that are approved by Volkswagen for the vehicle.
- Do not fit roof racks if they are not approved for your vehicle.

ⓘ NOTICE

Installing any type of roof rack onto a vehicle that is not approved for use of a roof rack can cause serious damage.

- Do not fit roof racks if they are not approved for your vehicle.

 Driving with a roof rack fitted increases the air resistance of the vehicle and thus also the energy consumption of the electric drivetrain. This reduces the potential vehicle range significantly. This applies to all roof racks and any objects transported on them, such as bicycles and skis.

Mounting a roof rack

 Please read the introductory information and heed the Warnings and Notice  and  Introduction.

For safety reasons, special roof racks are needed to transport luggage, bicycles, surfboards, skis and boats safely.

Only use roof racks that are provided for the vehicle model, model year and vehicle equipment by the corresponding manufacturer.

Volkswagen recommends the use of Volkswagen original parts or Volkswagen original accessories, which you can acquire from an authorized Volkswagen dealer or authorized Volkswagen Service Facility.

Mounting a roof rack on the roof rail

Mount the roof rack in accordance with the instructions supplied.

After the roof rack has been mounted, the rack base can now be secured to it ⇒ .

Remove the roof rack in the following scenarios

- If the roof rack is no longer needed.
- Before driving through an automatic car wash
- If the height of the vehicle exceeds the maximum height limit, for example in a garage

NOTICE

The height of the vehicle changes when a roof rack is installed and when there is cargo secured on it. The vehicle may be badly damaged if you drive into entrances with low heights, e.g. underpasses and garages.

- Compare the height of the vehicle with the clearance height.

NOTICE

If parts on the roof of your particular vehicle (depending on the vehicle equipment), e.g. the roof antenna, and the trunk lid's range of movement are impaired by the roof rack and the luggage, the vehicle may be damaged.

- Ensure that the roof rack is positioned correctly on the roof and that it will not affect any components of the vehicle.



WARNING

Securing the roof rack and base incorrectly or using them incorrectly may cause the luggage or the entire assembly to come loose from the vehicle roof. This can result in accidents and serious injury or death.

- Always mount the roof rack and base correctly in accordance with the manufacturer's instructions.
- Secure the roof rack only at the locations intended for this.
- Always mount special rack assemblies for bicycles, skis, surfboards, etc. correctly and in accordance with the manufacturer's installation instructions.
- Only use the roof rack and base if they are undamaged and secured correctly.
- Check the roof rack mounts before starting a journey and, if necessary, retighten them after a short distance.
- On long trips, check the threaded connections and fasteners each time you take a break.
- Do not make any modifications or repairs to the roof rack or base.

 A fitted roof rack increases air resistance and therefore may reduce the vehicle's range.

Loading the roof rack

 Please read the introductory information and heed the Warnings and Notice ⇒  and  Introduction.

Maximum permissible roof weight

The maximum permissible roof load is 75 kg (165 lbs).

The roof load consists of the weight of the roof rack and the items carried on the roof rack ⇒ .

Always check the weight of the roof rack and the items that will be transported on it. Weigh the items if necessary.

When using a roof rack with a low load limit, do not load the rack with the maximum permissible roof load. In this case, only load the roof rack to the weight limit list in the installation guide.

Distributing the load

Distribute the load evenly and secure it correctly ⇒ .

Checking that everything is secure

Once you have fitted the roof rack, drive a short distance and then check all the fasteners. Keep checking them regularly ⇒ .

⚠ WARNING

Accidents, vehicle damage and serious or fatal injuries can result if the maximum permissible roof load is exceeded.

- Never exceed the specified roof load, the Gross Axle Weight Rating, and the Gross Vehicle Weight Rating of the vehicle.
- Do not exceed the load limit of the roof rack, even if the roof load is below the limit.

⚠ WARNING

If loose and incorrectly secured luggage falls off the roof rack, accidents and serious or fatal injuries may occur.

- Use only suitable and undamaged tie-downs, fixing and tensioning straps.

ⓘ NOTICE

If the trunk lid hits the roof load, the vehicle may be damaged.

- Make sure the trunk lid does not run into the roof load when opening the lid.

High-voltage battery

Safety instructions

Introduction

DANGER

The components of the high-voltage system are under high electrical voltage. Contact with live components of the high-voltage system causes burns, serious injuries or fatal electric shock.

- Always assume that the high-voltage battery is fully charged and that all the high-voltage components are live. This may be the case even if the ignition is switched off.
- Never touch high-voltage components or orange high-voltage cables. Damage to high-voltage components is not always obvious.
- Never remove the orange high-voltage cables and never damage or modify them.
- Never disconnect the high-voltage cable from the high-voltage system.
- Never open or modify the cover of the high-voltage battery and never remove it.
- Never perform repair and maintenance procedures on orange high-voltage cables or high-voltage components. Always have work on the high-voltage system performed by a suitably qualified authorized Volkswagen dealer or authorized Volkswagen Service Facility approved for this work. Volkswagen recommends contacting an authorized Volkswagen dealer or authorized Volkswagen Service Facility.
- Never perform any work in the vicinity of high-voltage components or high-voltage cables using cutting, shaping, or sharp-edged tools or heat sources.

DANGER

Any damage to the vehicle or high-voltage battery may result in the immediate or delayed escape of poisonous gases or liquids. The escaping gases may cause a fire. There is a risk of serious or fatal injuries.

- Do not breathe in gases leaking out of the high-voltage battery.
- Never touch liquids leaking from the high-voltage battery.
- If a fire breaks out, leave the danger zone with all vehicle occupants and contact the fire department.
- Always let the fire service and emergency responders know that your vehicle is equipped with a high-voltage battery.

NOTICE

The high-voltage battery can be damaged by an accident or if the vehicle runs into an obstacle.

- Have your high-voltage battery checked by fully qualified professionals after an accident or if the vehicle runs into an obstacle. Volkswagen recommends contacting an authorized Volkswagen dealer or authorized Volkswagen Service Facility.
- If the high-voltage system has been switched off, secure the vehicle and obtain professional assistance. The vehicle is no longer ready to drive.

Warning signs for the high-voltage system

 Please read the introductory information and heed the Warnings and Notice ⇒  and  Introduction.

Where can warning signs be attached?

- Covers and caps behind which there are high-voltage components.
- All high-voltage components, including the high-voltage battery.
- Under the hood.

Warning signs

The following illustrations may differ slightly from the warning signs on the vehicle.



Fig. 125 Warning sign on the battery charger and other high-voltage components.



Fig. 126 Warning sign in the hood space.

These warning signs indicate a high electrical voltage [fig. 125](#), [fig. 126](#).



Fig. 127 Warning sign on the battery charger.

This warning sign [fig. 127](#) indicates that parts of the high-voltage system can become very hot and must not be touched.

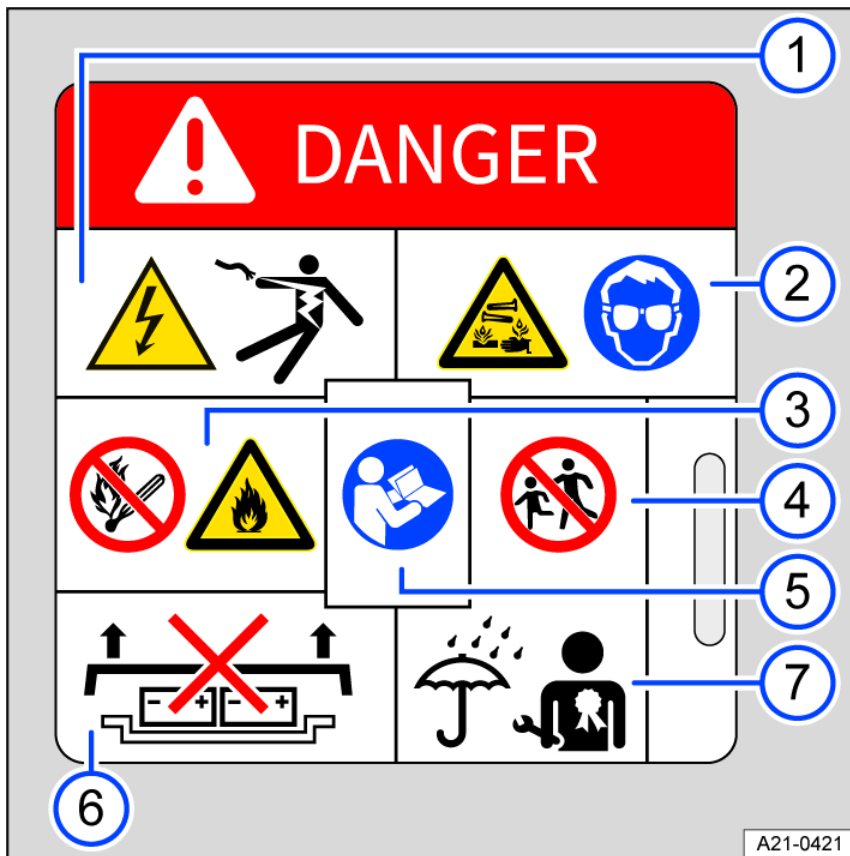

Fig. 128 Warning sign on the high-voltage battery.

- ① Exposure to high voltages can result in serious injury or even death. Never touch the battery terminals with your fingers or with tools, or allow jewelry or other metal items in contact with your body to touch the battery terminals.
- ② The high-voltage battery contains hazardous liquids and solids. Escaping gas can cause serious chemical burns and could blind you. When working on the high-voltage battery, always wear suitable protective eyewear and protective clothing to prevent battery fluid from coming into contact with your skin and eyes. If battery fluid does come into contact with your skin or eyes, run clean water over the affected areas for at least 15 minutes and seek medical attention immediately.
- ③ Under certain circumstances, the high-voltage battery can catch fire. Never expose the high-voltage battery to fire, sparks or naked flames. To prevent damage and fluid leakage, always handle the high-voltage battery with care.
- ④ Keep children away from the high-voltage battery at all times.
- ⑤ Further information and warnings can be found in the Owner's Manual and in the workshop information.
- ⑥ Improper handling of the high-voltage battery can result in serious injury or even death. Never remove the cover from the high-voltage battery and never disassemble the high-voltage battery.
- ⑦ Improper handling of the high-voltage battery can result in serious injury or even death. Have all maintenance procedures on the high-voltage battery performed by fully qualified professionals. Never modify the high-voltage battery. When the high-voltage battery is open, do not allow it to come into contact with water or other liquids. Liquids can cause short-circuiting, electric shock and burns.

Charging the high-voltage battery

Introduction

Requirements

- ✓ Vehicle's drive system is deactivated.
- ✓ Charging cable and charging infrastructure are working correctly and have been checked ⇒ ⚠.

Types of charging

- AC (alternating current) charging at a charging station or wall box ⇒ *Charging*.

It is charged with a high charging power. The maximum achievable charging power results from the charging station used, the charging cable used and the equipment of the battery charger.

- AC (alternating current) charging at a mains socket ⇒ *Charging*.

The household's electrical installation must be checked and must be working correctly ⇒ ⚠. Plenty of charging time should be scheduled in, e.g. overnight.

- DC (Direct Current) Charging at the Charging Station or Wall Box ⇒ *Charging*:

It is charged with a very high charging power. This significantly reduces the charging time. Please read the notes on frequent charging with direct current (DC) ⇒ ⚠.

NOTICE

A very high charging power is used for fast-charging with direct current (DC). Frequent fast-charging can permanently reduce the battery capacity of the high-voltage battery.

- The high-voltage battery should be mainly charged with alternating current (AC) at a charging station or wall box.

 **When charging with alternating current (AC), it is recommended to charge with maximum charging power at a charging station or wall box. This achieves a higher efficiency compared to charging with a mains socket.**

 **Please note the technical information about your vehicle's charging power. For more information contact an authorized Volkswagen dealer or authorized Volkswagen Service Facility.**

WARNING

Failure to comply with the operating and safety instructions or improper use of the high-voltage battery and charging cable could result in a short circuit, electric shock, explosions and fire. There is a risk of damage and serious or fatal injuries.

- Always end the charging process before removing the mains plug to avoid coming into contact with residual power in the charger.
- Pay attention to the safety and operating information for the supplied charging cable.
- In the household, only use a connection that is suitable for electric vehicles and has been installed and tested by qualified professionals.
- Never charge in areas where there is a risk of explosion. Charging cable components can trigger sparks and can ignite flammable or explosive vapors.
- Always protect electrical connections from direct contact with water, damp, and other fluids.
- Do not carry out any other work on or around the vehicle during charging for safety reasons.

WARNING

Driving with a low high-voltage battery charge level can cause the vehicle to become stranded in traffic. Accidents and serious injuries could result.

- Always charge the high-voltage battery before starting a journey.

 **The high-voltage battery can only be charged at charging stations which meet the requirements of the country and abide by at least the following norms:**

- IEC 61851 and IEC 62196 (Europe).
- GB/T 18487 and GB/T 20234 (China) in the 2015 version.
- SAE J1772 (Japan).
- SAE J1772 (USA and Canada).

Handling the high-voltage battery

 Please read the introductory information and heed the Warnings and Notice ⇒  and  Introduction.

Reliability and battery capacity of a high-voltage battery

A lithium-ion battery is generally subject to a physical and chemical aging and wearing process over its service life. Correct handling of the high-voltage battery can significantly contribute to a reliable battery state and a high usable battery capacity and range in the long-term. This makes it all the more important to comply with the following care instructions for the high-voltage battery. If you follow these care instructions, the vehicle can maintain its value for a long time.

Also observe the applicable Volkswagen guarantee and warranty conditions for the high-voltage battery. For more information, contact your authorized Volkswagen dealer or authorized Volkswagen Service Facility.

Charging recommendations

Volkswagen recommends observing the following charging recommendations:

- For everyday use, set the maximum battery charge level to 80% in the Infotainment system ⇒ *Battery charge limits*.
- Charge the high-voltage battery once the battery charge level is below 20%. Ideally avoid the high-voltage battery being fully discharged ⇒ .
- Charge the high-voltage battery to 100% before long journeys. Set a departure time in the Infotainment system ⇒ *Departure Times (time-delayed charging)* : drive off as immediately after charging as possible.
- Avoid regular rapid charging with direct current (DC).

NOTICE

The high-voltage battery must not be manipulated for use as a stationary power source. This may lead to irreversible damage to the high-voltage battery.

- Never make technical modifications to or tamper with the high-voltage battery and high-voltage components.

Battery Care Mode

The maximum battery charge level is automatically limited to 80 % for the next charging process.

1. Tap **HOME** in the Infotainment system.
2. Tap **Charging**.
3. Tap **Setup**.
4. Activate the function.

! Volkswagen recommends using the Battery Care Mode function for everyday use to protect the high-voltage battery.

! If charging at a certain departure time is activated, the function cannot be used.

Periods when the vehicle is unused

- If you intend to leave the vehicle parked for longer periods, park it with a battery charge level between 40% and 70%.
- Ideally avoid high outside temperatures, especially in direct sunlight, when the vehicle is parked for longer periods.
- To improve convenience and performance, use stationary air conditioning when required (depending on the vehicle equipment), especially at temperatures below approx. -15 °C (approx. +5 °F) ⇒ *Operating the stationary air conditioning*.

! NOTICE

If the vehicle is parked for an extended period with a discharged high-voltage battery, the high-voltage battery may not be able to charge or the vehicle might not start. In the long-term, this can lead to irreversible damage to the high-voltage battery.

- Charge the high-voltage battery at regular intervals.

! The high-voltage battery has less power available in very low temperatures. If the battery charge level is also low, the driving power may also be limited for a short time after pulling away.

Charging

! Please read the introductory information and heed the Warnings and Notice ⇒ **!** and **!** Introduction.

The high-voltage battery can be charged with alternating current at the charging station or GFI outlet (AC charging) or with direct current at the rapid charging station (DC charging).

Connecting the charging cable

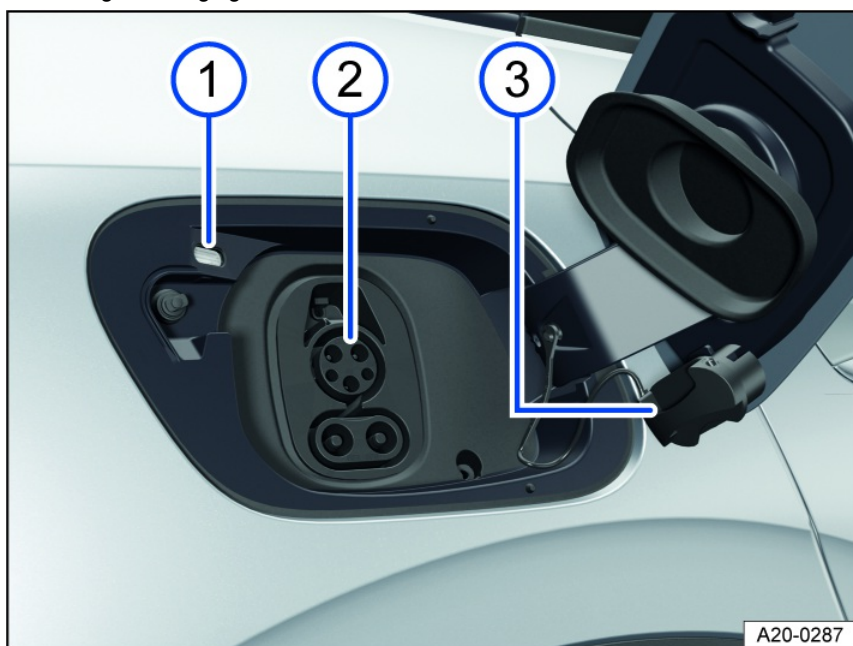

Fig. 129 Behind the rear-right charging socket flap: Charging socket.

- ① Charging process display.
- ② Charging socket with AC connection (top) and DC connection (bottom).

③ Protective cap on the support.

1. Unlock the vehicle.
2. Press gently on the charging socket flap to open it.
3. Remove the charging cable from the charging station or connect to the power supply and fully unwind.

Charging cable for mains sockets: The protective device of the charging cable will carry out a self-test → [Charging cable for mains sockets](#).

4. Insert the charging connector straight into the charging socket and check whether it is fully inserted [fig. 130](#).

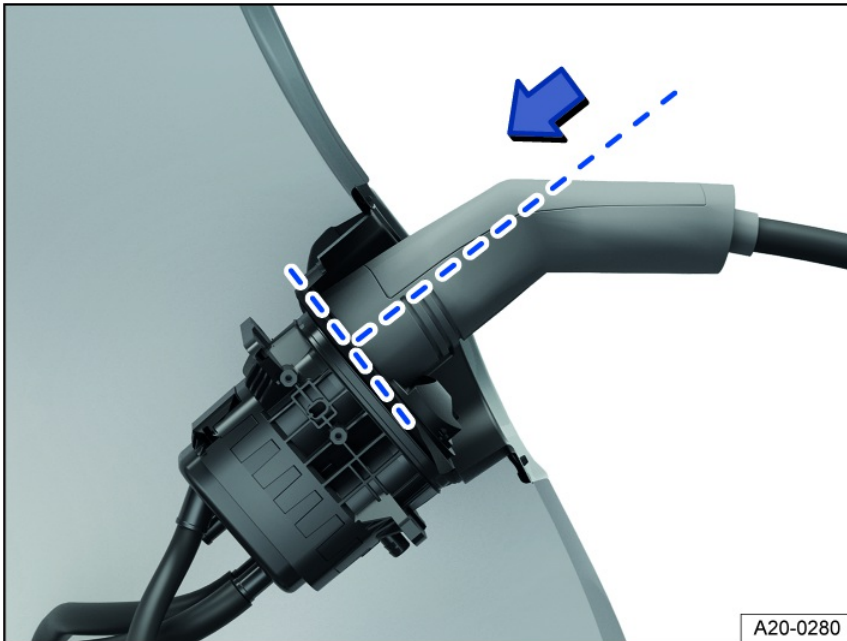

Fig. 130 Fully inserted charging connector (general example).

🔌 When the charging connector is plugged in, the white indicator light in the instrument cluster comes on.

Starting the charging process

1. To achieve the desired range with immediate charging, set the maximum battery charge level on the charging information screen.
2. If necessary, activate the charging station.

The charging process starts immediately or after a delay, depending on the settings for the stored charging location.

🔌 When the high-voltage battery is being charged, the green indicator light in the instrument cluster blinks.

Interrupting the charging process

The charging process can be interrupted at any time.

1. Tap **STOPP** in the Infotainment system.

Or: Press the central locking button when AC charging at the charging station or GFI outlet.

When Automatically release the AC charging cable is selected in the Infotainment system, the charging connector is automatically released.

2. To restart the charging process, tap **START**.
3. Renewed activation may be required at the charging station.

After charging

Once the high-voltage battery has been charged, the charging process indicator on the charging socket turns green.

Charging station or GFI outlet (AC charging):

1. Unlock the vehicle.
2. Press the release button on the charging connector and remove the charging connector.
Or: if Automatically releasing the AC charging cable is selected in the Infotainment system, the charging connector can be unplugged immediately.
3. Disconnect the charging cable from the power supply and replace the protective cap.
4. Close the charging socket flap until it audibly engages.

Rapid charging station (DC charging): The charging connector is automatically unlocked from the charging station after charging and can be disconnected.

Charging for the first time and charging after the vehicle is parked for a long time

If the high-voltage battery is new or has not been charged for a long time, it may not achieve its maximum charge level until several charging processes have been completed. This is a normal feature and is not a vehicle malfunction.

If the vehicle is not used for a long period, the high-voltage battery must be charged within a period of no more than four months → page , *Handling the high-voltage battery*.

 The charging cable for the charging station must not exceed approx. 30 m (approx. 98 ft) in length.

 In extremely low or extremely high temperatures the high-voltage battery charging process may be limited.

Charging process indicator

 Please read the introductory information and heed the Warnings and Notice ⇒  and  Introduction.



Fig. 131 Behind the charging socket flap: charging process indicator.

An LED on the charging socket shows the charging process status *fig. 131* (arrow).

LED displays

A label on the charging socket describes the LED displays *fig. 132*.

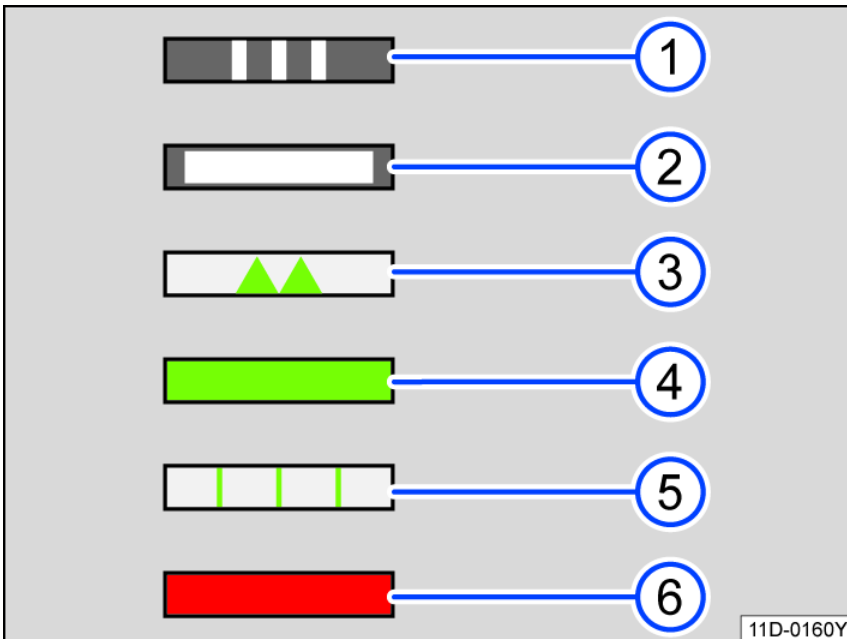



Fig. 132 LED light displays (general example).

- ① Flashing: Charging connector has been detected.
- ② Blinking white: Vehicle is being connected to the charging infrastructure. Preparing for charging.
Light comes on: No active charging function.
- ③ Pulsing green: The high-voltage battery is being charged.
- ④ Green light comes on: Charging process successfully concluded.
Green light comes on alternately with red indicator: Charging with reduced current to prevent becoming stranded in traffic. There is a malfunction, e.g. the charging connector is not fully inserted.

5 Flashing green: A time-delayed charging process has been activated and has not yet begun.

6 Red light comes on: Charging system malfunction.

 **If the charging process indicator continuously displays a malfunction related to the vehicle power supply or charging system, contact an authorized Volkswagen dealer or authorized Volkswagen Service Facility. Volkswagen recommends contacting an authorized Volkswagen dealer or authorized Volkswagen Service Facility.**

Charging socket light

If one of the following conditions applies, the side lighting of the charging socket switches on in darkness:

- The vehicle was unlocked.
- The charging connector was removed from the charging socket.

After locking or unlocking the vehicle, the light turns off automatically after a certain time.

Troubleshooting

 Please read the introductory information and heed the Warnings and Notice ⇒  and  Introduction.

and Risk of fire

The red central warning light  comes on and is shown in the Volkswagen Digital Cockpit display together with a message. A warning tone sounds continuously.

The temperature of the high-voltage battery is too high ⇒ .

1.  **Do not continue driving!** Exit the vehicle and inform the fire department immediately.

If the message disappears, the warning light  is displayed.

DANGER

If there is a risk of fire in high-voltage battery cells, toxic gases may escape or high-voltage components may be live. There is a risk of serious injuries, burns or fatal electric shock.

- Stop the vehicle in a where it is safe to do so as soon as possible.
- Exit the vehicle and stay at a sufficient distance.
- Inform the fire department immediately.

Observe the checklist of what to do in the event of a fire → page , *What to do in the event of an accident or fire*.

The continuous warning tone can only be turned off by suitably qualified professionals. Volkswagen recommends contacting an authorized Volkswagen dealer or authorized Volkswagen Service Facility.

Fault in high-voltage system

The red warning light turns on. A message will appear in the instrument cluster display.

There is a malfunction in the high-voltage system. High-voltage components may be damaged ⇒ .

Charging the high-voltage battery is not possible.

DANGER

In the event of a high-voltage system malfunction, high-voltage components including the high-voltage battery and high-voltage cables may have been damaged and still be live. There is a risk of serious injuries, burns or fatal electric shock.

- Do not touch the high-voltage components or high-voltage cables.

1.  **Do not continue driving!** Park your vehicle outside as soon as it is possible and safe to do so.
2. End drive-ready mode.
3. Contact an authorized Volkswagen dealer or authorized Volkswagen Service Facility immediately for assistance.

High-voltage battery discharged and deep discharge possible

The red warning light turns on. A message will appear in the instrument cluster display.

During a lengthy stationary period, the high-voltage battery can be damaged by deep discharge.

1. Charge the high-voltage battery immediately.

High-voltage battery has been discharged

The yellow indicator light turns on. A message will appear in the instrument cluster display.

1. Charge the high-voltage battery immediately.

High-voltage battery charge level low

The yellow indicator light turns on. A message indicating the remaining range will appear in the instrument cluster display.

The reserve charge level of the high-voltage battery has been reached.

1. Charge the high-voltage battery.

High-voltage system malfunction

The yellow indicator light turns on. A message will appear in the instrument cluster display.

High-voltage components may be malfunctioning.

It is possible to continue driving.

1. Have the high-voltage system checked by suitably qualified professionals. Volkswagen recommends contacting an authorized Volkswagen dealer or authorized Volkswagen Service Facility.

Error when calculating the range

The yellow indicator light turns on. A message will appear in the instrument cluster display.

There is a malfunction in the range calculation.

1. Contact a suitably qualified professional. Volkswagen recommends contacting an authorized Volkswagen dealer or authorized Volkswagen Service Facility.

Emergency charging of the high-voltage battery

The white indicator light comes on. A message will appear in the instrument cluster display. The charging process indicator on the charging socket comes on, alternating between green and red.

A reduced charging current is used for charging and there is a malfunction, e.g. charging connector not correctly plugged in or malfunctioning connection to the charging station.

1. Reconnect the charging cable.
2. If the malfunction persists, contact a suitably qualified professional. Volkswagen recommends contacting an authorized Volkswagen dealer or authorized Volkswagen Service Facility.

Charging Process Not Possible or Canceled

The red charging process indicator on the charging socket comes on.

1. Reconnect the charging cable.

Or: check whether the charging connector is plugged in correctly.

Or: check if there is a malfunction on the charging station.

2. If you cannot resolve the malfunction, contact a suitably qualified professional. Volkswagen recommends contacting an authorized Volkswagen dealer or authorized Volkswagen Service Facility.

The charging connector cannot be removed

1. During AC charging with alternating current, unlock the vehicle via the central locking system. Immediately unplug the charging connector.

Or: to unlock the charging connector prematurely during DC charging, tap **STOPP** on the Infotainment system screen.

2. To prevent the vehicle from being stranded, if necessary, manually unlock the charging connector ⇒ *Emergency release for the charging connector*.

Afterwards, contact a suitably qualified professional. Volkswagen recommends contacting an authorized Volkswagen dealer or authorized Volkswagen Service Facility.

The charging cable protective circuit for the GFI outlet switches off

An error may be recorded by the protective circuit during a self-test if external electrical devices, such as a refrigerator, are used simultaneously in the vehicle.

1. Follow the order specified. Connect the charging cable to the external power supply first and then connect it to the charging socket.

The charging time changes during DC charging

To protect the high-voltage battery from overheating, the charging current is automatically reduced after several DC charge cycles in succession, e.g. during continuous use of the vehicle.

Emergency release for the charging connector

 Please read the introductory information and heed the Warnings and Notice ⇒  and  Introduction.

When can the charging connector be released?

- ✓ The charging connector has been plugged in correctly and is not tilted.

- ✓ Vehicle is unlocked.
- ✓ Charging processes has been stopped or interrupted.
- ✓ If charging with alternating current (AC), select the Automatically releasing the AC charging cable setting.

If the prerequisites are fulfilled and the charging connector still cannot be unplugged, the charging connector can be emergency released ⇒ ⚠.

⚠ DANGER

If the charging connector unexpectedly remains locked, it could be that the vehicle or charging station has a malfunction. Live contacts can be made accessible by manual emergency unlocking. Touching the contact in the charging socket may, in this case, lead to burns, other injuries, or a fatal electric shock.

- Never touch the contacts in the charging socket or the charging connector.

ⓘ Only perform the emergency release on the charging connector if there is a vehicle malfunction.

Electrical emergency release of the charging connector

To avoid manual emergency release in the luggage compartment, try to release the charging connector electrically via the vehicle's central locking.

1. End the charging process via the function key **STOPP** in the Infotainment system or at the charging station.
2. Press the  button on the remote control vehicle key three times in succession.
The turn signal must blink three times.
3. Unplug the charging connector.

Manual emergency release of the charging connector

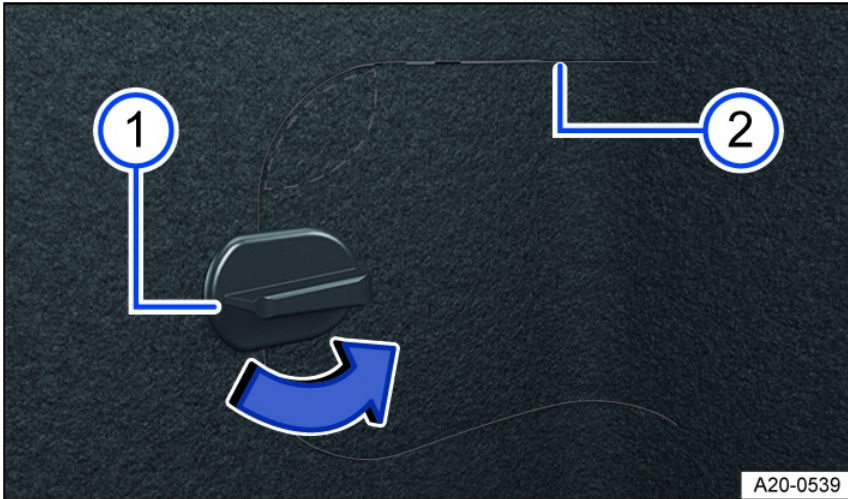

Fig. 133 In the bottom right luggage compartment trim: Flap for emergency release.

- ① Fastener.
- ② Separation points.

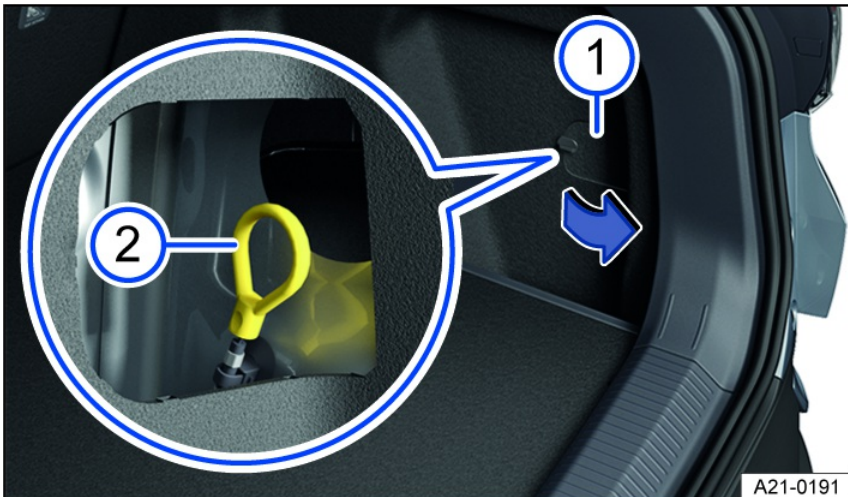

Fig. 134 In the bottom right luggage compartment trim: Emergency release of the charging connector.

- ① Flap with fastener.
- ② Emergency release loop.

On the bottom right-hand side of the luggage compartment, there is a flap with a lock *fig. 134*.

1. Open the luggage compartment.
2. Turn the flap lock by 90° *fig. 133* (blue arrow).
3. Press in the area above the fastener *fig. 133* (area marked).
4. Reach into the opening and pull the flap to release it. If necessary, use a suitable aid at the separation points *fig. 133*.
5. Open the flap.
6. Pull the manual emergency release loop *fig. 134*.

The charging connector can be removed ⇒ ⚠.

7. Close the flap in the luggage compartment trim again with the lock.
8. Have the charging socket checked by suitably qualified professionals. Volkswagen recommends contacting an authorized Volkswagen dealer or authorized Volkswagen Service Facility.

Charging settings

Introduction

In the Infotainment system, it is possible to configure settings for the charging process. Advanced charging settings for AC charging are available in the menu for the saved charging location.

Opening the charging settings

1. Switch the Infotainment system on.
2.  Tap Charging in the main menu.

Or: When the charging connector is inserted into the unlocked vehicle, a screen with charging information is displayed automatically.

3. Open the  Charging menu.

Or: Open the  Charging locations menu and create a charging location.

1. If there is to be time-delayed charging, activate a departure time  ⇒ *Departure Times (time-delayed charging)*.

 **Immediate charging:** Without an activated departure time, the high-voltage battery is immediately charged to the maximum battery charge level ⇒ *Battery charge limits*.

Changing the charging procedure

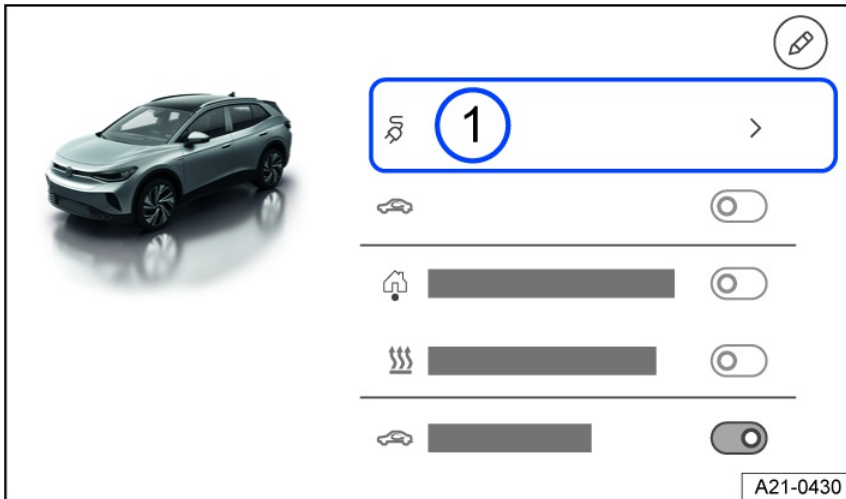



Fig. 135 Infotainment system: exit menu with function key for charging (general example).

- ① Function key for displaying and changing the charging procedure.

You can change the charging procedure in the exit menu or in the  Charging menu. The selection depends on the settings in the created charging location profile and the technical requirements at the location.

1. Tap the function key with the displayed charging procedure *fig. 135* ①.
A list view will open.
2. Select a charging procedure, e.g. immediate charging, charging before a departure time, charging and air conditioning.

Overview of the charging settings

Settings in the Charging menu

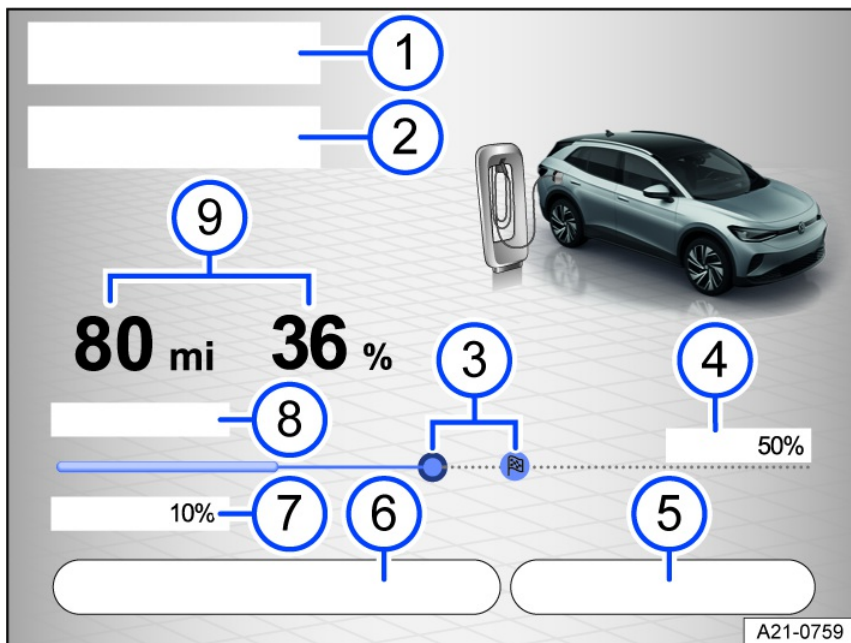

Fig. 136 Infotainment system: function keys and displays for charging (general example).

- ① Current settings or detected charging location.
- ② End of the charging process or scheduled departure time.
Or: stationary air conditioning for departure time (depending on the vehicle equipment).
- ③ Touch control for the maximum battery charge level.
E-route planning navigation symbol: Automatically calculated touch control position.
- ④ Display of the maximum battery charge level.
- ⑤ Stop or restart charging.
- ⑥ Change the charging procedure.
- ⑦ Minimum battery charge level.
- ⑧ Range regained during charging in km/h or km/min and charging power in kW.
- ⑨ Range and battery charge level.

Some of the described displays and settings are also available on the screen with charging information when the charging connector is plugged in.

The displays for the charging power and the duration of the charging process may vary between different charging processes. They depend on the charging infrastructure and the temperature of the high-voltage battery. The charging power can also vary during the charging process.

Settings in the Setup menu

1. Tap (HOME) in the Infotainment system.
2. Tap (Charging) Charging.
3. Tap (Setup) Setup.
 - Battery Care Mode ⇒ *Handling the high-voltage battery.*
 - Automatically releasing the AC charging cable: after the AC charging process has finished, the charging connector is automatically released and can be unplugged immediately. The function depends on the country.
 - Reducing the AC charging current: a lower charging current of 6 A or 8 A is used for charging (depending on the country). This setting is recommended when several large items of electrical equipment are being operated via the same circuit.

Plug & Charge function

The high-voltage battery is charged at a suitable wall box or public charging station as soon as the charging connector is plugged in. Manual activation for cost accounting is not required.

The function depends on the vehicle equipment and the country.

Requirements

- ✓ The charging station supports the Plug & Charge charging function according to ISO 15118.
- ✓ An electricity contract was stored in the vehicle.
- ✓ Plug & Charge was switched on in the Infotainment system.

Switching on and off

1. Tap (Settings) Settings in the Charging main menu of the Infotainment system.

2. Activate Plug & Charge.

The function can be used by the primary user and a guest user. The primary user can switch the function on and off in the vehicle. A guest user can only switch off the function.

Battery charge limits

The battery charge level, and consequently the vehicle range, can be adapted to everyday demands using the battery charge limits in the Infotainment system.

Upper battery charge limit

The maximum battery charge level limits the maximum charge level of the high-voltage battery to between 50 and 100%.

It is not necessary to fully charge the high-voltage battery for standard daily use.

1. Move touch controls in the Infotainment system's charging settings to the preferred value.



The maximum battery charge level can also be adjusted during charging.

Lower battery charge limit

A battery charge level for the high-voltage battery between 0 and 50% can be set.

The vehicle charges immediately once it has been connected to the power and reaches a minimum vehicle range.

Only then are preferred charging times, low tariffs or a departure time for time-delayed charging considered. The function is possible at a saved charging location.

1. Tap  in the Infotainment system.
2. Tap  Charging.
3. Open the  Charging locations menu.
4. Move the touch control in the charging location's profile to the preferred value.

 Volkswagen recommends observing the information on battery care in order to set the battery charge levels correctly ⇒ [Handling the high-voltage battery](#).



Charging locations

Charging locations can be set up in the Infotainment system. The vehicle automatically recognizes a saved charging location and uses the available settings when charging.



Location data

The Infotainment system uses the vehicle's current location data (geocoordinates) when a charging location is created or used.

Creating a charging location

1. Tap  in the Infotainment system.
2. Tap  Charging.
3. Open the  Charging locations menu.
4. Add and name the charging location (five maximum).

Removing a charging location

1. Open the  Charging locations menu.
2. Tap .
3. Tap the  to remove the saved charging location.

Setup

 All of the charging settings that have been saved always apply to the currently recognized charging location. If a Departure Time is activated for the charging location, you can switch to immediate charging in the exit menu of the Infotainment system ⇒ [Exit menu](#).

- Reduce the charging current.
- Automatically releasing the AC charging cable. The function depends on the country.
- Departure time (three maximum) ⇒ [Departure Times \(time-delayed charging\)](#).
- Lower battery charge limit ⇒ [Battery charge limits](#).
- Upper battery charge limit ⇒ [Battery charge limits](#).
- Preferred charging times: individually tailoring charging times can be helpful if there is other electrical equipment in the household or when using off-peak electricity.



- Displays address or geocoordinates.

 Different charging settings can be saved for one charging location.

Departure Times (time-delayed charging)

If you have saved a charging location, the high-voltage battery can be charged at a time of your choice.

Setting a departure time

1. Tap **(HOME)** in the Infotainment system.
2. Tap  Charging.
3. Open the  Charging locations menu.
4. Open the profile of a charging location.
5. Set a departure time (three maximum).
 - Day of the week.
 - Time at which the high-voltage battery should be charged.
 - To be used weekly or as a one-off.

 If time-delayed charging has not been activated in the Infotainment system, the high-voltage battery is charged up to the maximum battery charge level immediately.

Air Conditioning

The vehicle interior is cooled or heated at the departure time by the stationary air conditioning. The function depends on the vehicle equipment.

1. Set the desired temperature in the Stationary air conditioning menu ⇒ *Operating the stationary air conditioning*.
2. Select the function for the charging procedure in the drop-down list.

Activating a departure time

1. Open the profile of a charging location.
2. Activate the departure time by placing a “check mark” in the checkbox.

Displays in the Infotainment system

 Charging at a certain departure time activated.

 Air conditioning at a certain departure time activated.

 Departure time is used regularly.

Charging cable

Introduction

Instructions for the charging cable

The charging cable delivered with the vehicle depends on the scope of supply and the country-specific technical specifications, for example charging plug connectors for mains sockets.

Volkswagen recommends only using the charging cable supplied and observing the following information ⇒  ⇒ .

- Handle with care.
- Roll out or roll in completely.
- Do not fold or bend over sharp edges.
- Do not allow to become trapped or run over.
- Only pull on the charging connectors.
- Children must not use the charging cable.
- Keep animals away.
- Stow away safely and without kinks after use.

DANGER

Using a charging cable that is damaged or has been tampered with can cause an electric shock, resulting in serious injury or death.

- Check the charging connectors and the charging cable for damage, e.g. cracks, before every use.
- Never open the charging cable and its components.

- Never use a charging cable that has been damaged or tampered with.
- In the event of a malfunction, have the charging cable checked by suitably qualified professionals. Volkswagen recommends contacting an authorized Volkswagen dealer or authorized Volkswagen Service Facility.

⚠ WARNING

Charging a high-voltage battery with an unsuitable charging cable can cause short circuits and electric shocks. This could result in damage to the charging cable and serious or fatal injuries.

- Always take note of the information on the charging cable.
- Before traveling abroad, find out about the electrical installations available locally.
- Before traveling abroad, make sure you know which is the correct, country-specific charging cable and what the maximum permitted charging current is.

Stowing the charging cable away



Fig. 137 Under the luggage compartment floor: Storage compartment for the charging cable (general example).

⚠ WARNING

An unsecured or incorrectly secured charging cable can be thrown around the inside of the vehicle during sudden driving and braking maneuvers. This can cause accidents and serious injuries.

- Stow the charging cable in the storage compartment under the luggage compartment floor *fig. 137*.
- **Or:** Stow the charging cable in the charging cable bag provided and hook the charging cable bag to a front tie-down in the luggage compartment.
- If the rear seat backrest has been folded over, stow the charging cable bag in the footwell in front of it.

Instructions for the charging connectors and the protective device of the charging cable

- Do not reach into the contacts of the charging connector.
- Keep away from intense sunlight. The outside temperature must be no higher than 50 °C (122 °F).
- Do not drop.
- Protect against immersion in liquids, e.g. rainwater.
- Replace the protective cap after use.

⚠ WARNING

Incorrectly using or connecting the charging cable for mains sockets can cause a severe malfunction. This could result in damage to the electrical system and the charging cable, as well as fire and serious injury.



- Never connect the charging cable to an extension cable, a cable reel, a socket strip or an adapter, such as a travel adapter or timer.

🔧 As a portable piece of operating equipment, the charging cable may be subject to regular testing obligations. A test adapter is required for this.

🔧 Note the maximum load for the fuse circuit in use. If the charging cable is connected to a mains socket on the same electrical circuit as other consumers, the circuit fuse may be tripped.

♻ Charging cables must be disposed of in an environmentally friendly manner and may not be included with household waste.

Cleaning the charging cable

1. Wipe the surface of the charging cable with a dry or only slightly damp cloth ⇒ , ⇒ .

DANGER

Cleaning a connected charging cable creates a danger of coming into contact with live voltage from the high-voltage system. This can cause an electric shock, resulting in burns and serious injuries or death.



- Only clean the charging cable when it is unplugged.

NOTICE

Improperly cleaning the charging cable could result in damage.

- Only use water and no additional cleaning agents when cleaning the surface.
- Ensure that no water enters the contacts of the charging cable.

Charging cable for mains sockets

 Please read the introductory information and heed the Warnings and Notice ⇒  and  *Introduction*.

A suitable charging cable for mains sockets can be obtained from your authorized Volkswagen dealer or authorized Volkswagen Service Facility.

Do it yourself

Vehicle tool kit

Introduction

When securing the vehicle in the event of a vehicle breakdown, follow the legal regulations applicable in the respective country.

⚠ WARNING

A loose tire mobility set, spare wheel, compact spare wheel or vehicle tool kit can be thrown around the vehicle interior during sudden driving or braking maneuvers or in a collision. This could result in serious or fatal injuries.

- Always make sure the vehicle tool kit, tire mobility set, and spare wheel or compact spare wheel are secured in the luggage compartment.

⚠ WARNING

Working with an unsuitable or damaged vehicle tool kit may result in accidents. This could result in serious or fatal injuries.

- Never work with an unsuitable or damaged vehicle tool kit.
- Seek assistance from an authorized Volkswagen dealer or authorized Volkswagen Service Facility if there is no suitable vehicle tool kit available.

Placement

📖 Please read the introductory information and heed the Warnings and Notice ⇒ ⚠ Introduction.

There are a number of different storage locations for the tool box in the vehicle, such as under the luggage compartment floor or in a side storage compartment of the luggage compartment.

Depending on the equipment variant, the vehicle may contain a loose box with the vehicle tool kit in the luggage compartment. This supplemental vehicle tool kit is designed for a possible winter tire change and does not need to be carried in the vehicle at all times → page , *Stowing luggage and cargo* .

🔧 If used, crank the vehicle jack back down so that it can be securely stowed in the vehicle.

Vehicle tool kit components

📖 Please read the introductory information and heed the Warnings and Notice ⇒ ⚠ Introduction.

The scope of the tool box depends on the country and equipment. The following information describes the full scope of items that may be included.

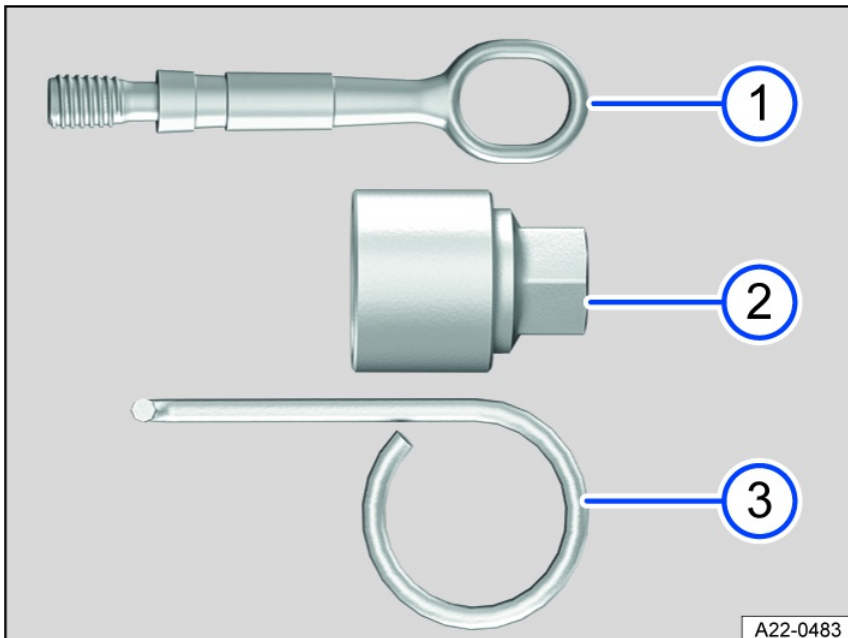

Fig. 138 Vehicle tool kit components (general example).

- ① Towing eye that can be screwed in.
- ② Adapter for the anti-theft wheel bolt. Volkswagen recommends always keeping the adapter for the wheel bolts in the vehicle with the vehicle tool kit. The code number for the wheel bolt lock is stamped on the front of the adapter. A replacement adapter can be ordered based on this number if the adapter is lost. Note the wheel bolt lock code number and keep it separate from the vehicle.
- ③ Extraction hook for removing the center wheel covers, wheel hub covers, or wheel bolt covers.

Additional vehicle tool kit

Vehicles that come equipped with winter wheels have an additional tool kit inside. The additional tool kit does not always have to be carried in the vehicle.

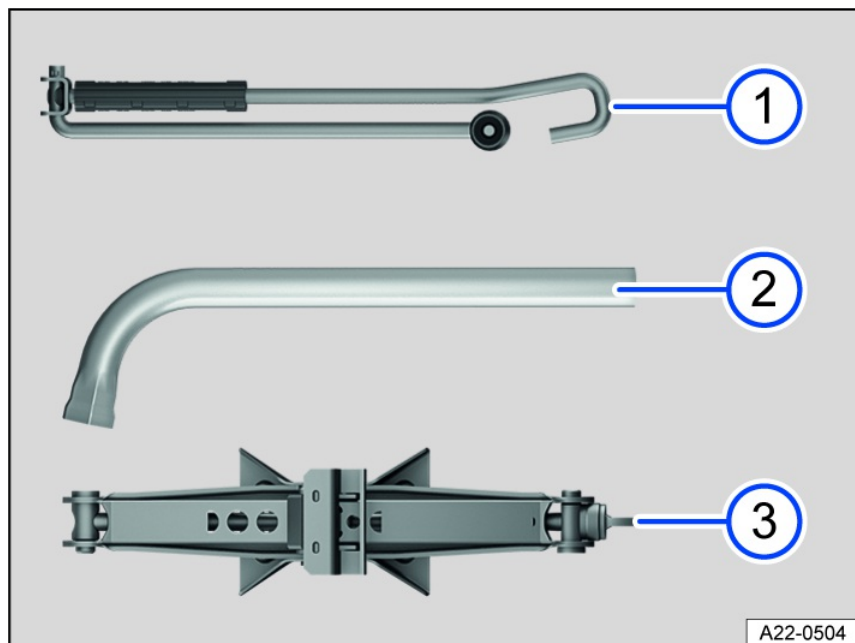

Fig. 139 Additional vehicle tool kit components (general example).

- ① Crank.
- ② Lug wrench.
- ③ Vehicle jack. Before putting the vehicle jack away, crank the vehicle jack claw all the way down.

Tire Pressure Gauge

In some countries, there may also be a tire pressure gauge in the vehicle.

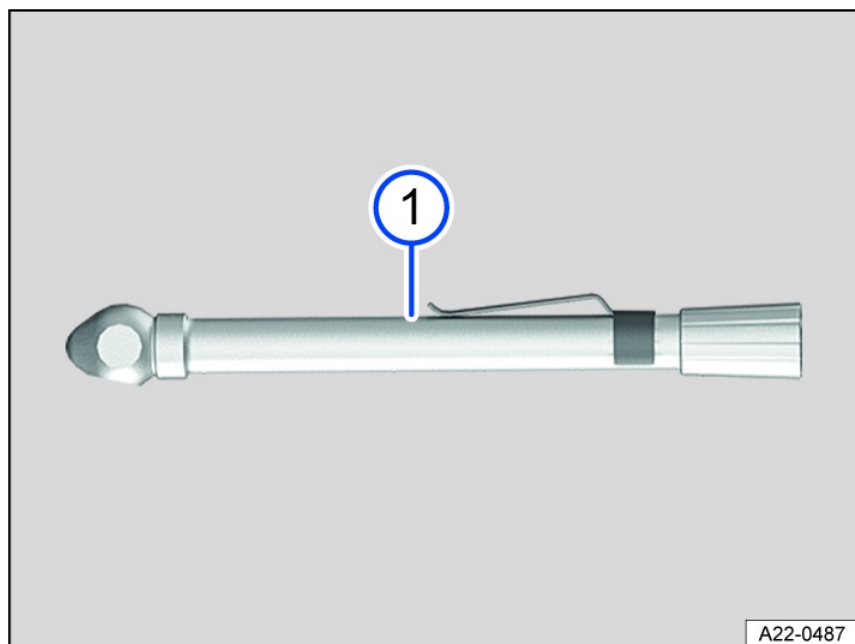

Fig. 140 Additional vehicle tool kit component (general example).

- ① Tire pressure gage (depending on the country).

Jack maintenance

If there is a jack included in the vehicle tool kit, the jack generally does not require maintenance.

1. If necessary, apply universal lubricant to the jack.

Windshield wipers

Putting the windshield wipers in the service position

In the service position, the wiper arms can be lifted off of the windshield.



Fig. 141 Windshield wipers in service position (general example).

Activate the service position using the windshield wiper lever

1. Close the hood, driver and front passenger door.
2. Switch the ignition off and on again.
3. Briefly press the windshield wiper lever towards “one-tap wiping” ⇒ *Operating the windshield wiper lever* .

Activate the service position using the exit menu

The service position of the wiper blades can also be activated in the exit menu for a limited period of time. To do this, the ignition must be switched off.

Lifting the windshield wiper arms

1. Move the windshield wiper arms into the service position before lifting ⇒ .
2. Only hold and lift wiper arms in the area where they attach to the wiper blade.

Placing the windshield wiper arms back

1. Before driving, carefully place the wiper arms back against the windshield, holding them only in the area where they attach to the wiper blade.
2. When the ignition is switched on, press the windshield wiper lever briefly towards “one-tap wiping”.

The wiper arms move back to the original position.

NOTICE

Failing to take care when working on the wiper arms can damage the hood, windshield, or wiper arms.

- Lift the wiper arms with care, and only in the service position.
- Never open the hood when the wiper arms are raised up.
- Always place the wiper arms carefully against the windshield before driving.

Cleaning and changing wiper blades

Wiper blades with a graphite coating are installed at the factory. The graphite coating allows the wiper blade to glide easily over the window. A damaged graphite coating creates an increased noise level when wiping the window.

Check the condition of the wiper blades regularly. If wiper blades are rubbing, replace them if they are damaged or clean them if they are dirty ⇒ .

Damaged wiper blades should be replaced immediately. Wiper blades can be obtained from suitably qualified professionals. Volkswagen recommends contacting an authorized Volkswagen dealer or authorized Volkswagen Service Facility.

Cleaning the wiper blades

Windshield wiper: Move the windshield wiper arms into the service position before lifting.

1. Lift the wiper arms, making sure to only hold the wiper arms in the area where they attach to the wiper blade.
2. Clean the wiper blades carefully with a damp sponge ⇒ .
3. Place the wiper arms carefully on the windshield.

Changing the windshield wiper blades

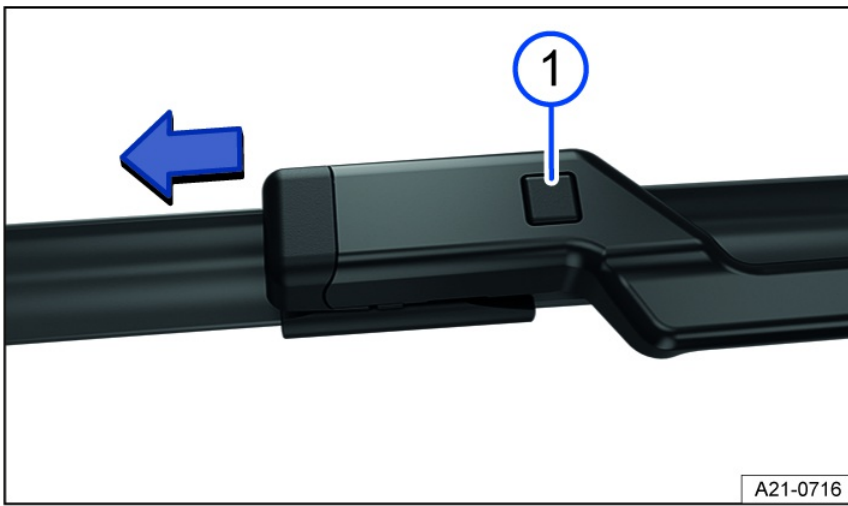

A21-0716

Fig. 142 Changing the windshield wiper blades.

① Wiper blade release button.

1. Move the windshield wiper arms into the service position before lifting.
2. Lift the wiper arms, making sure to only hold the wiper arms in the area where they attach to the wiper blade.
3. Press and hold the release button and remove the wiper blade at the same time in the direction of the arrow *fig. 142* ①.
4. Insert a new wiper blade of the same length and type on the respective wiper arm until it engages.
5. Place the wiper arms carefully on the windshield.

Changing the rear window wiper blade

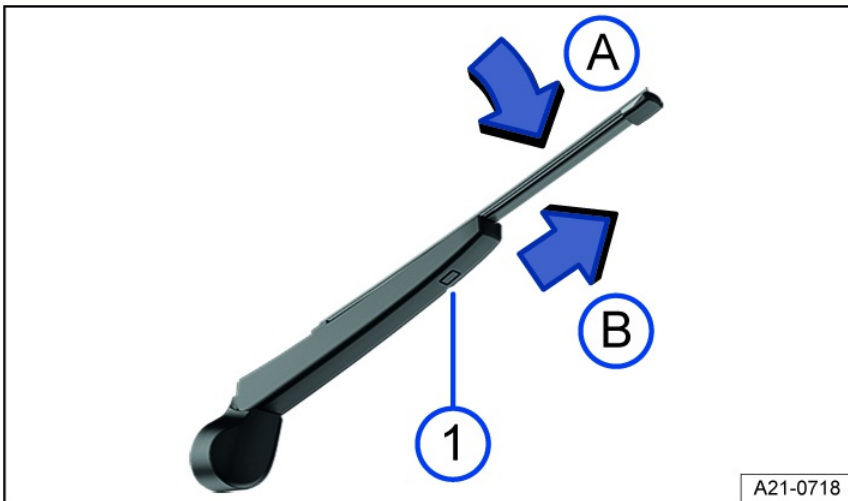

A21-0718

Fig. 143 Changing the rear window wiper blade.

① Wiper blade release button.

1. To lift a windshield wiper arm, hold it only in the area where it attaches to the wiper blade.
2. Lift the wiper arm and fold it out.
3. Press and hold the release button *fig. 143* ①.
4. Tilt the wiper blade toward the wiper arm *fig. 143* A while removing it in the direction of the arrow B. You may need to use more force to do this.
5. Slide a new wiper blade with the same length and design onto the wiper arm in the opposite direction to the arrow until it engages *fig. 143* B. For this to work the wiper blade has to be folded out *fig. 143* A.
6. Place the wiper arm carefully on the rear window.

⚠ WARNING

Worn or dirty wiper blades reduce visibility and increase the risk of accidents and serious injuries.

- Always clean dirty wiper blades.
- Always replace wiper blades if they are damaged or worn and are no longer cleaning the window glass sufficiently.

ⓘ NOTICE

Cleaning wiper blades or door windows with unsuitable cleaning agents may cause damage.

- Do not clean the wiper blades and windshield and windows with fuel, nail polish remover, paint thinner, or other similar fluids.
- Do not clean the wiper blades with rough sponges or other sharp objects.

 If there is wax residue on the windshield and rear window from car wash systems and other products, this can cause the windshield wipers to rub. Remove any wax residue with a special cleaner or cleaning towels.

Exterior lighting

Introduction

Before performing bulb replacement, check if it is an incandescent bulb or an LED light. Generally, light bulbs can be replaced by yourself. If the exterior lighting on your vehicle is equipped with LED technology, it is not possible to change LED lights or individual LEDs by yourself. The malfunction of individual LEDs may be an indication that more LEDs will malfunction. If this is the case, have the LEDs checked and/or replaced if necessary by suitably qualified professionals. Volkswagen recommends contacting an authorized Volkswagen dealer or authorized Volkswagen Service Facility.

Driving with exterior lighting that is inoperative may be against the law.

Additional bulb specifications

Some bulbs may have certain manufacturer specifications that differ from conventional light bulbs. The respective name will be on the bulb socket or glass bulb.

WARNING

If the vehicle lighting is not used appropriately for the weather conditions, the road will not be illuminated sufficiently. The vehicle will not be visible to other road users or will be difficult to see. This can cause accidents and serious or fatal injuries.

- Regularly check the vehicle's lighting system and turn signals.
- Repair the lighting system and turn signals when necessary.

WARNING

Work in the hood space can result in accidents and serious injuries if bulb replacements are carried out incorrectly.

- Always follow the tasks described and observe the general safety precautions.
- Never perform a bulb replacement if you are not familiar with the required activities.
- If you are not sure how to carry out a bulb replacement, have the work required carried out by suitably qualified professionals. Volkswagen recommends contacting an authorized Volkswagen dealer or authorized Volkswagen Service Facility.

WARNING

During the bulb replacement, the sharp-edged parts of bulb housings and hot or exploding bulbs can cause serious injuries.



- Only change bulbs when they have cooled down completely.
- Always protect your hands during bulb replacement.

NOTICE

Water entering the headlight housing can damage the electrical system.



- After a bulb replacement, always fit the covers on the headlight housing.
- After installation, always check that the covers have been secured correctly.

Information on bulb replacement

 Please read the introductory information and heed the Warnings and Notice  and  Introduction.

Always perform the following activities for bulb replacement in the specified sequence :

1. Park the vehicle a safe distance away from moving traffic on level and solid ground as soon as possible.
2. Set the electronic parking brake.
3. Switch the lights off.
4. Turn off the turn signal if it is activated.
5. End drive-ready mode.

6. Allow the orientation lighting to turn off.
7. Allow the affected light bulbs to cool down.
8. Check if you can see that a fuse is burnt out ⇒  [Introduction](#).
9. Change the affected light bulb according to the instructions ⇒ .

A light bulb may only be replaced with the same type of light bulb. The respective name will be on the bulb socket or glass bulb.

Never touch a glass light bulb with bare hands. The fingerprints left behind would vaporize from the heat when the bulb is switched on and condense on the reflector, which would then reduce the headlight brightness.

10. Check the bulb function after a bulb is changed.

If the bulb does not function, the bulb may not have been inserted correctly, may have fallen out, or the connector may not have been plugged in correctly.

11. After every bulb replacement in the front of the vehicle, have the headlight adjustment checked by an authorized Volkswagen dealer or authorized Volkswagen Service Facility. Volkswagen recommends contacting an authorized Volkswagen dealer or authorized Volkswagen Service Facility.

WARNING

If the steps described for the bulb replacement are ignored, accidents may occur. Serious injuries may result.



- Always follow the tasks described and observe the general safety precautions.

NOTICE

Removing and inserting trim panels and headlights incorrectly can damage the vehicle paint and body.

- Always be careful when removing and inserting the trim panels and headlights.

Replacing bulbs in LED headlights

 Please read the introductory information and heed the Warnings and Notice ⇒  and  [Introduction](#).

Preparations

Only perform these activities in the specified order:

1. Refer to the information on bulb replacement and carry out the activities.
2. Open the hood.

The headlight does not need to be removed for bulb replacement.

Replacing a bulb in a turn signal

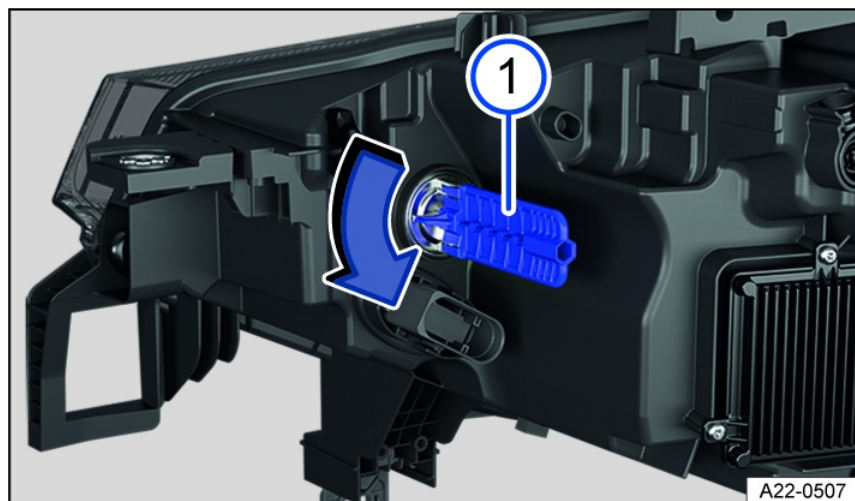



Fig. 144 In the right-side of the hood space: rear side of the headlights.

 Turn signal bulb holder.

1. To remove, turn the bulb holder in the direction of the arrow [fig. 144](#) .
2. Replace the burned out bulb with a new bulb that is identical to the one being replaced.
3. Carefully insert the bulb holder into the headlight and turn in the opposite direction to the arrow [fig. 144](#) .
4. Close the hood.

 The illustration shows the right headlight from behind. The left headlight is structured as its mirror image.

Replacing fuses

Introduction

Due to the constant development of the vehicle, equipment-dependent fuse allocations, and the combined protection of multiple electrical equipment items using one fuse, a complete overview of the fuse layout is not available at the time of print. Detailed information about fuse allocations can be obtained from suitably qualified professionals. Volkswagen recommends contacting an authorized Volkswagen dealer or authorized Volkswagen Service Facility.

Generally, multiple electrical equipment items can be protected together through by fuse. On the other hand, some equipment items may use multiple fuses.

Only replace fuses if the cause for the malfunction has been fixed. If a new fuse blows again after a short time, the electrical system must be checked by suitably qualified professionals. Volkswagen recommends contacting an authorized Volkswagen dealer or authorized Volkswagen Service Facility.

Fuses for emergency responders

One of the high-voltage system fuses in the fuse box in the instrument panel → *Fuses in the instrument panel* is marked with a special flag to allow emergency responders to switch off the vehicle power as quickly as possible. Never replace this fuse yourself or swap it with a fuse from a different fuse location → . If this fuse is malfunctioning, always have it replaced by suitably qualified professionals. Volkswagen recommends contacting an authorized Volkswagen dealer or authorized Volkswagen Service Facility.

WARNING

Voltage in the high-voltage system can cause electric shocks, serious burns and death!

- Never touch the electrical wires in the hood space
- Never replace or repair fuses of the high-voltage system yourself.
- Always have the work performed by an authorized Volkswagen dealer or authorized Volkswagen Service Facility qualified in this respect. Volkswagen recommends contacting an authorized Volkswagen dealer or authorized Volkswagen Service Facility.

WARNING

Using unsuitable fuses, repairing fuses, and bridging a power circuit without fuses can cause severe damage or fires within the vehicle. This could result in serious or fatal injuries.

- Replace fuses only with fuses of same rating and size. Make sure that the color and label are identical to the faulty fuse.
- Never repair fuses.
- Never use metal strips, paper clips or similar objects as substitutes for fuses.

NOTICE

The high-voltage fuses marked with a special flag in the fuse box in the instrument panel are for use by emergency responders only in order to switch off the vehicle power in an emergency. If these high-voltage fuses are removed incorrectly, the vehicle could be damaged.

- Never remove the fuses marked with a special flag in the instrument panel.
- If the high-voltage system has switched off, seek assistance from an authorized Volkswagen dealer or authorized Volkswagen Service Facility. The vehicle is no longer ready to drive.

NOTICE

Changing a fuse when the ignition is switched on, the vehicle is drive-ready, the light is switched on, or other electrical equipment is switched on could cause damage to the electrical system.

- Always deactivate the vehicle's drive system and switch off the light and other electrical equipment.
- Make sure that the drive-ready mode cannot be established while a fuse is being replaced.

NOTICE

If a fuse is replaced by another fuse with a higher amp rating, this could also damage the vehicle's electrical system in another location.

- Never replace a fuse with a fuse that has a higher current rating.

NOTICE

Dirt and moisture in the fuse boxes can damage the electrical system.

- Protect open fuse boxes from dirt and moisture.

- Avoid short circuits in the electrical system.
- Check that the fuse box covers are tightly sealed again and are not damaged.

 There are more fuses in the vehicle than are specified in this chapter. These should only be replaced by an authorized Volkswagen dealer or authorized Volkswagen Service Facility qualified in this respect. Volkswagen recommends contacting an authorized Volkswagen dealer or authorized Volkswagen Service Facility.

Fuses in the hood space

 Please read the introductory information and heed the Warnings and Notice  and  Introduction.

Opening the fuse box in the hood space

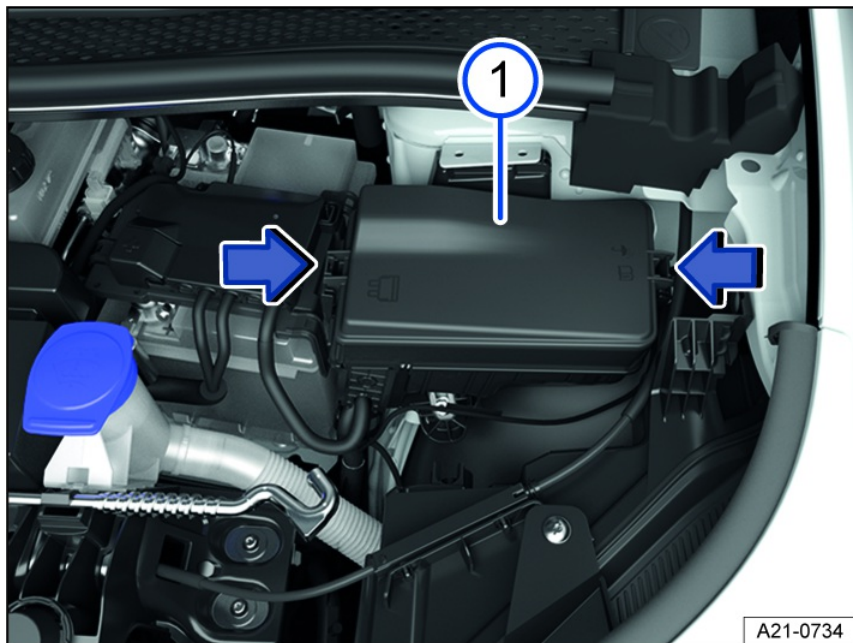



Fig. 145 In the hood space: fuse box.

 Fuse box cover.

The fuse box cover may contain plastic pliers for pulling out the fuses.



Removing the cover

1. Open the hood.
2. Press the catches in the direction of the arrow *fig. 145* (arrows), to release the fuse box cover *fig. 145* .
3. Remove the cover upward.

Fitting the cover

1. Place the cover on the fuse box and press it down until the cover audibly clicks into place on both sides.

Fuse table for fuses in the hood space

 Please read the introductory information and heed the Warnings and Notice  and  Introduction.

The list shows the fuse locations for the equipment relevant to the driver. The first column of the table contains the fuse location; the other columns include the rate current, fuse version and the protected equipment.

Depending on the country and the vehicle equipment, there may be differences from the fuse numbers and fuse locations listed in the table. If necessary, ask for the exact fuse assignment from suitably qualified professionals. Volkswagen recommends contacting an authorized Volkswagen dealer or authorized Volkswagen Service Facility.

Fuse assignment

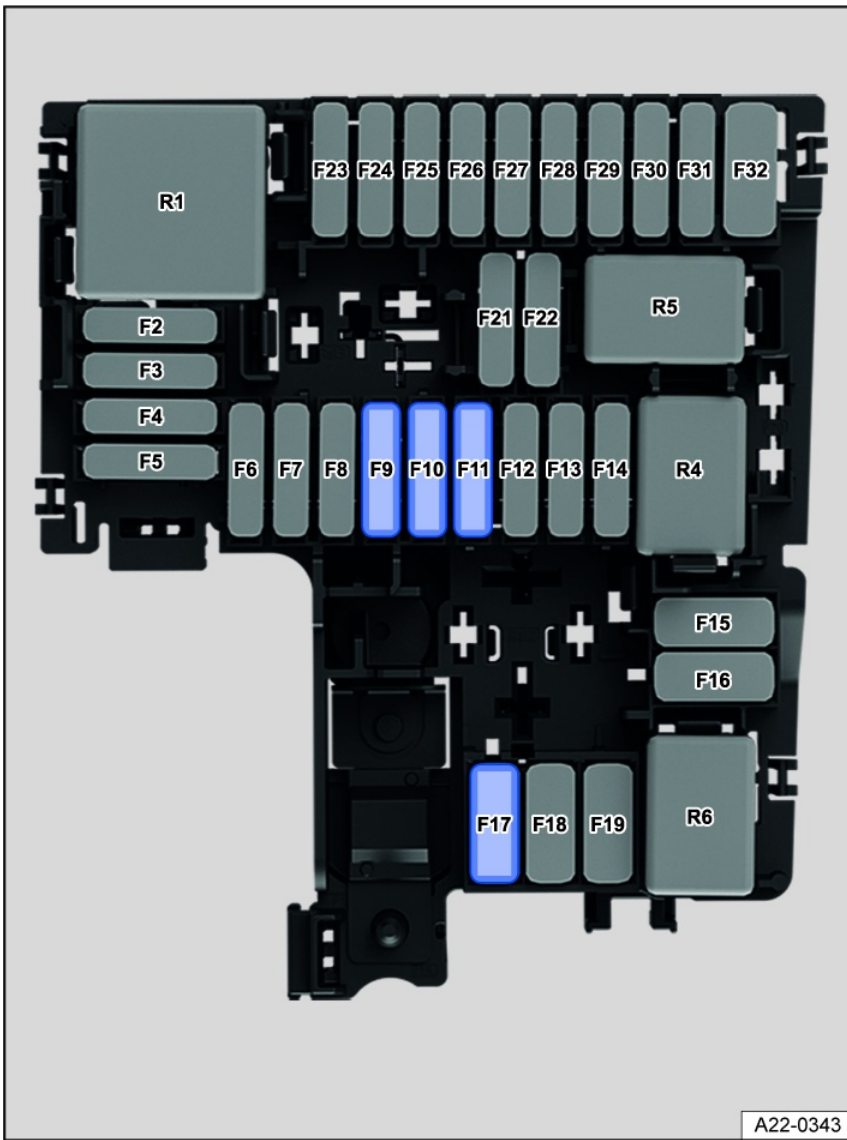

A22-0343

Fig. 146 In the hood space: Fuse locations.

Fuse location *fig. 146*:

- F9** 15 A, ATO®, horn.
- F10** 30 A, ATO®, front left windshield wiper.
- F11** 7.5 A, ATO®, air conditioner.
- F17** 40 A, MAXI+®, windshield defroster.

Fuses in the instrument panel

📖 Please read the introductory information and heed the Warnings and Notice ⇒ ⚠️ and ⓘ *Introduction*.

Left-hand drive vehicles: Opening the fuse box in the instrument panel



A22-0410

Fig. 147 Fuse box cover on the instrument panel on the driver's side (left-hand drive vehicles).

Removing the cover

1. Reach behind the cover and pull it off in the direction of the arrow *fig. 147*.

Fitting the cover

1. Position the cover starting with the opposite side and push it closed in the opposite direction to the arrow until you hear it click into place.

Right-hand drive vehicles: opening the fuse box in the instrument panel

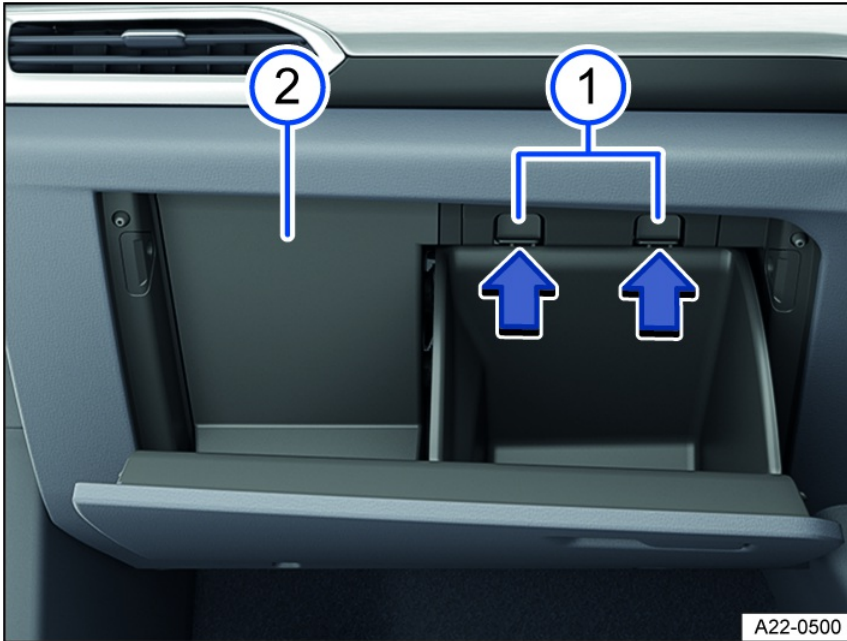

Fig. 148 On the passenger's side: Fuse box in the instrument panel (right-hand drive vehicles).

- ① Stop pin.
- ② Cover

Removing the cover

1. Open the glove compartment and empty it if necessary.
2. Push the catches in the direction of the arrow while at the same time opening the glove compartment further *fig. 148* ①.
3. Reach to the side behind the cover and pull it backward *fig. 148* ②.

Fitting the cover

1. Reinsert the cover and press it forward until the cover is reengaged.
2. Close the glove box.

Fuse table for fuses in the instrument panel

📖 Please read the introductory information and heed the Warnings and Notice ⇒ ⚠ and ⚠ Introduction.

The list shows the fuse locations for the equipment relevant to the driver. The first column of the table contains the fuse location; the other columns include the rate current, fuse version and the protected equipment.

Depending on the country and the vehicle equipment, there may be differences from the fuse numbers and fuse locations listed in the table. If necessary, ask for the exact fuse assignment from suitably qualified professionals. Volkswagen recommends contacting an authorized Volkswagen dealer or authorized Volkswagen Service Facility.

Fuse assignment

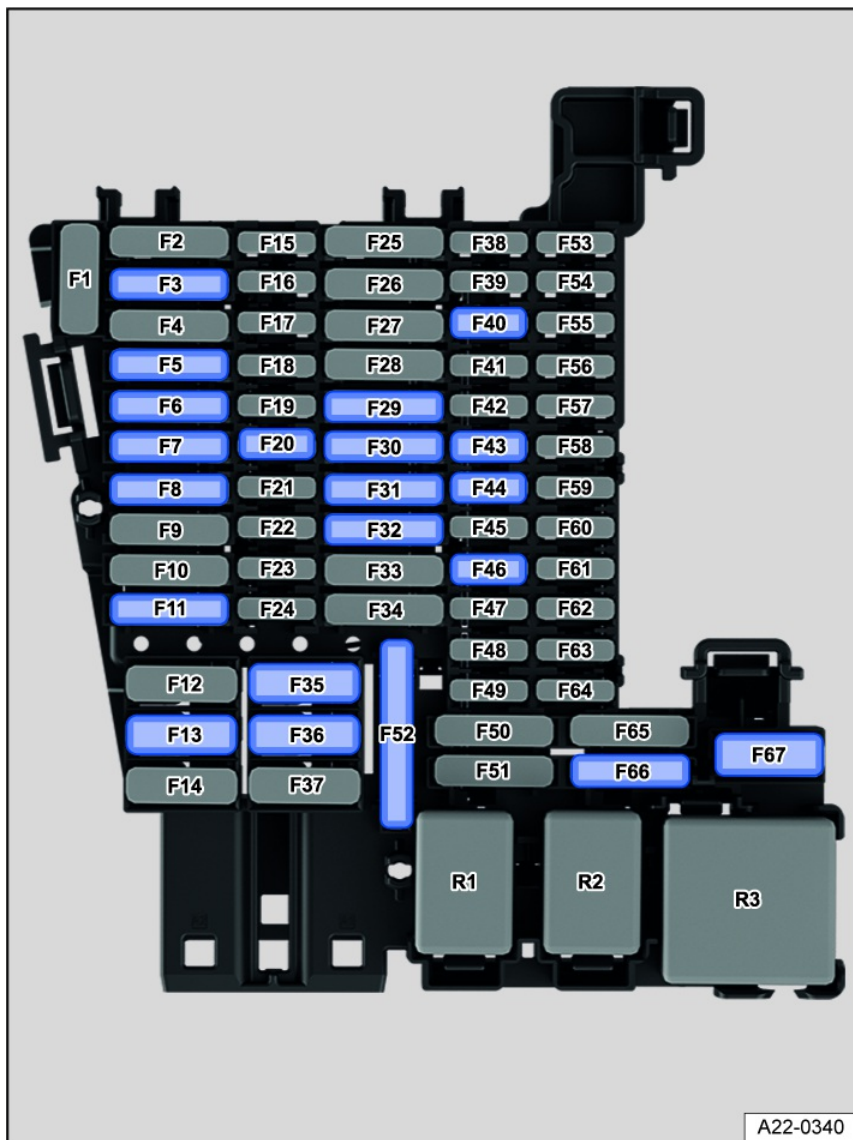

Fig. 149 Fuse assignment in the instrument panel.

Fuse location *fig. 149*:

- F5** 25 Amp, ATO®, exterior lighting on the left side.
- F6** 30 Amp, ATO®, interior lighting.
- F7** 30 Amp, ATO®, seat heating.
- F13** 40 A, MAXI+®, central locking.
- F20** 10 Amp, MINI®, telephone.
- F30** 20 A, ATO®, Infotainment system scope.
- F32** 25 Amp, ATO®, exterior lighting on the right side.
- F35** 40 A, MAXI+®, rear seat heating.
- F36** 40 A, MAXI+®, blower regulator.
- F40** 10 Amp, MINI®, anti-theft alarm system.
- F43** 7,5 amp, MINI®, climate control bar, rear window defroster relay.
- F44** 7.5 A, MINI®, light switch (dipped beam), rain/light sensor, ambient lighting, ID. Light.
- F46** 10 Amp, MINI®, Display, Infotainment system control panel.
- F52** 20 Amp, ATO®, cigarette lighter, sockets.
- F66** 15 Amp, ATO®, rear window wiper.
- F67** 30 A, MAXI+®, rear window heating.



Fuse locations in vehicles with a factory-installed trailer hitch:

- F3 25 A, ATO®, control module for left trailer detection.
- F11 15 A, ATO®, control module for trailer detection.
- F29 15 A, ATO®, control module for trailer detection.
- F31 25 A, ATO®, control module for right trailer detection.

 Power windows and seats can be protected by circuit breakers or control modules, which switch back on automatically several seconds after correcting the overload, for example when door windows are frozen shut.

³⁾Note the installation position. Factory-standard fuse location as shown in the illustration.

Replacing blown fuses

 Please read the introductory information and heed the Warnings and Notice  and  Introduction.

Preparations

1. Deactivate drive-ready mode and switch off the lights and all other electrical equipment.

Detecting blown fuses

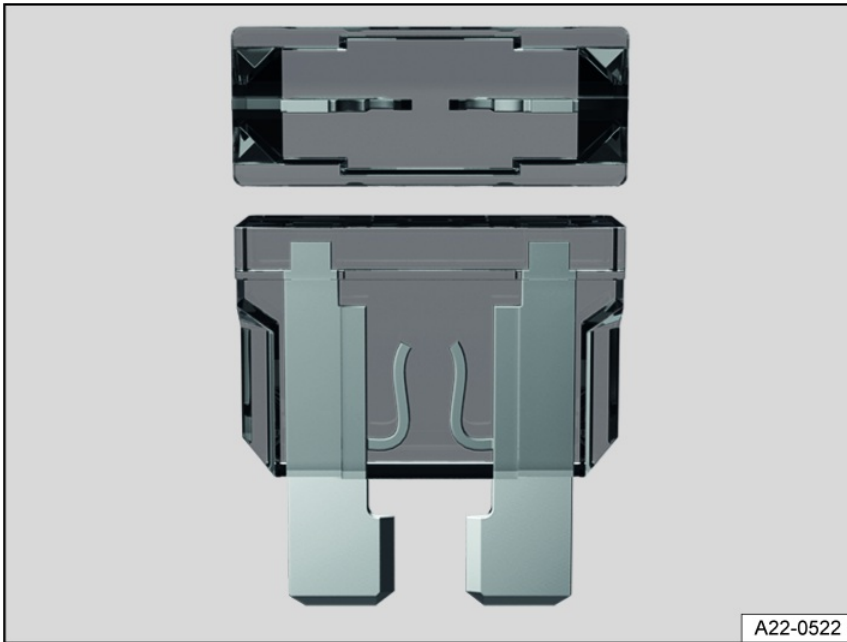

Fig. 150 Blown fuse (general example).

1. Shine a flashlight on the fuses.

A blown fuse can be recognized from above and from the side through the transparent casing, as its metal strip will be burnt through [fig. 150](#).

Fuse versions

- Standard flat connector fuse (ATO®).
- Small flat connector fuse (MINI®).
- Large flat blade fuse (MAXI® or MAXI+®).

Fuse color codes

Fuses (ATO® - MINI® - MAXI® or MAXI+®).

Color *Current rating*

Black 1 A

Purple 3 A

Orange 5 A

Brown 7.5 A

Red 10 A

Blue 15 A

Yellow 20 A

White or clear 25 A

Green 30 A

Light green 40 A

Replacing fuses



Fig. 151 Plastic pliers for removing or installing a fuse (general example).

1. If necessary, remove the plastic tongs from either the fuse box or the cover of the fuse box [fig. 151](#).
2. Depending on the design of the fuse, slide the appropriately sized clamp on the plastic pliers onto the fuse from above or from the side.
3. Remove the fuse.
4. If a fuse is blown, replace with a fuse with the same rating (same color and same label) and the same size ⇒ .
5. After inserting the new fuse, place the plastic pliers back in the cover, if necessary.
6. Reinstall the cover or close the fuse box cover.

NOTICE

If a fuse is replaced by a fuse with a higher current rating, this could damage the electrical system in another location.

- Never replace a fuse with a fuse that has a higher current rating.

Jump-starting

Introduction

The vehicle must not be tow started for technical reasons. If the vehicle's drive system cannot be engaged because the 12 V vehicle battery is dead, the 12 V vehicle battery on another vehicle can be used to engage your vehicle's drive system.

For technical reasons, the jump-start points in electric vehicles are not designed for use in jump-starting other vehicles ⇒ .

WARNING

Using jumper cables incorrectly and performing a jump-start incorrectly could cause the 12 V vehicle battery to explode. Serious injuries may result.

- Always read and heed the warnings and safety precautions before working on the 12 V vehicle battery ⇒  [Introduction](#).
- Never confuse the positive battery terminal with the negative battery terminal.
- Never jump-start a vehicle with a frozen or thawed 12 V vehicle battery.

WARNING

During a jump-start, a highly explosive gas mixture builds up at the 12 V vehicle battery. Sparks produced during a jump-start could ignite the flammable gas. Serious injuries may result.

- Always keep fires, sparks, open flames, and lit cigarettes far away from the 12 V vehicle battery.
- Avoid discharging static electricity near the 12 V vehicle battery.

NOTICE

The electrical system of an electric vehicle is not designed to give jump-starts to other vehicles. This can cause significant damage to the electrical system of an electric vehicle.

- Never use an electric vehicle to jump-start another vehicle.

NOTICE

A drained 12 V vehicle battery can freeze, be damaged and fail at temperatures around approx. 0 °C (approx. +32 °F).

- Always replace a frozen or thawed 12 V vehicle battery.

Ground jump-start point

📖 Please read the introductory information and heed the Warnings and Notice ⇒ ⚠️ and ⓘ Introduction.

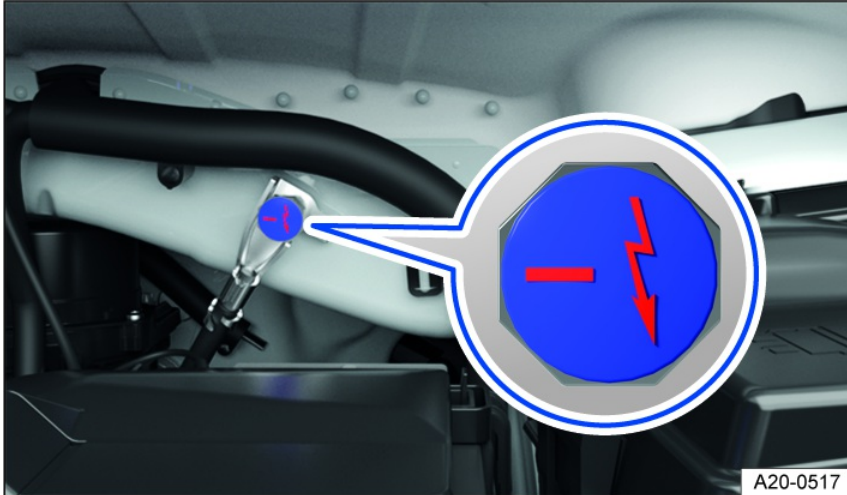

Fig. 152 In the hood space: Negative terminal jump-start point.

- The jump-start point (negative terminal) is for connecting the black jumper cable *fig. 152*.

To reduce the risk of considerable damage to the vehicle electrical system, it is not permitted to jump-start other vehicles with an electric vehicle.

The vehicle can receive a jump-start using this negative terminal jump-start point.

Positive jump-start point

📖 Please read the introductory information and heed the Warnings and Notice ⇒ ⚠️ and ⓘ Introduction.

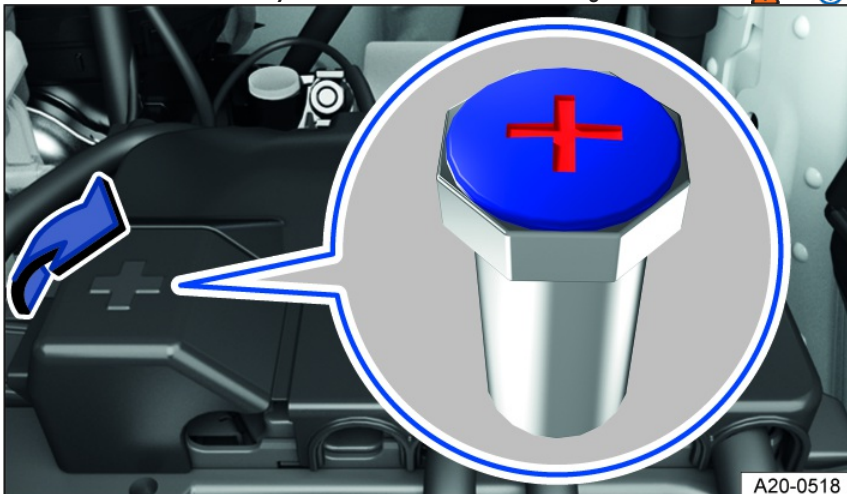

Fig. 153 Under a cover in the hood space: Positive jump-start point.

- ⊕ The jump-start point (positive battery terminal) for connecting the red jumper cable is located under a cover in the hood space.

To reduce the risk of considerable damage to the vehicle electrical system, it is not permitted to jump-start other vehicles with an electric vehicle. The jump-start point is not designed for jump-starting other vehicles.

The vehicle can receive a jump-start using this positive terminal jump-start point.

Preparing and Performing a Jump-start

📖 Please read the introductory information and heed the Warnings and Notice ⇒ ⚠️ and ⓘ Introduction.

Preparations

Observe the following for jump-starting:

- Wear suitable eye protection and safety gloves ⇒ ⚠.
- Pay attention to the operating instructions provided by the manufacturer of the jump-start cables.
- Open the hood.
- Always use a jumper cable with fully insulated terminal clamps and without any insulation defects for jump-starting ⇒ ⚠.
- Ensure that there is sufficient distance between the vehicle providing the jump-start and the vehicle receiving the jump-start, otherwise current could already flow when connecting the positive battery terminals.
- Make sure the terminal clamps have sufficient contact with metal.

Jumper cable

So that vehicles can be jump-started, an appropriate jumper cable is required.

The following jumper cable wire diameters must not be fallen short of by the vehicle providing the jump-start.

- Vehicles with electric drivetrain: To jump-start the vehicle with a drained 12 V vehicle battery, the wire diameter of the jumper cable must be at least 25 mm² (0.038 in²).

Vehicle Receiving the Jump-start

1. Check that the discharged 12 V vehicle battery is properly connected to the 12 V vehicle electrical system.
2. If a 12 V vehicle battery with a viewing window has been installed, check the color of the viewing window. If the viewing window is light yellow or has no color, do not perform a jump-start and contact an authorized Volkswagen dealer or authorized Volkswagen Service Facility.

Vehicle Providing the Jump-start

1. Pay attention to the operating instructions provided by the vehicle manufacturer.
2. Check that the battery providing the jump-start has the same voltage (12 V) and approximately the same battery capacity as the dead 12 V vehicle battery. Pay attention to the information printed on the battery of the vehicle providing the jump-start.

Jump-starting

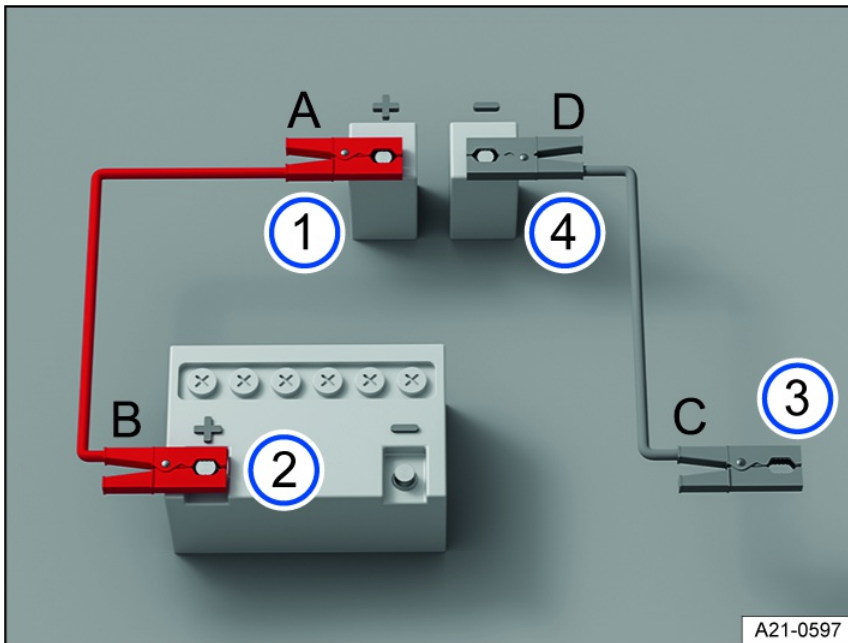





Fig. 154 Diagram for connecting the jumper cables.

- ① Positive jump-start point of the electric drivetrain vehicle receiving the jump-start.
- ② Positive battery terminal of the vehicle providing the jump-start.
- ③ Suitable negative terminal of the vehicle providing the jump-start. Preferably a jump-start point (negative), otherwise a large metal part that is bolted securely to the engine block, or the engine block itself.
- ④ Jump-start point (negative) of the electric drivetrain vehicle receiving the jump-start.

Only connect the jumper cables in the sequence A – B – C – D *fig. 154*.

1. Switch the ignition off on both vehicles.
2. In the hood space, open the cover on the positive jump-start point (+), if fitted.
3. Connect one end of the red jumper cable to the positive jump-start point (+) of the vehicle with the discharged 12 V vehicle battery *fig. 154* ① ⇒ ⚠.
4. Connect the other end of the red jumper cable to the positive battery terminal (+) on the vehicle providing current *fig. 154* ②.

5. Connect one end of the black jumper cable preferably to the negative terminal (-) jump-start point on the vehicle with the 12 V vehicle battery providing current *fig. 154* .
- Or:** If there is no negative terminal (-) jump-start point, connect the end of the black jumper cable to a large metal part that is bolted securely to the engine block, or the engine block itself, on the vehicle with the 12 V vehicle battery providing current *fig. 154* .
6. Connect the other end of the black jumper cable to the negative terminal (-) jump-start point on the vehicle with the discharged 12 V vehicle battery *fig. 154* .
7. Route the jumper cables so that they cannot become caught in moving parts in the hood space.

Activating the vehicle's drive system

1. Start the engine in the vehicle that is providing current and allow it to idle.
2. Activate the vehicle's drive system in the vehicle with the discharged 12 V vehicle battery. If the vehicle's drive system cannot be activated, stop the starting process after 10 seconds, and try again after approximately 1 minute.

If the vehicle's drive system still cannot be activated, contact an authorized Volkswagen dealer or authorized Volkswagen Service Facility.

Removing the jumper cables

1. Before disconnecting the jumper cables, switch off the low beam headlight if necessary.
2. In the vehicle with the drained 12 V vehicle battery, switch on the blower for the air conditioner and the rear window defroster. This will reduce any voltage surges that may occur when disconnected.
3. Once the vehicle has been jump-started, always disconnect the jumper cables in the order D – C – B – A *fig. 154*.
4. Close the cover of the positive battery terminal (+) jump-start point, if fitted.

After successful jump-starting, have the 12 V vehicle battery checked by an authorized Volkswagen dealer or authorized Volkswagen Service Facility. Volkswagen recommends contacting an authorized Volkswagen dealer or authorized Volkswagen Service Facility.

WARNING

Performing a jump-start incorrectly can cause the 12 V vehicle battery to explode, which can cause serious injuries.

- Always wear suitable eye protection and safety gloves.
- Never bend over the 12 V vehicle battery.
- Always connect the positive cable first and then the negative cable.
- Never connect the negative cable to the brake lines.
- Ensure that there is no contact between the non-insulated parts of the terminal clamps.
- Make sure the cable insulation is free from any defects.
- Make sure that the cable that is connected to the positive battery terminal on the 12 V vehicle battery does not come into contact with any vehicle components that conduct electricity.

NOTICE

A drained 12 V vehicle battery can freeze, be damaged and fail at temperatures around approx. 0 °C (approx. +32°F).

- Always replace a frozen or thawed 12 V vehicle battery.

Towing

Introduction

Towing requires practice, particularly if a towing cable is used. Both drivers should be familiar with the special considerations when towing. Inexperienced drivers should not tow.

Follow all applicable laws when towing.

Always make sure the towing force does not exceed the permitted level and there are no shock loading conditions. There is always the risk of the coupling becoming overloaded when driving off-road.

WARNING

The vehicle handling and braking efficiency will change considerably when it is towed. This may cause you to lose control of the vehicle and result in accidents and serious or fatal injuries.

- Bear in mind that more force is required for steering and braking during towing.

WARNING

If a vehicle that has no electrical power is towed, the electronic steering lock may suddenly engage. If this happens, you will not be able to move the steering wheel. This can cause accidents and serious or fatal injuries.

- Never turn off the ignition with the starter button while towing.
- If the vehicle loses power while it is being towed, stop towing the vehicle immediately and see an authorized Volkswagen dealer or authorized Volkswagen Service Facility for assistance.

NOTICE

When pushing the vehicle by hand, the taillights, side spoiler on the rear window and large sections of sheet metal could be damaged and the rear spoiler could detach.

- When pushing the vehicle by hand, do not press on the taillights, side spoiler on the rear window, large sections of sheet metal, or the rear spoiler.

Towing

Towing refers to using a vehicle to pull another vehicle that cannot be driven.

The vehicle can be towed using a tow bar or tow rope:

- The maximum permissible speed is 50 km/h (30 mph).
- The maximum permissible distance is 50 km/h (30 miles).

The easiest and safest way to tow is using a tow bar. You should use a towing cable only if a tow bar is not available. The towing cable should be elastic to protect both vehicles. Use a cable made of synthetic rubber or a similar elastic material.

Towing with a tow truck

The vehicle must be towed with all four wheels on a tow truck.

WARNING

Vehicle components can be badly damaged by incorrectly attached tow ropes or tow bars. This increases the risk of accident and could result in serious or fatal injuries.

- Only ever secure the vehicle to be recovered and towed at the points designed for this purpose.
- Never secure the tow rope or the tow bar to axle or suspension components.
- Contact an authorized Volkswagen dealer or authorized Volkswagen Service Facility and have the vehicle taken away on a tow truck, if necessary.

Instructions for towing

 Please read the introductory information and heed the Warnings and Notice  and  Introduction.

A vehicle being towed can still signal a turn using the turn signals even if the emergency flashers are switched on. To do this when the ignition is switched on, activate the turn signal for the desired direction. The emergency flashers will stop while the turn signal is active. The emergency flashers will automatically activate again once the turn signal and high beam lever returns to the neutral position.

When may this vehicle not be towed?

The vehicle must not be towed in the following situations:

- If the 12 V vehicle battery is drained.
- A red warning light  and the Towing: Damaged e-system – see manual! message will appear the instrument cluster display.
- The power supply to the 12-volt vehicle electrical system cannot be secured.
- The indicator in the instrument cluster display does not function perfectly.
- If the towing distance is greater than approx. 50 km (approx. 30 miles).
- The driving mode selector cannot be moved to idle (position N).
- The anti-roll function cannot be deactivated.
- The electronic parking brake cannot be released.
- The steering lock cannot be released.
- If the wheel clearance or the steering function can no longer be secured after an accident.

If the vehicle cannot be towed on its own wheels due to one of the conditions listed, contact professional assistance and have the vehicle transported by a tow truck if necessary. Inform the relevant people, particularly the organizing office and transportation, that an electric vehicle is involved.

Towing

📖 Please read the introductory information and heed the Warnings and Notice ⇒ ⚠️ and ⓘ Introduction.

If the towing conditions have not been met, the vehicle may be pushed or towed on its own four wheels only in emergency situations. The vehicle may be towed to the tow truck only at walking pace and up to a maximum of 100 meters ⇒ ⚠️.

⚠️ WARNING

If you tow your vehicle in spite of the message Towing damages the electrical system. Owner's manual! appearing in the instrument cluster, vibrations could occur in the drive system and the driven wheels could lock, particularly on ice or wet roads. Wheels that lock may cause you to lose control of the vehicle or lead to accidents and serious or fatal injuries.

- If the message Towing damages the electrical system. Owner's manual! appears in the instrument cluster, do not push or tow the vehicle unless it is an emergency.

Secure the tow rope or tow bar only at the permitted points:

- Towing lug.
- Ball mount.

⚠️ WARNING

Vehicle components can be badly damaged by incorrectly attached tow ropes or tow bars. This increases the risk of accident and could result in serious or fatal injuries.

- Only ever secure the vehicle to be recovered and towed at the points designed for this purpose.
- Never secure the tow rope or the tow bar to axle or suspension components.
- Contact an authorized Volkswagen dealer or authorized Volkswagen Service Facility and have the vehicle taken away on a tow truck, if necessary.

Preparations

- Make sure the tow rope is not twisted. Otherwise it could disconnect from the towing eye while towing.
- Switch the ignition and emergency flashers on in both vehicles. However, do not do this if it is prohibited by law.
- Read and comply with the information and instructions for towing given in the Owner's Manual for the other vehicle.

Towing vehicle (front)

1. Only start to drive when the tow rope is taut.
2. Be especially careful when accelerating.
3. Avoid sudden braking and driving maneuvers.
4. Do not exceed the permitted towing weight of the vehicle.

Vehicle being towed (rear)

1. Make sure the ignition is always switched on so that the steering wheel is not locked and so that the turn signal and windshield wiper can be used if needed. The brake booster and power steering only work when the ignition is switched on. Otherwise, the brake pedal needs to be pressed much harder and more force is required to steer.
2. Make sure the vehicle key is always in the vehicle during the towing process.
3. Select gear **N**.
4. Deactivate the anti-roll function ⇒ *Electronic parking brake*.
Or: The driver remains seated in the driver seat throughout the towing process and always wears their safety belt, and the driver door is closed.
5. Ensure that the electronic parking brake is always switched off throughout the towing process ⇒ ⓘ.
6. Make sure the tow rope is always taut.

ⓘ NOTICE

If the electronic parking brake switches on during the towing process, wheels may lock. Serious damage to the vehicles may result.

- End the towing process immediately.
- Contact an authorized Volkswagen dealer or authorized Volkswagen Service Facility and have the vehicle taken away on a tow truck, if necessary.

ⓘ NOTICE

If the battery charge level of the 12 V vehicle battery is insufficient, you will not be able to release the electronic parking brake and steering lock. The vehicle may be damaged when towed.

- To release the electronic parking brake and steering lock, put the vehicle into drive-ready mode, if necessary by means of a jump-start if there is a loss of power or malfunctions.
- Contact an authorized Volkswagen dealer or authorized Volkswagen Service Facility and have the vehicle taken away on a tow truck, if necessary.

Rear towing eye

📖 Please read the introductory information and heed the Warnings and Notice ⇒ ⚠️ and ⓘ Introduction.

A pulling eye for tow truck is installed on the driver's side underneath the bumper cover so that the vehicle can be pulled onto a tow truck fig. 155, ⇒ ⚠️.



Fig. 155 At the rear of the vehicle: pulling eye for tow truck installation location.

The pulling eye for tow truck is only intended for a tow rope or tow chain.

⚠️ WARNING

Using the pulling eye for tow truck to tow other vehicles may damage the vehicle or cause accidents and serious or fatal injuries.

- Only use the pulling eye for tow truck to have your own vehicle pulled onto a tow truck.
- Never tow another vehicle with the pulling eye for tow truck.

Vehicles with a trailer hitch

Vehicles with a factory-installed trailer hitch do not have a pulling eye for tow truck at the rear of the vehicle.

1. Install the ball mount and use it for towing.

ⓘ NOTICE

Using an unsuitable towing bar could damage the ball hitch and the vehicle.

- Always use a tow bar specifically designed for mounting on a ball mount for towing.
- If you do not have a suitable tow bar, use a tow rope for towing.

Checking and filling

In the hood space

Safety precautions for working in the hood space

The hood space of a vehicle is a dangerous area. Only perform work in the hood space if you are familiar with the necessary activities and the general safety precautions, and if the correct operating equipment, fluids and suitable tools are available. Work performed incorrectly can result in serious injuries ⇒ . Have all work performed by suitably qualified professionals if necessary. Volkswagen recommends contacting an authorized Volkswagen dealer or authorized Volkswagen Service Facility.

WARNING

The hood space is a dangerous area. Any work in the hood space could lead to accidents and serious or fatal injuries.

- Always work as cautiously and carefully as possible.
- Do not perform work in the hood space unless you are familiar with the required activities.
- If you are not sure how to do the work in the hood space, have the work required carried out by suitably qualified professionals. Volkswagen recommends contacting an authorized Volkswagen dealer or authorized Volkswagen Service Facility.
- Set the electronic parking brake before working in the hood space.
- Switch off the ignition and store the vehicle key securely and far enough away from the vehicle to ensure that the vehicle's drive system cannot be activated accidentally and the electrical system cannot be powered unintentionally.
- Never touch hot components of the electric drivetrain.
- Do not leave any items, such as cleaning cloths or tools, in the hood space.
- Always keep children away from the hood space and never leave them unattended.

WARNING

The hood space contains moving components. When working in the hood space, particularly when starting the vehicle or if the vehicle is drive-ready, contact with moving parts, e.g. fan blades in the radiator fan, may cause serious or fatal injuries.

- Never reach into the radiator fan or into the area near the radiator fan even with the ignition or the vehicle's drive system switched off. The ventilator is temperature-controlled and may switch on by itself.
- To reduce the risk of anything becoming caught in electric drivetrain components, always remove any jewelry and/or ties, tie back long hair, and avoid wearing loose-fitting clothing when performing work.
- Always press the accelerator pedal extremely carefully and never press it without paying close attention. The vehicle could begin moving, even if the electronic parking brake is set.

WARNING

Escaping hot steam or hot coolant and hot components may cause serious burns.

- Never open or close the hood if steam or engine coolant is escaping.
- Always wait until you can no longer see or hear steam or engine coolant escaping from the hood space.

WARNING

The motor cooling system is under pressure when the electric motor is hot. If the cover is opened carelessly, coolant may spray out and cause serious burns or fatal injuries.

- Never open the cap on the coolant expansion tank when the electric drivetrain is hot.
- Always protect your face, hands and arms from hot coolant or steam with a large, thick cloth if you have to open the cover of the coolant tank.
- Slowly and very carefully turn the cap on the coolant expansion tank counterclockwise while pressing down lightly on the cap.

WARNING

Additional insulating materials, such as covers in the hood space, or discarded items, such as cleaning cloths or tools, can cause malfunctions, damage to the electric drivetrain or fires. This could result in serious or fatal injuries.

- Never cover the electric drivetrain with blankets or other insulating materials.
- Never leave items in the hood space.

Always make sure the vehicle is parked on a firm, flat surface before performing any work in the hood space of the vehicle ⇒ ⚠.

⚠ WARNING

If the vehicle is not secured against rolling away during maintenance procedures, the vehicle may move unintentionally. This could result in accidents and serious or fatal injuries.

- Never work underneath the vehicle when it has not been correctly secured to prevent it from rolling.
- If working under the vehicle with the wheels touching the floor, ensure the vehicle is on a level surface and the wheels are secured.
- If you are working underneath the vehicle, additionally support the vehicle securely with suitable stands. The vehicle jack is not sufficient for this purpose and may collapse.

Work on the high-voltage system may only be performed by qualified personnel who are trained to follow the Volkswagen guidelines ⇒ ⚠. The high-voltage battery must be checked by a qualified and trained specialist after a collision or after the vehicle runs into an obstacle.

⚠ DANGER

The components of the high-voltage system carry high electrical voltage. Contact with live components of the high-voltage system causes burns, serious injuries or fatal electric shocks.

- Always assume that the high-voltage battery is fully charged and that all the high-voltage components are live. This may be the case even if the ignition is switched off.
- Never touch high-voltage components or orange high-voltage cables. Damage to high-voltage components is not always obvious.
- Never remove the orange high-voltage cables and never damage or modify them.
- Never disconnect the high-voltage cable from the high-voltage system.
- Never open or modify the cover of the high-voltage battery and never remove it.
- Never perform any work in the vicinity of high-voltage components or high-voltage cables using cutting, shaping, or sharp-edged tools or heat sources. Always have work on the high-voltage system performed by a suitably qualified authorized Volkswagen dealer or authorized Volkswagen Service Facility approved for this work. Volkswagen recommends contacting an authorized Volkswagen dealer or authorized Volkswagen Service Facility.
- Never perform repair and maintenance procedures on orange high-voltage cables or high-voltage components.

⚠ DANGER

Any damage to the vehicle or high-voltage battery may result in the immediate or delayed escape of poisonous gases or liquids. The escaping gases may cause a fire. There is a risk of serious or fatal injuries.

- Do not breathe in the gases escaping from the high-voltage battery.
- Never touch liquids leaking from the high-voltage battery.
- If a fire breaks out, leave the danger zone with all vehicle occupants and contact the fire department.
- Always let the fire service and emergency responders know that your vehicle is equipped with a high-voltage battery.

⚠ WARNING

The high voltage in the electrical system may cause electric shocks and burns. This could result in serious or fatal injuries.

- Never short-circuit the electrical system. The 12 V vehicle battery could explode.
- Never touch the high-voltage components, the high-voltage battery or, in particular, the orange high-voltage cables when the vehicle is drive-ready or the vehicle's drive system is being switched on.

Preparing the vehicle for work in the hood space

Always perform the following activities in the specified sequence before all work in the hood space ⇒ ⚠:

1. Park the vehicle safely on level and stable ground ⇒ *Parking*.
2. Remove the remote control vehicle key from the vehicle and store it outside of the vehicle, so that the vehicle does not start accidentally.
3. Always keep other people away from the hood space.
4. Secure the vehicle against rolling away.

⚠ WARNING

If the steps described for working in the hood space are ignored, accidents may occur. Serious injuries may result.

- Always follow the tasks described and observe the general safety precautions.

Opening and closing the hood

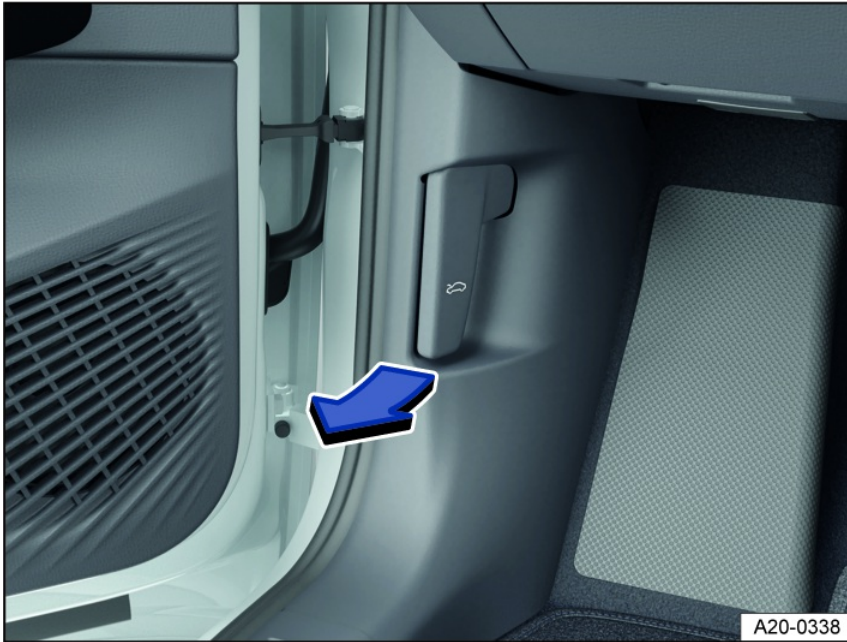

Fig. 156 In the driver's side footwell: Release lever for the hood (general example).

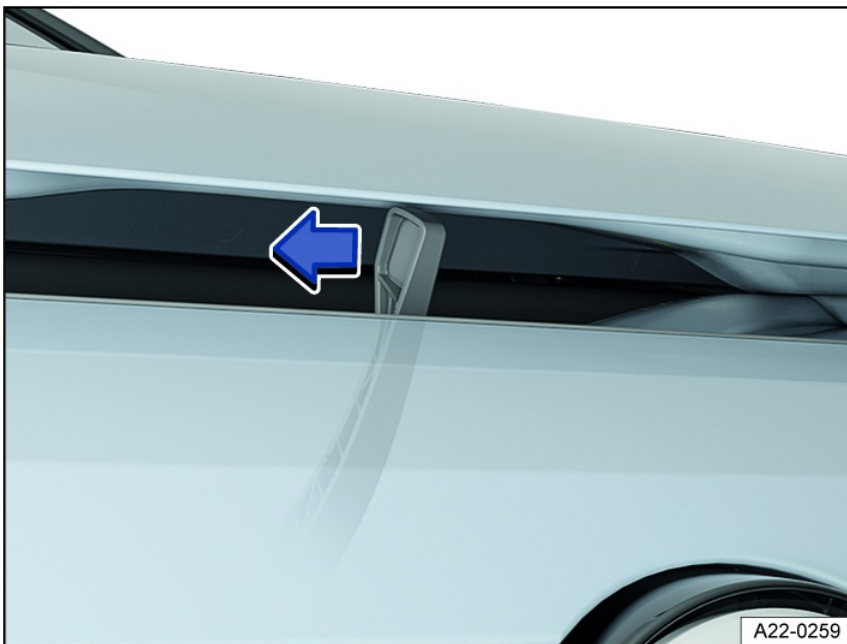

Fig. 157 On the hood: Opening lever.

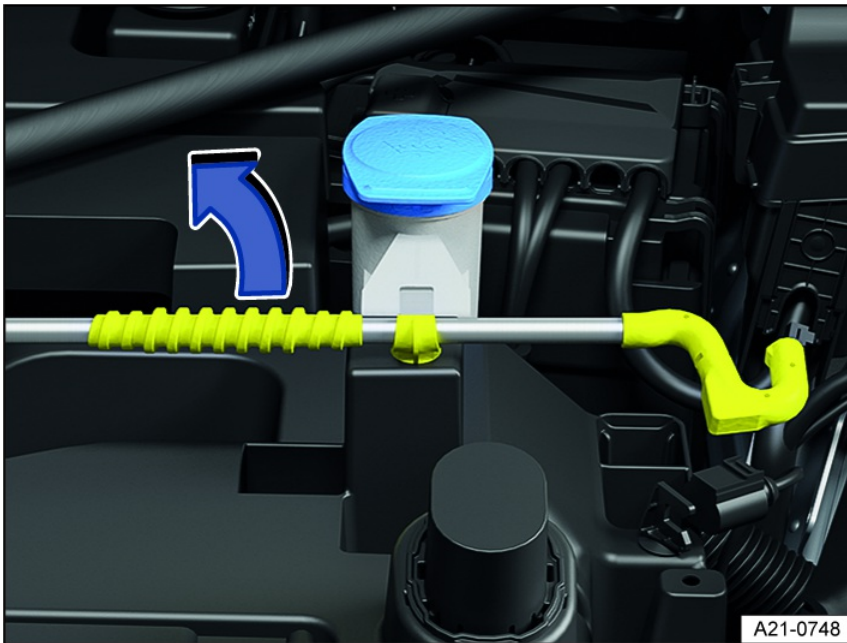

Fig. 158 In the hood space: Hood support in the bracket.

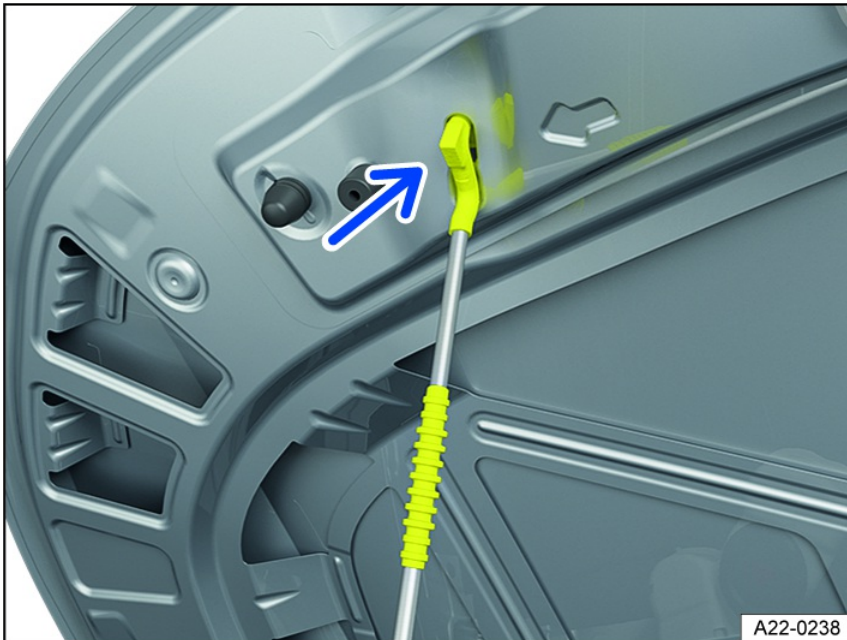



Fig. 159 On the engine hood: Hood support bracket (general example).

Opening the hood

1. Open the driver door and pull the release lever in the direction of the arrow [fig. 156](#). The hood will pop open due to spring force from the catch in the lock carrier ⇒ .
2. To open the hood fully, slightly lift the hood while pushing the actuating lever in the direction of the arrow [fig. 157](#).
3. Lift the hood support out of the bracket [fig. 158](#) in the direction of the arrow and hook it into the opening [fig. 159](#).

Closing the hood

1. Lift the hood slightly and hold it.
2. Unhook the hood support from the opening [fig. 159](#) and clip it back into the bracket [fig. 158](#).
3. Let the hood fall into the lock carrier catch from a height of approximately 20 cm (8 inches); do not press it down. When the hood is closed correctly, it will be flush with the surrounding sections of the vehicle body ⇒ .

If the hood is not closed correctly, lift the hood up and try to close it again.

If the hood is not correctly closed, an indicator will appear in the display of the Volkswagen Digital Cockpit. Once the hood is correctly closed, the indicator will turn off.

WARNING

If the hood is not closed correctly, it could open suddenly while driving and block the view through the windshield. Accidents and serious or fatal injuries could result.

- After closing the hood, check that the catch is engaged correctly in the lock carrier.
- If you realize when driving that the hood is not closed properly, park the vehicle safely and close the hood.

WARNING

Failing to take care when opening and closing the hood can result in serious injuries.

- Do not open or close the hood if any persons are in the closing range of the hood.

NOTICE

Opening and closing the hood incorrectly can cause damage to the hood or wiper arms.

- Only open the hood when wiper mode is switched off and with the windshield wipers folded in.
- Always fold the wiper arms against the windshield before driving.

Display

An image in the instrument cluster display indicates if the hood is open or has not closed correctly ⇒ .

Do not continue driving!

1. Stop the vehicle as soon as it is safe to do so.
2. If necessary, lift the hood and close it again.

The image is also displayed when the ignition is switched off, and it disappears several seconds after the doors are closed and the vehicle is locked.

WARNING

Disregarding warning notifications could lead to breakdowns while driving, accidents and serious or fatal injuries.

- Never ignore warning notifications.
- Stop the vehicle as soon as it is safe to do so.
- Do not continue driving and seek professional assistance if the warning light does not go out.

Operating fluids and operating equipment

All operating fluids and operating equipment, such as engine coolant, and vehicle batteries, are continuously being developed. Have fluids and operating equipment replaced by suitably qualified professionals. Volkswagen recommends contacting an authorized Volkswagen dealer or authorized Volkswagen Service Facility.

WARNING

Carrying out work on the 12 V vehicle electrical system may cause fires and serious or fatal injuries.

- Always disconnect the 12 V vehicle battery.
- Always have a fully-functioning, checked fire extinguisher nearby.

WARNING

Fluids may be poisonous. Improper use and storage may cause serious or fatal injuries.

- Only store fluids in their sealed original containers.
- Never use empty food cans, bottles, or other containers to store fluids, because someone could drink the fluids by mistake.
- Keep children away from all fluids and operating equipment.
- Always read and heed the information and warnings on the packaging for the fluids.
- When using products that emit harmful vapors, always work outdoors or in a well-ventilated area.

WARNING

Fluids and some materials in the hood space are highly flammable and may ignite on contact with hot surfaces, sparks, or naked flames. This can lead to a fire and cause accidents and serious or fatal injuries.

- Never smoke near the hood space.
- Never work near open flames or sparks.

- Never perform work near sources of heat, boilers, or other open flames.
- Never pour or spill fluids on the electric drivetrain.
- Always have a fully-functioning, checked fire extinguisher nearby.

NOTICE

The use of incorrect fluids can cause serious malfunctions and damage to the electric drivetrain.

- When filling or changing fluids, make sure the correct fluids are added to the corresponding reservoirs.

 Fluids leaking from the vehicle can cause environmental damage. Always check the ground under the vehicle for leaking fluids. If you see spots of fluid on the ground under the vehicle, have the vehicle checked by an authorized Volkswagen dealer or authorized Volkswagen Service Facility. Dispose of leaking fluids correctly. Volkswagen recommends contacting an authorized Volkswagen dealer or authorized Volkswagen Service Facility.

Washer fluid

General information



Fig. 160 In the hood space: Cap on the washer fluid reservoir (general example).



The windshield washer fluid reservoir is located in the hood space. The washer fluid reservoir is identified with the  symbol on the cap [fig. 160](#).

Check the washer fluid level regularly and fill if necessary.

Preparations

1. Prepare the vehicle for work in the hood space ⇒ [In the hood space](#).
2. Open the hood → page , [Opening and closing the hood](#).

Checking and refilling

1. Check if there is enough washer fluid in the reservoir.
2. To top it up, mix clean water with a suitable alcohol-based windshield cleaner. Follow the mixing instructions on the packaging of the windshield cleaner ⇒  ⇒ . There is a screen in the filler tube in the windshield washer fluid reservoir. The screen keeps large particles of contaminants from entering the washer nozzles when you refill the washer fluid ⇒ .
3. When the outside temperatures are cold, an anti-freeze agent should be added to the water so that it does not freeze. Follow the mixing instructions on the packaging of the anti-freeze agent.

 Do not use distilled water to fill the windshield washer fluid tank.

WARNING

Unsuitable additives in the windshield washer fluid can create an oily film on the vehicle windshield. This may reduce visibility and increase the risk of accidents and serious or fatal injuries.

- Never add coolant additive or similar unsuitable additives to the windshield washer fluid.

! NOTICE

Using a cleaning agent that contains acid may result in damage and cause the spray nozzles to malfunction.

- Never top up the windshield washer fluid tank using a cleaning agent that contains acid, e.g. vinegar-based cleaners.

! NOTICE

Mixing different windshield cleaners can cause the components to flocculate and the spray nozzles to clog.

- Only use suitable alcohol-based windshield cleaners.
- Never mix different windshield cleaners together.

! NOTICE

When you top up the windshield washer fluid, if you use a damaged screen or do not use a screen at all, dirt particles may get into the windshield washer fluid tank. The spray nozzles may become clogged.

- Take the screen out only to clean it.
- Replace a damaged or missing screen.

Engine coolant

Introduction

Only perform work on the engine cooling system if you are familiar with the necessary activities and the general safety precautions, and if the correct operating equipment, fluids and suitable tools are available. Work performed incorrectly can result in serious injuries ⇒ . Have all work performed by suitably qualified professionals if necessary. Volkswagen recommends contacting an authorized Volkswagen dealer or authorized Volkswagen Service Facility.

Information about warning and indicator lights can be found in the troubleshooting section at the end of the chapter ⇒ [Troubleshooting](#).

WARNING

Engine coolant is poisonous. Contact with coolant, especially swallowing coolant, may result in serious or fatal injuries.

- If you swallow coolant, seek urgent medical help.
- If you have health problems after working with coolant, seek medical help.
- Always store engine coolant out of the reach of children and only within the sealed original container.
- Never use empty food cans, bottles, or other containers to store engine coolant, because someone could drink the engine coolant by mistake.
- Avoid regular contact with coolant to prevent damage to your skin.
- Protect your skin, face, and particularly your eyes when working with coolant.
- Do not eat, drink, or smoke when working with coolant.
- Wash your skin with soap and water after working with coolant.

WARNING

In extremely low temperatures, the coolant can freeze and the vehicle could break down. This can cause the heating to stop working in the vehicle. Vehicle occupants could die of exposure if they do not have sufficient warm clothing.

- Make sure the coolant additive is always adjusted according to the ambient temperature.
- Only use coolant additive approved by the manufacturer.

 Coolant and coolant additives can pollute the environment. Catch any leaking operating fluids and dispose of them correctly according to environmental regulations.

Engine coolant specifications

 Please read the introductory information and heed the Warnings and Notice ⇒  and  **Safety precautions for working in the hood space**.

The cooling system is filled at the factory with a mixture of specially prepared water and at least 40% coolant additive G12evo (TL 744-L).

To protect the engine cooling system, there must always be at least a 40% proportion of coolant additive. If greater freeze protection is needed due to the climate, the proportion of coolant additive can be increased. However, the proportion of coolant additive must not exceed 55 %, because otherwise the freeze protection will be reduced and the cooling effect will be decreased.

The engine coolant additive can be recognized by its violet color. The mixture of water and coolant additive provides freeze protection down to -25 °C (-13 °F), protects the aluminum alloy parts of the cooling system from corrosion, prevents limescale deposits, and increases the boiling point of the coolant.

If the engine coolant is being topped up, a blend of distilled water and at least 40% of the G12evo engine coolant additive must be used to ensure optimum corrosion protection ⇒ ⚠.

⚠ CAUTION

In extremely low temperatures, the coolant can freeze and the vehicle could break down. This can cause the heating to stop working in the vehicle. Vehicle occupants could die of exposure if they do not have sufficient warm clothing.

- Make sure the coolant additive is always adjusted according to the ambient temperature.
- Only use coolant additive approved by the manufacturer.

⚠ NOTICE

The coloring of the engine coolant results from the mixture of the purple coolant additive and distilled water. If the fluid in the coolant expansion tank is not purple, but for example brown, the engine coolant has been mixed with another non-suitable coolant. Serious malfunctions or damage to the electric drivetrain and cooling system could occur.

- Only use coolant additive approved by the manufacturer.
- If the coolant turns brown, have it changed immediately by an authorized Volkswagen dealer or authorized Volkswagen Service Facility. Volkswagen recommends contacting an authorized Volkswagen dealer or authorized Volkswagen Service Facility.
- Never mix original Volkswagen coolant additives with coolant additives that are not approved by Volkswagen when topping up.

🌿 Engine coolant and coolant additives can harm the environment. Catch any leaking operating fluids and dispose of them correctly according to environmental regulations.

Checking and filling engine coolant

📖 Please read the introductory information and heed the Warnings and Notice ⇒ ⚠ and ⚠ *Safety precautions for working in the hood space.*

Preparations

1. Parking the vehicle on a level, secure surface.
2. Let the electric drive system cool down ⇒ ⚠.
3. Open the hood.

The coolant expansion tank is identified with the 🚫 red symbol on the cap *fig. 161*.



Fig. 161 In the hood space: Cap on the coolant expansion tank (general example).

⚠ WARNING

Escaping hot steam or hot coolant and hot components may cause serious burns.

- Never open the hood if you can see or hear steam or coolant escaping from the hood space.
- Always wait until you can no longer see or hear steam or engine coolant escaping from the hood space.

⚠ WARNING

The motor cooling system is under pressure when the electric motor is hot. If the cover is opened carelessly, coolant may spray out and cause serious burns or fatal injuries.

- Never open the cap on the coolant expansion tank when the electric drivetrain is hot.
- Always protect your face, hands and arms from hot coolant or steam with a large, thick cloth if you need to open the cover of the coolant tank.
- Slowly and very carefully turn the cap on the coolant expansion tank counterclockwise while pressing down lightly on the cap.

Checking the coolant level



Fig. 162 In the hood space: markings on the engine coolant expansion tank (general example).

When new vehicles are delivered or after repairs to the cooling system, the coolant level may be above the marked area. This is normal. The coolant does not need to be extracted.

The coolant level cannot be checked exactly for every model, because the view of the fluid level in the coolant expansion tank may be obstructed. If you cannot read off the engine coolant level accurately, contact a suitably qualified professional. Volkswagen recommends contacting an authorized Volkswagen dealer or authorized Volkswagen Service Facility.

1. When the electric motor is cold, check the coolant level using the markings on the side of the coolant expansion tank [fig. 162](#). The coolant level must be between the markings.
2. If the fluid level in the coolant expansion tank is below the minimum mark ("min"), have coolant added. When the electric drivetrain is warm, the engine coolant level may be slightly above the upper marking.
3. If no coolant is visible in the coolant expansion tank, do not add coolant ⇒

Filling the coolant

1. Carefully unscrew the cap ⇒ .
2. Only add new coolant that conforms to the Volkswagen specification ⇒ [Engine coolant specifications](#).

If there is no engine coolant available that conforms to the required specification, initially only top up with distilled water. Then have the correct mixture ratio using the specified coolant additive restored as soon as possible by an authorized Volkswagen dealer or authorized Volkswagen Service Facility. Volkswagen recommends contacting an authorized Volkswagen dealer or authorized Volkswagen Service Facility ⇒ .

3. Top up the engine coolant to the upper fill level marker. After topping up the engine coolant, the coolant level must be between the markings on the coolant expansion tank [fig. 162](#).
4. Install the cap securely.
5. Check the coolant level after one day. If the level of the engine coolant tank drops below the "min" minimum marking again, contact an authorized Volkswagen

dealer or authorized Volkswagen Service Facility and have the cooling system checked. Volkswagen recommends contacting an authorized Volkswagen dealer or authorized Volkswagen Service Facility.

6. If there is no engine coolant available that conforms to the specification, do not use any other engine coolant additive in an emergency ⇒ .

NOTICE

Coolant expands when it heats up. If coolant is topped up above the marked level, excess coolant may leak out and cause damage to the vehicle.

- Do not refill the system with engine coolant above the upper edge of the marked area of the engine coolant tank.

NOTICE

If there is no more engine coolant in the coolant expansion tank, air can get into the cooling system. This could result in damage to the electric drivetrain.

- Do not continue driving.
- Do not top up the coolant.
- See an authorized Volkswagen dealer or authorized Volkswagen Service Facility for assistance.

NOTICE

The chemical components contained in water that is not distilled can cause considerable corrosion damage in the engine. This can cause electric drivetrain malfunctions.

- Only use distilled water for refilling the system!
- If you have added water that is not distilled, have the fluid in the cooling system changed completely by an authorized Volkswagen dealer or authorized Volkswagen Service Facility. Volkswagen recommends contacting an authorized Volkswagen dealer or authorized Volkswagen Service Facility.

NOTICE

The use of incorrect fluids can cause serious malfunctions and damage to the electric drivetrain.

- When filling or changing fluids, make sure the correct fluids are added to the corresponding reservoirs.

Troubleshooting

 Please read the introductory information and heed the Warnings and Notice ⇒  and  *Safety precautions for working in the hood space.*

Engine coolant

The red warning light blinks. The coolant temperature is too high or the coolant level is too low.

 Do not continue driving! This could result in damage to the electric drivetrain.

1. Stop the vehicle as soon as it is safe to do so ⇒ *Parking.*
2. End drive-ready mode.
3. Let the electric drive system cool down.

Engine cooling system

1. Check the engine coolant level ⇒ *Checking and filling engine coolant.*
2. If the warning light does not go out even though the coolant is at the correct level, do not drive any further; deactivate the vehicle's drive system immediately.
3. Contact an authorized Volkswagen dealer or authorized Volkswagen Service Facility for assistance.

together with High-voltage coolant system malfunction

The warning lights blink red.

 Do not continue driving!

1. Stop the vehicle immediately as soon as it is safe to do so ⇒ *Parking.*
2. End drive-ready mode.
3. Contact an authorized Volkswagen dealer or authorized Volkswagen Service Facility immediately for assistance.

Brake fluid

Introduction

Brake fluid absorbs moisture from the air over the course of time. Too much water in the brake fluid causes damage to the brake system. Water lowers the boiling

point of the brake fluid. If the water content in the brake fluid is too high, vapor lock may form in the brake system during heavy braking and full braking. Vapor lock reduces the braking efficiency, increases the braking distance considerably, and can lead to a total failure of the brake system. Your own safety and the safety of others on the road depends on your brake system functioning correctly at all times.

WARNING

Brake fluid is poisonous. Contact with brake fluid, especially swallowing brake fluid, may result in serious or fatal injuries.

- If you swallow brake fluid, seek urgent medical help.
- If you have health problems after working with brake fluid, seek medical help.
- Always store brake fluid out of the reach of children and only within the sealed original container.
- Never use empty food cans, bottles, or other containers to store brake fluid, because someone could drink the brake fluid by mistake.
- Avoid regular contact with brake fluid to prevent damage to your skin.
- Protect your skin, face, and particularly your eyes when working with brake fluid.
- Do not eat, drink, or smoke when working with brake fluid.
- Wash your skin with soap and water after working with brake fluid.



NOTICE

Spilled or leaking brake fluid will damage the vehicle's surfaces. The vehicle's paint, plastic parts, and tires may be damaged.

- Immediately wipe up any spilled or leaking brake fluid that comes into contact with vehicle components.
- Then rinse all vehicle parts with plenty of water.

 Brake fluid can pollute the environment. Collect spilled brake fluid and dispose of it correctly.

Brake fluid specifications

 Please read the introductory information and heed the Warnings and Notice  and  Safety precautions for working in the hood space. Volkswagen has developed a special brake fluid that is optimized for the vehicle's brake system. For optimum performance of the brake system, Volkswagen recommends only using brake fluid that complies with the VW standard 501 14.

Before using brake fluid, check that the brake fluid specification on the bottle matches the vehicle requirements.

Brake fluid that complies with the VW standard 501 14 can be obtained from an authorized Volkswagen dealer or authorized Volkswagen Service Facility.

If brake fluid that meets this specification is not available and another high-quality brake fluid must therefore be used, brake fluid that complies with the specification DIN ISO 4925 or the US Standard FMVSS 116 DOT 4 CLASS 6 can be used.

Not all brake fluids that comply with the requirements of DIN ISO 4925 or US Standard FMVSS 116 DOT 4 CLASS 6 have the same chemical composition. Some of these brake fluids can contain chemicals that can destroy or damage components of the vehicle brake system over time.

To help ensure that the brake system functions correctly over the long term, Volkswagen recommends using a brake fluid that expressly conforms to the VW standard 501 14.

Brake fluid that complies with the VW standard 501 14 meets the requirements of DIN ISO 4925 or the US Standard FMVSS 116 DOT 4 CLASS 6.

Checking the Brake Fluid

 Please read the introductory information and heed the Warnings and Notice  and  Safety precautions for working in the hood space.

Preparations

1. Parking the vehicle on a level, secure surface.
2. Open the hood.

Checking the Brake Fluid Level

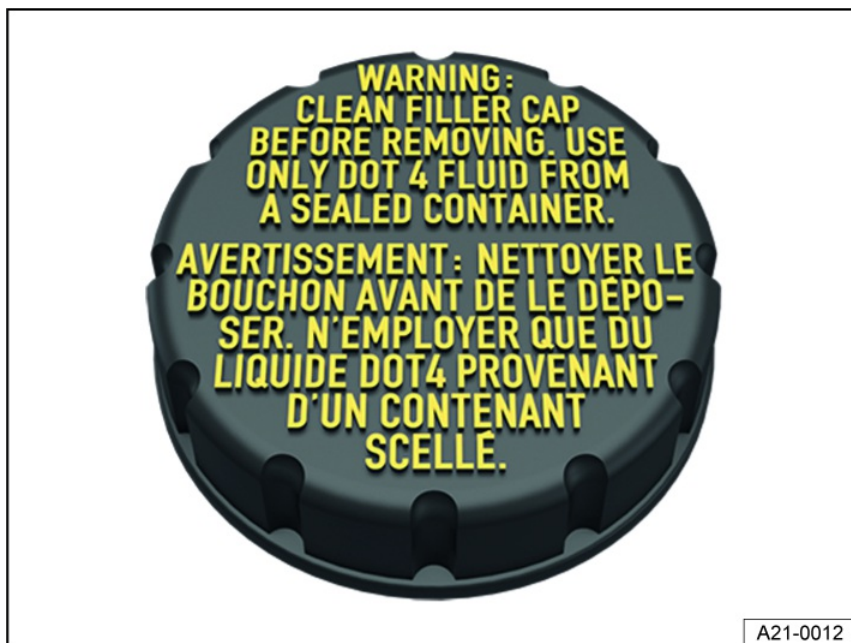

Fig. 163 In the hood space: Cap on the brake fluid reservoir.

The brake fluid reservoir can be recognized by its cap *fig. 163*.

The brake fluid level cannot be checked precisely on all models because the hood or engine components may obstruct the view of the fluid level in the reservoir. If you cannot read the brake fluid level clearly, see an authorized Volkswagen dealer or authorized Volkswagen Service Facility for assistance. Volkswagen recommends contacting an authorized Volkswagen dealer or authorized Volkswagen Service Facility.

The brake fluid level must always be between the MIN and MAX markings on the brake fluid reservoir ⇒ ⚠.

The brake fluid level decreases slightly when the vehicle is being used as the brake pads wear and the brakes automatically adjust themselves.

⚠ WARNING

A low brake fluid level or unsuitable brake fluid may cause the brakes to fail or may reduce braking efficiency. Accidents and serious or fatal injuries could result.

- Have the brake system and brake fluid level checked regularly.
- Be sure to use the correct brake fluid.
- Only use brake fluid that expressly complies with the VW standard 501 14.
- If brake fluid that complies with the VW standard 501 14 is not available, in exceptions only use a high-quality brake fluid that complies with DIN ISO 4925 CLASS 6 or US standard FMVSS 116 DOT 4.

Changing brake fluid

Have the brake fluid changed regularly. An authorized Volkswagen dealer or authorized Volkswagen Service Facility can provide information about the interval for changing the vehicle brake fluid. Only have brake fluid added that meets the required specifications. Volkswagen recommends contacting an authorized Volkswagen dealer or authorized Volkswagen Service Facility.

⚠ WARNING

Vapor lock may occur in old brake fluid due to absorbed moisture during hard braking, reducing braking efficiency and potentially causing total brake failure. Accidents and serious or fatal injuries could result.

- Have the brake fluid changed regularly.
- Only have new brake fluid added.

Troubleshooting

📖 Please read the introductory information and heed the Warnings and Notice ⇒ ⚠ and ⚠ Safety precautions for working in the hood space.

BRAKE Brake fluid level

The red warning light turns on. The brake fluid level is too low.

🛑 Do not continue driving! This could result in the brake failing.

1. Stop the vehicle immediately as soon as it is safe to do so ⇒ *Parking*.
2. Check the brake fluid level.

3. If the brake fluid level is too low, contact an authorized Volkswagen dealer or authorized Volkswagen Service Facility.

12 V vehicle battery

Introduction

The 12 V vehicle battery is a component of the electrical system and supplies vehicle safety systems with energy if there is high-voltage system malfunction. During maintenance procedures, the 12 V vehicle battery is checked and replaced if necessary.







You may only perform procedures on the electrical system yourself if you are familiar with the necessary activities and the general safety precautions, and if the correct operating equipment and fluids and suitable tools are available. Work performed incorrectly can result in serious injuries → . Have all work performed by suitably qualified professionals. Volkswagen recommends contacting an authorized Volkswagen dealer or authorized Volkswagen Service Facility.

Information about warning and indicator lights can be found in the troubleshooting section at the end of the chapter → [Troubleshooting](#).

Battery switch-off in an accident with triggering of the airbag

In vehicles with a 12 V vehicle battery in their vehicle interior or luggage compartment, the electrical connection to the 12 V vehicle battery is pyrotechnically disconnected in an accident with airbag deployment. This prevents a short circuit. For more information on the installation location of the vehicle battery, refer to section → page , [Checking the 12 V vehicle battery acid level](#) .

Detailed warnings for the 12 V vehicle battery

 Always wear eye protection.  Battery acid is highly corrosive. Always wear protective gloves and eye protection.  Fire, sparks, open flame, and smoking are forbidden.  A highly explosive mixture of gases forms when charging the 12 V vehicle battery.  Always keep children away from battery acid and the 12 V vehicle battery.  Always heed the Owner's Manual.

WARNING

Performing work on the 12 V vehicle battery and the electrical system can cause serious injuries, fires, or electric shocks. This could result in serious injuries.

- Always read and follow the warning information on the 12 V vehicle battery.
- Before performing any work on the 12 V vehicle battery, switch off the ignition and all electrical equipment and disconnect the 12 V battery negative cable.
- Always keep children away from battery electrolyte and the 12 V vehicle battery.
- When handling 12 V vehicle batteries, always protect your hands, arms, and face from spraying battery acid.
- Always wear eye protection and safety gloves.
- Never short circuit the battery terminals.

WARNING

When work is carried out on the 12 V vehicle battery, a highly explosive, flammable gas mixture builds up. Sparks could form and ignite the flammable gas that is released by the 12 V vehicle battery. This can result in serious injury or death.

- Always keep fires, sparks, open flames, and lit cigarettes far away from the 12 V vehicle battery.
- Avoid creating sparks when working with wires and electrical equipment or when discharging static electricity.

WARNING

A drained 12 V vehicle battery can freeze at temperatures around 0 °C (+32 °F). Acid may leak out of 12 V vehicle batteries that have frozen and thawed again and cause damage to the vehicle in the long run.

- Never charge a frozen or thawed 12 V vehicle battery.
- Always replace the 12 V vehicle battery if it freezes.

WARNING

California Proposition 65 Warning.

- This product can expose you to chemicals including lead and lead components, which are known to the State of California to cause cancer and birth defects or other reproductive harm. For more information go to <https://www.P65Warnings.ca.gov>.

NOTICE

UV rays can damage the battery housing.

- Do not expose the 12 V vehicle battery to direct sunlight for a long period of time.

NOTICE

The 12 V vehicle battery could freeze and be destroyed.

- Protect the 12 V vehicle battery against freezing temperatures if the vehicle is parked for long periods of time.

 After establishing the drive-ready mode when the 12 V vehicle battery is severely drained or replaced or after jump-starting it, the system settings (time, date, personal convenience settings, and programming) and user profiles may be changed or deleted. Check and correct the settings after the 12 V vehicle battery is sufficiently recharged.

Checking the 12 V vehicle battery acid level

 Please read the introductory information and heed the Warnings and Notice  and  Safety precautions for working in the hood space.

Check the acid level of the 12 V vehicle battery regularly if mileage is high, in countries with warm climates, or if the 12 V vehicle battery is old. Otherwise, the 12 V vehicle battery is maintenance-free.

12 V vehicle battery location

The 12 V vehicle battery is located in the hood space.

Checking the battery acid level

In order to check the battery acid level of a 12 V vehicle battery, you must remove the main fuse box on the 12 V vehicle battery. An additional tool that is not available in the vehicle tool kit is required to do this.

Always have the acid level of the 12 V vehicle battery checked by an authorized Volkswagen dealer or authorized Volkswagen Service Facility. Volkswagen recommends contacting an authorized Volkswagen dealer or authorized Volkswagen Service Facility.

Charging, replacing, disconnecting, or connecting the 12 V vehicle battery

 Please read the introductory information and heed the Warnings and Notice  and  Safety precautions for working in the hood space.

If you suspect that the 12 V vehicle battery is damaged or malfunctioning, see suitably qualified professionals to have the 12 V vehicle battery checked. Volkswagen recommends contacting an authorized Volkswagen dealer or authorized Volkswagen Service Facility.

Charging the 12 V vehicle battery

The 12 V vehicle battery should be charged by suitably qualified professionals because the 12 V vehicle battery that is installed at the factory requires a charging process where the voltage is limited . Volkswagen recommends contacting an authorized Volkswagen dealer or authorized Volkswagen Service Facility.

Replacing the 12 V vehicle battery

The 12 V vehicle battery is designed to fit the location where it is installed and is equipped with safety features. If a 12 V vehicle battery needs to be replaced, have the replacement part fitted by qualified professionals. Volkswagen recommends contacting an authorized Volkswagen dealer or authorized Volkswagen Service Facility. Check with qualified professionals to find out the component information regarding size and the required maintenance, performance, and safety features. They must possess the necessary technical documentation and equipment. Volkswagen recommends contacting an authorized Volkswagen dealer or authorized Volkswagen Service Facility. The vent opening on the 12 V vehicle battery must always be located on the negative terminal side. The vent opening on the positive terminal side must always be sealed .

Only use a maintenance-free 12 V vehicle battery that conforms to the TL 825 06 and VW 7 50 73 standards. These standards must be from October 2014 or later.

Always have the 12 V vehicle battery replaced by qualified professionals because the vehicle electronics must be adapted as part of the replacement. In addition, the battery parameters for functional safety can only be determined with the OEM battery. Only qualified professionals have the necessary equipment to perform the adaptation and have access to the correct replacement batteries. Using unsuitable batteries invalidates the operating license.

Disconnecting the 12 V vehicle battery

If the 12 V vehicle battery must be disconnected from the vehicle electrical system, note the following:



1. Switch off all electrical consumers.
2. Disconnect the negative cable first, and then the positive cable .

Connecting the 12 V vehicle battery

If the 12 V vehicle battery must be connected to the vehicle electrical system, note the following:

1. Switch off all electrical consumers.
2. Connect the positive cable first, and then the negative cable .

Various indicator lights may turn on after connecting the 12 V vehicle battery and switching the ignition on. They will turn off after driving a short distance at a speed of approximately 15 km/h to 20 km/h (approximately 10 mph to 12 mph). If the indicator lights light up and remain on, contact an authorized Volkswagen dealer or authorized Volkswagen Service Facility and have the vehicle checked. Volkswagen recommends contacting an authorized Volkswagen dealer or authorized Volkswagen Service Facility.

If the 12 V vehicle battery was disconnected for a long period of time, the next scheduled maintenance may not display correctly or it may not be calculated correctly  *Service display*. Follow the maximum permissible maintenance interval  *Maintenance*.

If the ignition cannot be switched on after connecting the 12 V vehicle battery, carry out the following activities:

1. Lock and unlock the vehicle from the outside.
2. Try to switch the ignition on again.
3. If the ignition will not switch on, see an authorized Volkswagen dealer or authorized Volkswagen Service Facility for assistance.

Automatic equipment deactivation

If the parking light is switched on when parking for a very long time when the vehicle is not drive-ready, the intelligent power management cannot always prevent the 12 V vehicle battery from being drained.

If the 12 V vehicle battery is under a heavy load, the intelligent power management will automatically begin certain measures to prevent the 12 V vehicle battery from draining.

- If necessary, equipment that uses a lot of power will have its performance limited or will be switched off.

12 V Vehicle Battery Draining

If the battery is drained, it may not be possible to activate the vehicle's drive system. The 12 V vehicle battery will be drained in the following situations:

- If the vehicle is parked for long periods of time without ensuring that the vehicle is drive-ready.
- If electrical equipment is used when the vehicle is not in drive-ready mode.

⚠ WARNING

Use of a 12 V vehicle battery that does not have identical specifications and dimensions to the 12 V vehicle battery that was installed at the factory may cause short circuits or fire. This could result in serious or fatal injuries.

- Always use a maintenance-free and leak-proof 12 V vehicle battery that has the same specifications and dimensions as the 12 V vehicle battery that was installed at the factory.

⚠ WARNING

Fitting 12 V vehicle batteries incorrectly may cause short circuits or fire. This could result in serious or fatal injuries.

- Always attach the 12 V vehicle battery to the attachment points provided in the vehicle.
- Replace all covers that are required for the vehicle back on the battery.

⚠ WARNING

A highly explosive mixture of hydrogen gas can form when charging the 12 V vehicle battery. Sparks or naked flames could ignite the gas mixture. Serious burns may result.

- Only charge 12 V vehicle batteries in well-ventilated areas.
- Keep sparks and naked flames away from the 12 V vehicle battery.

⚠ WARNING

A drained 12 V vehicle battery can freeze at temperatures around 0 °C (+32 °F). Acid may leak out of 12 V vehicle batteries that have frozen and thawed again and cause damage to the vehicle in the long run.

- Never charge a frozen or thawed 12 V vehicle battery.
- Always replace the 12 V vehicle battery if it freezes.

⚠ WARNING

If the degassing tube is not attached to the 12 V vehicle battery correctly, the highly explosive gas mixture that builds up when the vehicle is running may enter the vehicle interior. This oxyhydrogen gas can ignite and cause serious or fatal injuries.

- For vehicles with the 12 V vehicle battery in the vehicle interior or luggage compartment, ensure that the degassing hose is connected to the 12 V vehicle battery correctly. The degassing hose must always be connected to the negative terminal side of the 12-volt vehicle battery.
- Always ensure that the opening on the positive terminal side of the 12 V vehicle battery is capped.

⚠ CAUTION

Cables that are connected incorrectly can cause a short circuit. This could damage the on-board electronics and result in serious injuries.

- Connect the positive cable first and then the negative cable.

NOTICE

If the 12 V vehicle battery is connected or disconnected when the ignition is switched on or the vehicle is drive-ready, this could damage the electrical system or electronic components, resulting in electrical malfunctions.

- Never connect or disconnect the 12 V vehicle battery when the ignition or the vehicle's drive system is switched on.

NOTICE

If accessories that provide power for charging the 12 V vehicle battery are connected to the 12 V socket, this could damage the electrical system or electronic components, resulting in electrical malfunctions.

- Never connect accessories that provide power, such as solar panels or battery chargers, to the 12 V socket in order to charge the 12 V vehicle battery.

 12 V vehicle batteries can contain toxic substances such as sulfuric acid and lead. Dispose of 12 V vehicle batteries correctly.

 Battery acid can pollute the environment. Collect spilled battery acid and dispose of it correctly.

Troubleshooting

 Please read the introductory information and heed the Warnings and Notice ⇒  and  *Safety precautions for working in the hood space.*

12-volt power supply

The red warning light turns on. A message is shown in the instrument cluster display.

 Do not continue driving! Possible failure of the electrical system.

1. Stop the vehicle immediately and park it safely.
2. Turn off electrical equipment that is not needed.
3. End drive-ready mode.
4. Contact an authorized Volkswagen dealer or authorized Volkswagen Service Facility for assistance.

12-volt power supply

The yellow indicator light turns on. A message is shown in the instrument cluster display.

Messages about the battery charge level of the 12 V vehicle battery.

1. Switch on the ignition so that the 12 V vehicle battery can be recharged.
Or: Charge the 12 V vehicle battery by charging the high-voltage battery.
2. If the message about the battery charge level of the 12 V vehicle battery does not turn off after a few minutes despite the measures having been taken, then contact an authorized Volkswagen dealer or authorized Volkswagen Service Facility.

Messages about the 12 V power supply.

1. Contact an authorized Volkswagen dealer or authorized Volkswagen Service Facility for assistance.

Wheels and tires

Introduction

Tires are the part of the vehicle that are under the most demand yet are the most underestimated. Tires are extremely important, because the small running surface on the tires is the only point of contact that the vehicle has with the road.

The tire and rim combinations approved by Volkswagen are specifically designed for each other.

The service life of the tire depends on the tire pressure, the driving style, the way the tires are handled, and correct mounting of the tire.

Rims, tires and wheel bolts

Rims, tires, and wheel bolts are determined based on the vehicle model. Whenever another rim is installed, the wheel bolts to be used must have the correct length and bolt head shape. This ensures that the brakes can work correctly and that the vehicle drives smoothly and safely. For technical reasons, standard rims from other vehicles cannot be used. Under certain circumstances, this may even apply to rims for the same vehicle model. You must consult a suitably qualified professional to replace rim/tire combinations. Volkswagen recommends contacting an authorized Volkswagen dealer or authorized Volkswagen Service Facility.

The correct wheel bolts must always be used for each vehicle model, and these bolts must always be tightened to the correct torque → [Monitoring the tightening torque](#).

WARNING

Handling wheels and tires incorrectly can reduce driving safety and cause serious accidents and fatal injuries.

- Regularly check the tire pressure when the tires are cold and always maintain the specified pressure → [Checking the tire pressure](#). If the tire pressure is too low, the tire can heat up so much while driving that the tread separates or the tire ruptures.
- Check the tires regularly for damage and wear.
- Never exceed the maximum permissible speed and tire load specified for the tires fitted to your vehicle.
- For all four wheels, use only radial tires of the same design, size (rolling circumference), and tread pattern. Exceptions → [Replacing tires](#)
- If there are unusual vibrations or if the vehicle pulls to one side while driving, stop immediately and check the wheels and tires for damage.
- Never loosen the bolts on rims with a bolted rim ring.

WARNING

New tires or tires that are old, worn, or damaged cannot provide the maximum vehicle control and braking effect.

This can cause accidents and fatal injuries.

- Break in new tires because they have reduced traction and braking efficiency when they are new. Therefore drive carefully for the first 600 km (370 miles).
- Never drive with tires that are worn or damaged, e.g. punctured, cut, cracked, or bulging.
- If there are unusual vibrations or if the vehicle pulls to one side while driving, stop immediately and check the wheels and tires for damage.
- Do not use any wheels or tires if you do not know how they have been used in the past. Used wheels and tires could be damaged, even if there is no visible damage.
- Only use tires that are more than six years old if absolutely necessary and drive with extreme caution if doing so, even if the tires have never been used.
- Replace worn or damaged tires immediately.

WARNING

If the wheel bolts are not tightened enough to meet the specification, the wheel bolts and the wheel could come loose while driving. Exceeding the tightening specification could damage the wheel bolts and threads.

Wheel bolts that are tightened incorrectly or missing could cause you to lose control of the vehicle and lead to serious accidents and fatal injuries.

- Always tighten the wheel bolts to the correct tightening torque. If you do not have a torque wrench, tighten the wheel bolts with the lug wrench and then have the tightening torque checked as soon as possible by suitably qualified professionals. Volkswagen recommends contacting an authorized Volkswagen dealer or authorized Volkswagen Service Facility.
- Never drive with missing or loose wheel bolts.
- Always use wheel bolts that are correct for the rim and the vehicle model.
- Never grease or oil the wheel bolts and the threads in the wheel hub. Even when tightened to the specification, the wheel bolts could become loose while driving.
- Ensure the wheel bolts and threads in the wheel hubs are clean, easy to move and free of oil and grease.
- Never loosen the bolts on rims with a bolted rim ring.

WARNING

Improper installation of the tires on the rim can result in damage to the rim and cause tires to suddenly lose air or go flat while driving.

This can cause accidents and fatal injuries.

- Always have tires installed on the rim by an authorized Volkswagen dealer or authorized Volkswagen Service Facility. Volkswagen recommends contacting an authorized Volkswagen dealer or authorized Volkswagen Service Facility.

Taking care of wheels and tires

Handling tires

Preventing damage to the tires

- Always drive over curbs and other low obstacles slowly and at a right-angle so that both front wheels come into contact with the obstacle at the same time.
- Check the tire pressure regularly.
- Check tires regularly for damage, e.g. punctures.
- Never exceed the load index and maximum speed of the tire ⇒ [Tire labeling and tire classifications](#).
- Have damaged or worn rims replaced immediately ⇒ [Troubleshooting](#).
- Protect tires from coming into contact with corrosive materials such as grease, oil, gasoline, and brake fluid ⇒ .
- Replace missing dust caps on the valves immediately.
- Remove any objects provided they have not punctured the inside of the tire ⇒ [Troubleshooting](#).
- Pay attention to all warnings issued by the Tire Pressure Monitoring System ⇒ [Troubleshooting the Tire Pressure Monitoring System](#).

WARNING

Corrosive fluids and materials can cause visible and invisible damage to the tires, which can cause the tires to fail.

This can cause accidents and fatal injuries.

- Always keep chemicals, oils, grease, fuel, brake fluid, and other corrosive materials away from the tires.

Storing tires

- Only store tires in a cool, dry location that is as dark as possible.
- Do not stand tires that are mounted on rims up vertically.
- Protect tires that are not mounted on rims from dirt with suitable covers and store them standing on the tread surface.

Tires that are more than six years old

Tires age due to physical and chemical processes that affect their function. Tires that have been stored and unused for long periods of time age more quickly than tires that are used continuously.

Volkswagen recommends replacing tires that are more than six years old with new tires. This even applies to tires that may appear to be usable and whose tread depth is still greater than the minimum requirement ⇒ .

Winter and all season tires lose their characteristics to a large extent due to aging, regardless of the remaining tread depth.

The age of the tire can be determined based on the production date ⇒ [Tire labeling and tire classifications](#).

WARNING

Old tires can suddenly lose air or rupture, particularly at high speeds.

This can cause accidents and fatal injuries.

- Only use tires that are more than six years old if absolutely necessary and drive with extreme caution if doing so, even if the tires have never been used.

New tires

- Drive particularly carefully during the first 600 km (370 mi) with new tires because they must be broken in. Tires that have not been broken in yet have reduced gripping abilities and braking efficiency ⇒ .
- For all wheels, use only radial tires of the same design, size (rolling circumference), and tread pattern. Exceptions when replacing wheels are different tire and rim sizes on the front and rear axle.
- The tread depth of new tires may vary between tire models and manufacturers due to different design features and tread designs.

⚠ WARNING

New tires must be broken in because they have reduced traction and braking efficiency when they are new.

This could cause you to lose control of the vehicle and lead to serious accidents and fatal injuries.

- Break in new tires. Drive carefully for the first 600 km (370 miles).

 **The size specifications for new tires may vary significantly from the actual tire dimensions for different tire brands.**

Replacing tires

- At the factory, the vehicle is equipped by Volkswagen with genuine tires designed to reduce the rolling resistance as much as possible. Volkswagen Genuine tires are marked with the \oplus symbol. The specified fuel economy and range can only be achieved using these tires. When purchasing new tires, always make sure the tires are optimized for rolling resistance \Rightarrow [Eco tips](#).
- Before buying new reduced rolling resistance tires, seek advice from an authorized Volkswagen dealer or authorized Volkswagen Service Facility. Volkswagen recommends contacting an authorized Volkswagen dealer or authorized Volkswagen Service Facility.
- At a minimum, replace both tires on a single axle.
- Only replace old tires with tires that have been approved by Volkswagen for your vehicle model.
- Never use tires whose size exceeds the measurement of tires that are approved by Volkswagen \Rightarrow .

Recalibrating the Tire Pressure Monitoring System

The Tire Pressure Monitoring System must be recalibrated each time one or more wheels is replaced \Rightarrow [How the Tire Pressure Monitoring System Works](#).

This also applies if the tires are rotated, for example from front to back. Exceptions when replacing wheels are different tire and rim sizes on the front and rear axle.

⚠ WARNING

Tires must have enough clearance from vehicle components. If there is not enough clearance, tires could rub against components of the suspension, the body, and the brake lines.

This may cause the brake system to fail, the tread to separate, and the tire to rupture, resulting in serious accidents and fatal injuries.

- Only use tires with dimensions that do not exceed the dimensions of the tire brands approved by Volkswagen and that do not rub against other components of the vehicle.

! NOTICE

Driving over potholes and curbs can cause the tires to become deformed.

Damage to the tires and rims can result.

- Avoid strong impacts and drive around obstacles where possible.

! NOTICE

The valves may be damaged by dirt.

- Never drive without caps on the valves.

! NOTICE

The valves can be damaged when replacing wheels.

- Do not let wheels that you have removed fall on the rim.

 Always dispose of old tires correctly and according to regulations.

 **If the spare wheel is different from the regular vehicle wheels, e.g. in the case of winter tires or a temporary spare wheel, only use the spare wheel temporarily and in the event of a breakdown, and drive especially carefully. Replace the compact spare wheel with a regular wheel as soon as possible.**

 **Using tires approved by Volkswagen ensures that the dimensions will fit correctly on your vehicle. If other tires are used, the seller must provide a certificate from the tire manufacturer stating that the tires are suitable for the vehicle. Keep the certificate stored safely in the vehicle.**

Handling rims

Preventing damage to the rims

- Missing hubcaps can cause damage to the rims and wheel bolts.

Always install missing hubcaps before driving.

- Always drive over curbs and other low obstacles slowly and at a right-angle so that both front wheels come into contact with the obstacle at the same time.
- Replace missing dust caps on the valves immediately.
- Check the tire pressure regularly.

Rims with bolted rim ring or accent elements

Rims with a bolted rim ring or accent element consist of multiple pieces. These pieces are connected together with special bolts. Damaged rims must be replaced and may only be repaired by an authorized Volkswagen dealer or authorized Volkswagen Service Facility. Volkswagen recommends contacting an authorized Volkswagen dealer or authorized Volkswagen Service Facility.

Rim identification

In some countries, new rims must include information about certain properties. The following information may be on the rim:

- Seal of conformity
- Rim size
- Manufacturer or brand name
- Production date (month/year)
- Country of origin
- Serial number
- Raw material batch number
- Commodity code

WARNING

Using unsuitable or damaged rims can impair driving safety and cause accidents and serious injuries.

- Only use rims permitted for the vehicle.
- Check the rims regularly for damage and replace them if necessary.

WARNING

Loosening and tightening bolts incorrectly on rims with bolted rim rings can cause severe accidents and death.

- Never loosen the bolts on rims with a bolted rim ring.
- Have all procedures on rims with bolted rim rings performed by an authorized Volkswagen dealer or authorized Volkswagen Service Facility. Volkswagen recommends contacting an authorized Volkswagen dealer or authorized Volkswagen Service Facility.

Maintaining wheels and tires

Checking the tire pressure

- Check the tire pressure at least once a month.
- Check the tire pressure only when tires are cold. The specified tire pressure only applies to a cold tire. The tire pressure on warm tires is higher than on cold tires. Therefore, never release air from a warm tire to adjust the tire pressure.
- Always adjust the tire pressures to the vehicle load ⇒ .
- After adjusting tire pressures, always screw the caps on the valves and note the information about the Tire Pressure Monitoring System (TPMS).
- Always use the tire pressures specified on the label. Never exceed the maximum tire pressure specified on the side of the tire.

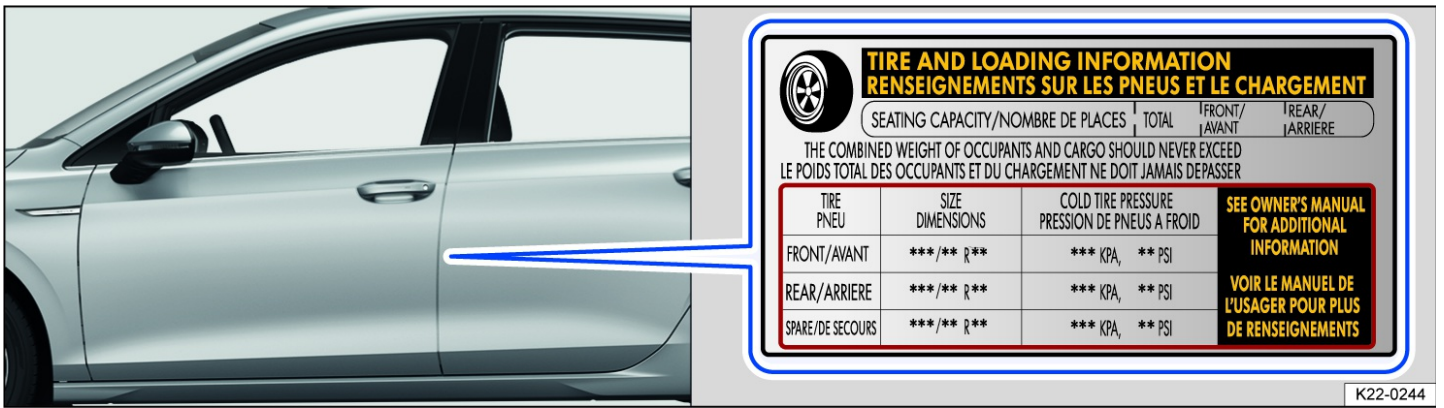

Fig. 164 On the driver door pillar: Tire inflation pressure label.

The correct tire pressure for the tires fitted at the factory can be found on a label on the B-pillar of the driver door [fig. 164](#). The factory-installed tires can be winter, summer or all-season tires.

An incorrect tire pressure can cause increased tire wear, negatively affect driving behavior and damage tires. Compliance with the correct tire pressure is very important, particularly when driving at high speeds.

The specified tire pressure is given for a cold tire. For warm tires, the pressure is higher.

Never reduce the pressure of a warm tire in order to reach the specified value. This will cause the actual pressure when the tire is cold to be too low.

⚠ WARNING

A tire pressure that is too low can result in a sudden loss of air, separation of the tire tread or bursting of the tire while driving. An incorrect tire pressure shortens the service life of the tire and negatively affects driving behavior.

An incorrect tire pressure can cause accidents and fatal injuries.

- Check the tire pressures regularly, at least once a month and also before driving long distances.
- Always adjust the tire pressure according to your load.
- Never reduce the tire pressure when tires are warm.

⚠ WARNING

Excessive speeds and vehicle overloading can cause overheating, sudden tire damage (including tire blow-outs) and separation of the tread.

This can cause accidents and fatal injuries.

- Never exceed the maximum load for the tires fitted ⇒ [Tire labeling and tire classifications](#).
- Never exceed the maximum permitted speed for the tires fitted ⇒ [Tire labeling and tire classifications](#).

ⓘ NOTICE

Careless handling of the tire pressure gage may damage the valve.

- When positioning the tire pressure gauge, make sure it is not tilted at the valve stem.

Tire pressure that is too low increases energy consumption.

Tire inflation pressure for cold tires

Power and battery capacity of the high-voltage battery	Size designation	Tire pressure		
		psi	kPA	bar
	235/55 R19 105T XL	42	290	2.9

Power and battery capacity of the high-voltage battery	Size designation	Tire pressure		
		psi	kPA	bar
150 kW, 58 (62) kWh 150 kW, 77 (82) kWh	235/50 R20 104T XL	42	290	2.9
150 kW, 77 (82) kWh	255/50 R19 107T XL	42	290	2.9
	255/45 R20 105T XL	42	290	2.9
220 kW, 77 (82) kWh	235/55 R19 105T XL	44	300	3.0
	255/50 R19 107T XL	44	300	3.0
	235/50 R20 104T XL	44	300	3.0
	255/45 R20 105T XL	44	300	3.0

Details of the correct tire pressure are located on the tire pressure label on the driver's door pillar. If the details on the tire pressure label differ from the details in the Manual, the details on the tire pressure label apply.

⁴⁾ Observe the information provided on the tire inflation pressure label on the driver door pillar.

Monitoring the tightening torque

The correct wheel bolts must always be used for each vehicle model, and these bolts must always be tightened to the correct torque. The wheel bolt tightening torque must be checked regularly with a functional torque wrench. In addition, the tightening torque must be checked immediately after each wheel change with a functional torque wrench. If the wheel bolts are not tightened enough to meet the specification, the wheel bolts and rims could come loose while driving. Exceeding the tightening specification could damage the wheel bolts and threads.

Wheel bolts that are corroded and difficult to turn must be replaced and the threads in the wheel hub must be cleaned before checking the tightening torque. Never grease or oil the wheel bolts and the threads in the wheel hub.

Wheel bolt tightening specification

The tightening torque of the wheel bolts is specified in the chapter on replacing wheels → page , *Changing a wheel*.

WARNING

If the wheel bolts are not tightened enough to meet the specification, the wheel bolts and consequently the wheel could come loose while driving. Exceeding the tightening specification could damage the wheel bolts and threads.

Wheel bolts that are tightened incorrectly or missing could cause you to lose control of the vehicle and lead to serious accidents and fatal injuries.

- Always tighten the wheel bolts to the correct tightening torque. If you do not have a torque wrench, tighten the wheel bolts with the lug wrench and then have the tightening torque checked as soon as possible by an authorized Volkswagen dealer or authorized Volkswagen Service Facility. Volkswagen recommends contacting an authorized Volkswagen dealer or authorized Volkswagen Service Facility.
- Never drive with missing or loose wheel bolts.
- Always use wheel bolts that are correct for the rim and the vehicle model.
- Never grease or oil the wheel bolts and the threads in the wheel hub. Even when tightened to the specification, the wheel bolts could become loose while driving.
- Ensure the wheel bolts and threads in the wheel hubs are clean, easy to move and free of oil and grease.
- Never loosen the bolts on rims with a bolted rim ring.

Replacing tires

Replacing wheels with the same tire and rim size on all wheels

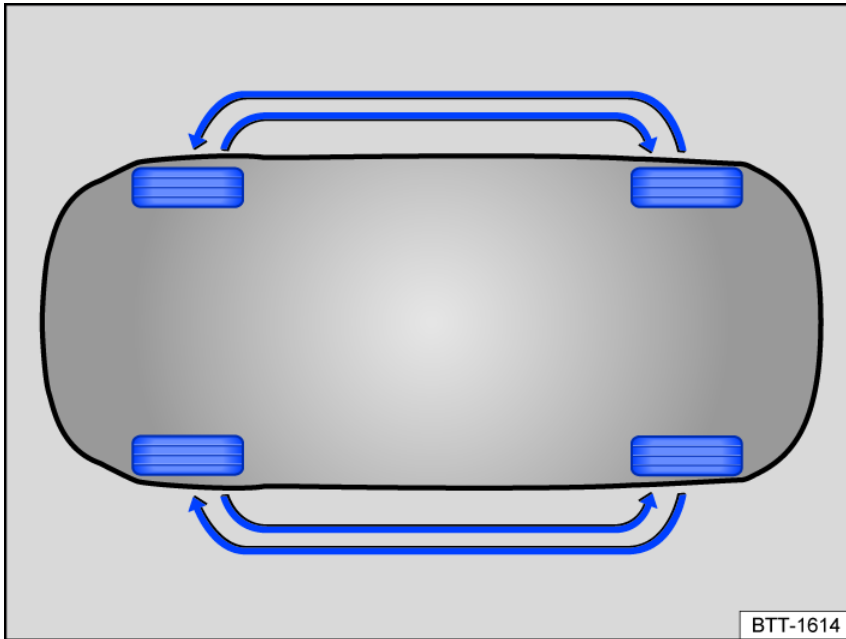

Fig. 165 General example: Diagram for replacing the wheels with the same tire and rim size on all wheels.

If all wheels have the same tire and rim size, we recommend replacing the tires regularly according to the diagram to ensure that the tires wear evenly [fig. 165. 1](#) will allow the tires to have approximately the same length of service life.

Volkswagen recommends having the wheel replacement carried out by an authorized Volkswagen dealer or authorized Volkswagen Service Facility. Volkswagen recommends contacting an authorized Volkswagen dealer or authorized Volkswagen Service Facility.

Different tire and rim sizes on front and rear axle

Your vehicle may be equipped with wheels that differ in tire and rim size on each axle. The different wheels must not be interchanged between the front and rear axles, as this may also invalidate the vehicle's operating license.

The tire size (rolling circumference) and tread pattern on the front and rear axles may differ.

Monitoring the tread depth

Tread depth

Most driving situations require a tire tread that is as deep as possible. All tires, or at least tires on the same axle, must have an even tread depth ⇒ ⚠. This applies in particular to wet or wintry road conditions.

In most countries, the legal minimum tread depth is 1.6 mm (1/16 of an inch). This is measured in the tread grooves next to the wear indicators. Observe any legal regulations specific to the country where you are driving.

Note the legal requirements in the applicable country for minimum tread depths on winter and all-season tires.

Tire wear

Tire wear depends on various factors:

- Driving style.
- Wheel balancing.
- Running gear alignment.

An imbalance can occur while driving, which can be noticed by uneven steering. Tire imbalances also affect tire wear. In these situations, have the wheels balanced again.

Incorrect wheel alignment impairs driving safety and increases tire wear. If there is a high degree of tire wear, have the wheel alignment checked by an authorized Volkswagen dealer or authorized Volkswagen Service Facility. Volkswagen recommends contacting an authorized Volkswagen dealer or authorized Volkswagen Service Facility.

Tire Wear when Driving with a Sporty Driving Style

Driving quickly around curves, rapid acceleration, and heavy braking increase tire wear.

If you drive with a sporty driving style, check the tread depth every 5000 to 10,000 km (approx. 3107 to 6214 miles).

Tread wear indicator in tires



Fig. 166 Tire tread: tread wear indicator.

The tread wear indicator is 1.6 mm (1/16 in) above the base of the tread [fig. 166](#). Markings on the sides of the tire indicate the location of the tread wear indicator [fig. 166](#).

The tread wear indicator indicates if a tire is worn out. At the latest, the tire must be replaced if the tread depth is worn down to the tread wear indicator.

When you check the tread depth, you must check the wear indicators of all tread grooves

⚠ WARNING

Worn tires are a safety risk and make it difficult to control the vehicle well. They increase the braking distance and the risk of skidding.

Worn tires have significantly less grip. Particularly on wet roads, the vehicle is more likely to “hydroplane”.

Worn tires could cause loss of vehicle control, serious accidents and death.

- Replace tires with new tires when the tires are worn down to the tread wear indicator.

Wheels and tires in snow and ice

Winter tires

Summer tires offer very little holding force on icy or snowy roads. Winter or all-season tires improve vehicle handling and braking performance in winter road conditions. Volkswagen recommends using winter tires on the vehicle at temperatures below +7 °C (+45 °F) or in winter road conditions. This also applies to vehicles with all-wheel drive (4MOTION).

The effectiveness of winter or all-season tires is greatly reduced when the tire tread is worn down to a depth of 3/16 in (4 mm).

The following applies when using winter tires:

- Follow all applicable laws in the country of operation.
- Use winter tires on all four wheels at the same time.
- Only use in winter road conditions.
- Only use the tire sizes permitted for the vehicle.
- Only use winter tires that have the same belt construction, size, and tread pattern. Exception ⇒ [Handling tires](#).
- Follow the speed restriction based on the speed rating.

Speed restriction

Winter tires have a speed restriction based on their speed rating ⇒ [Tire labeling and tire classifications](#).

A speed warning can be set in the Vehicle settings menu in the Infotainment System under the Tires menu.

On V winter tires, the speed restriction and required tire pressure depend on the engine. Always ask an authorized Volkswagen dealer or authorized Volkswagen Service Facility about the permitted speed and required tire pressure. Volkswagen recommends contacting an authorized Volkswagen dealer or authorized Volkswagen Service Facility.

⚠ WARNING

In winter road conditions, do not let the improved driving characteristics of winter tires tempt you to take safety risks, as otherwise you may lose control of the vehicle, resulting in serious injuries.

- Adapt your speed and driving style to the visibility, weather, road and traffic conditions.

 When temperatures are above +7 °C (+45 °F), summer tires provide better vehicle handling. There is less road noise, the tires wear more slowly, and economy is better.

 For vehicles with a Tire Pressure Monitoring System, the system must be recalibrated after changing to winter tires ⇒ [How the Tire Pressure Monitoring System Works](#).

 The speed limit and tire load of winter tires may differ from those of summer tires.

 You can contact an authorized Volkswagen dealer or authorized Volkswagen Service Facility for permitted winter tire sizes. Volkswagen recommends contacting an authorized Volkswagen dealer or authorized Volkswagen Service Facility.

Snow chains

Note the legal requirements and the permitted maximum speed when driving with snow chains.

Snow chains improve driving and braking handling when on roads covered with ice or snow.

Snow chains may only be mounted on the rear wheels and only on the following tire/rim combinations:

Battery capacity for high-voltage battery	Tire size	Rim
52 (55) kWh, 58 (62) kWh	235/55 R19	8 J x 19 ET45
77 (82) kWh	255/50 R19	8 J x 19 ET45

If possible, use fine-mesh snow chains that include a chain lock no larger than 12 mm (approx. 15/32 in).

Volkswagen recommends contacting an authorized Volkswagen dealer or authorized Volkswagen Service Facility for more information about wheel, tire, and snow chain sizes. Volkswagen recommends contacting an authorized Volkswagen dealer or authorized Volkswagen Service Facility.

Snow chains may only be used on tire/rim combinations that are approved for snow chain operation.

If using snow chains, remove the wheel covers and rim accent rings before mounting the snow chains. However, the wheel bolts must be covered with caps for safety reasons. Caps can be obtained from an authorized Volkswagen dealer or authorized Volkswagen Service Facility. Volkswagen recommends contacting an authorized Volkswagen dealer or authorized Volkswagen Service Facility.

Using snow chains on the compact spare tire or collapsible spare tire

Using snow chains on the compact spare tire or collapsible spare tire is not permitted for technical reasons.

1. If a rear tire is flat, mount the compact spare wheel or collapsible spare wheel on the front axle.
2. Replace the damaged rear wheel with the removed front wheel. Pay attention to the running direction when doing this.

The vehicle may be equipped with wheels that differ in tire and rim size on each axle. The different wheels must not be interchanged between the front and rear axles, as this may also invalidate the vehicle's operating license. In this case, snow chains must not be used with a compact spare wheel or collapsible spare wheel on the vehicle.

Volkswagen recommends attaching the snow chains before mounting the wheel.

WARNING

Using unsuitable snow chains or installing snow chains incorrectly can cause serious accidents and death.

- Always use the correct snow chains.
- Only use snow chains on the tire/rim combinations approved by Volkswagen.
- Follow the installation instructions provided by the snow chain manufacturer.
- Never drive faster than intended according to the specifications of the snow chain manufacturer or permitted by law when snow chains are mounted.

NOTICE

If snow chains are used on routes that are not snowy, they will impair the driving characteristics, damage the tires, and be quickly destroyed.

- Remove snow chains when driving on roads without snow.

NOTICE

Snow chains that come into contact with the rim directly can scratch or damage the rim.

- To prevent damage, use snow chains with integrated rim protection.

 On vehicles with a Tire Pressure Monitoring System, the system must be reprogrammed after snow chains are mounted ⇒ [How the Tire Pressure Monitoring](#)

Troubleshooting

Damage to tires and rims can often occur where it is not visible ⇒ .

If you suspect that a wheel is damaged, slow down and stop as soon as traffic allows and it is safe to do so.

Vehicle pulls to one side or unusual vibrations

The vehicle pulls to the left or right when driving, or there are unusual vibrations. This could indicate tire damage or too low a tire inflation pressure.

 Check the tires!

Slow down immediately and stop the vehicle as soon as the traffic situation allows and it is safe to do so.

1. Check the tires and rims for damage.
2. Do not continue driving if there is tire damage.
3. Replace the damaged wheel ⇒  [Introduction](#). If necessary, contact an authorized Volkswagen dealer or authorized Volkswagen Service Facility for assistance.

Or: seal the damaged tire using the tire mobility set and inflate it with air ⇒  [Introduction](#).

4. If no exterior damage is visible, drive slowly and carefully to the nearest authorized Volkswagen dealer or authorized Volkswagen Service Facility to have the vehicle checked. Volkswagen recommends contacting an authorized Volkswagen dealer or authorized Volkswagen Service Facility.

Foreign object stuck in the tire

A foreign object is stuck in the tire or between the tread segments.

On vehicles with run-flat tires (AirStop® tires): leave the object in the tire and contact an authorized Volkswagen dealer or authorized Volkswagen Service Facility. Volkswagen recommends contacting an authorized Volkswagen dealer or authorized Volkswagen Service Facility. Sealant that has been applied to the inside of the tire running surface will surround the object and seal the tire temporarily.

1. If an object has punctured through to the inside of a tire, leave the object in place. Objects stuck between the tire tread segments can be removed.
2. Replace the damaged wheel ⇒  [Introduction](#). If necessary, contact an authorized Volkswagen dealer or authorized Volkswagen Service Facility for assistance.

Or: seal the damaged tire using the tire mobility set and inflate it with air ⇒  [Introduction](#).

3. Check and adjust the tire pressure.
4. Contact an authorized Volkswagen dealer or authorized Volkswagen Service Facility. Volkswagen recommends contacting an authorized Volkswagen dealer or authorized Volkswagen Service Facility.

Tires lose traction

The vehicle loses traction when driving along curved stretches, and swerves. The braking distance is longer and the anti-slip regulation (ASR) and the anti-lock brake system (ABS) take control earlier.

The tire may be too worn down to guarantee sufficient traction ⇒ [Monitoring the tread depth](#).

1. Go slowly and carefully to the nearest suitably qualified professional to have the vehicle checked. Volkswagen recommends contacting an authorized Volkswagen dealer or authorized Volkswagen Service Facility.

Wheel bolts can only be undone with difficulty

Wheel bolts can corrode over time. This means that the wheel bolts can only be undone with difficulty.

1. Contact professional assistance, or drive slowly and carefully to the nearest qualified professional to have the vehicle checked. Volkswagen recommends contacting an authorized Volkswagen dealer or authorized Volkswagen Service Facility.

WARNING

Unusual vibrations or the vehicle pulling to one side while driving may indicate tire damage.

Tire damage could cause loss of vehicle control, accidents and serious or fatal injuries.

- Slow down immediately and stop the vehicle as soon as the traffic situation allows and it is safe to do so.
- Check the tires and rims for damage.
- Never continue driving with damaged tires or rims. Instead, seek professional assistance.
- If no exterior damage is visible, drive slowly and carefully to the nearest authorized Volkswagen dealer or authorized Volkswagen Service Facility to have the vehicle checked. Volkswagen recommends contacting an authorized Volkswagen dealer or authorized Volkswagen Service Facility.

Tire Pressure Monitoring System

How the Tire Pressure Monitoring System Works

The Tire Pressure Monitoring System warns the driver if tire pressures are too low.

The Tire Pressure Monitoring System uses the ABS sensors to monitor the RPM and therefore the rolling circumference of the individual wheels during travel.

If a tire loses air or the tire pressure is too low, the rolling circumference is reduced and the RPM increases.

The Tire Pressure Monitoring System shows a change in the rolling circumference of the tires via the  indicator light in the instrument cluster.

However, the following situations can also cause changes in the RPM

- The tire pressure has changed
- The tire has structural damage
- One side of the vehicle has a heavier load than the other
- Snow chains are installed on the tires
- A compact spare wheel has been installed
- Only one wheel was replaced on each axle

 **The Tire Pressure Monitoring System will not work if the ESC or ABS is malfunctioning** ⇒ [Troubleshooting](#).

Reference Pressure

The reference pressure for the Tire Pressure Monitoring System is the recommended tire pressure for the tires installed at the factory when the tires are cold at maximum load. The reference pressure corresponds to the details on the tire pressure label ⇒ [Checking the tire pressure](#).

If the tire pressure has been correctly adjusted on all four tires, the Tire Pressure Monitoring System must be re-calibrated ⇒ [Calibrating the Tire Pressure Monitoring System](#). This adapts the reference pressure to the current tire pressure.

The Tire Pressure Monitoring System  may not react at first or may not react at all when you are driving in a sporty manner, or on snow-covered or unpaved roads, when you are driving with snow chains, or in certain other situations. A change in the tread circumference of a tire is signaled by the Tire Pressure Monitoring System indicator in the instrument cluster (telltale).

The tire pressure recommended for the tires originally installed on the vehicle is on a sticker on the driver door jamb.

Each tire, including the spare (if provided), should be checked monthly when cold and inflated to the inflation pressure recommended by the vehicle manufacturer on the vehicle placard or tire inflation pressure label. (If your vehicle has tires of a different size than the size indicated on the vehicle placard or tire inflation pressure label, you should determine the proper tire inflation pressure for those tires).

As an added safety feature, your vehicle has been equipped with a tire pressure monitoring system (TPMS) that illuminates a low tire pressure telltale when one or more of your tires is significantly under-inflated. Accordingly, when the low tire pressure telltale illuminates, you should stop and check your tires as soon as possible, and inflate them to the proper pressure. Driving on a significantly under-inflated tire causes the tire to overheat and can lead to tire failure. Under-inflation also reduces fuel efficiency and tire tread life, and may affect the vehicle's handling and stopping ability.

Please note that the TPMS is not a substitute for proper tire maintenance, and it is the driver's responsibility to maintain correct tire pressure, even if under-inflation has not reached the level to trigger illumination of the TPMS low tire pressure telltale.

Your vehicle has also been equipped with a TPMS malfunction indicator to indicate when the system is not operating properly. The TPMS malfunction indicator is combined with the low tire pressure telltale. When the system detects a malfunction, the telltale will flash for approximately one minute and then remain continuously illuminated. This sequence will continue upon subsequent vehicle start-ups as long as the malfunction exists.

When the malfunction indicator is illuminated, the system may not be able to detect or signal low tire pressure as intended. TPMS malfunctions may occur for a variety of reasons, including the installation of replacement or alternate tires or wheels on the vehicle that prevent the TPMS from functioning properly. Always check the TPMS malfunction telltale after replacing one or more tires or wheels on your vehicle to ensure that the replacement or alternate tires and wheels allow the TPMS to continue to function properly.

WARNING

The Tire Pressure Monitoring System is not a replacement for the driver's attention and works only within the system limitations. The Tire Pressure Monitoring System cannot detect all driving situations and may not react, or may react with a delay, or may react in a way that is not desired. If you are careless, there is a risk of accidents, serious injuries and death.

- Always stay attentive and do not rely solely on the Tire Pressure Monitoring System. The driver is always responsible for adhering to the correct tire inflation pressure.
- Observe the system limitations ⇒ [Limitations of the Tire Pressure Monitoring System](#).
- Regularly check the tire pressure when the tires are cold and always maintain the specified pressures as stated on the tire inflation pressure label for the tires fitted on the vehicle ⇒ [Checking the tire pressure](#).
- Check the tires regularly for signs of wear or damage and replace worn or damaged tires immediately.
- Never exceed the maximum permissible speed and tire load specified for the tires fitted to your vehicle.

⚠ WARNING

Driving with too low a tire inflation pressure could cause the tire to become so hot that the tread could separate, the tire could rupture, and you could lose control of the vehicle.

Tire pressure that is too high or too low shortens the service life of the tire and affects driving behavior.

Different tire pressures or low tire pressures can increase tire wear, decrease vehicle stability, increase braking distance, and result in tire damage, tire failure and loss of vehicle control.

This can cause serious accidents and fatal injuries.

- Always pay attention to the warnings given by the Tire Pressure Monitoring System. If the  indicator light turns on, stop the vehicle immediately where it is safe to do so and check all tires ⇒ [Checking the tire pressure](#).
- The driver is responsible for maintaining the correct tire pressure. Regularly check the tire pressure when the tires are cold and always maintain the specified pressures as stated on the tire inflation pressure label for the tires fitted on the vehicle ⇒ [Checking the tire pressure](#). The Tire Pressure Monitoring System (TPMS) can only function correctly when all tires are inflated to the correct pressure when they are cold.
- If the tire is not “flat” and the tire does not need to be replaced immediately, drive slowly to the nearest authorized Volkswagen dealer or authorized Volkswagen Service Facility to have the tire pressure checked and corrected ⇒ [Checking the tire pressure](#). Volkswagen recommends contacting an authorized Volkswagen dealer or authorized Volkswagen Service Facility.
- Always set up the Tire Pressure Monitoring System correctly .

⚠ WARNING

Excessive speeds and vehicle overloading can cause overheating, sudden tire damage (including tire blow-outs) and separation of the tread.

This can cause accidents and fatal injuries.

- Never exceed the maximum load for the tires fitted ⇒ [Tire labeling and tire classifications](#).
- Never exceed the maximum permitted speed for the tires fitted ⇒ [Tire labeling and tire classifications](#).

 Low tire pressures increases energy use and tire wear.

 **New tires may expand slightly the first time they are driven at high speeds, which can trigger a tire pressure warning.**

 **Only replace old tires with tires that have been approved by Volkswagen for the vehicle model.**

 **Do not rely on the Tire Pressure Monitoring System alone. Inspect the tires regularly to make sure the tire pressure is correct and check the tires for any signs of damage, such as punctures. Remove any objects stuck in the tire tread as long as they have not punctured the inside of the tire.**

Limitations of the Tire Pressure Monitoring System

Regular Maintenance

The Tire Pressure Monitoring System is not intended to replace regular inspection and maintenance of the tires. The driver is responsible for ensuring that the correct tire pressure is used at all times, even if the Tire Pressure Monitoring System is not showing a warning that the tire pressure is too low.

The tire pressure of all tires must be checked once a month when the tires are cold and must correspond to the vehicle manufacturer's specifications on the tire inflation pressure label.

This also applies to the tire pressure of the spare wheel or compact spare wheel.

The recommended tire pressure for the tires installed at the factory is specified on the tire inflation pressure label ⇒ [Checking the tire pressure](#).

Unresolved Malfunctions

If the Tire Pressure Monitoring System displays a malfunction, the tire pressure cannot be monitored correctly. A malfunction in the Tire Pressure Monitoring System can have a number of causes, e.g. a wheel or a tire being replaced. After replacing a wheel or tire, you must check whether the  indicator light displays a system malfunction to make sure that the Tire Pressure Monitoring System is working properly ⇒ [Troubleshooting the Tire Pressure Monitoring System](#).

Sporty driving

The Tire Pressure Monitoring System may be delayed or not be displayed at all when driving with a sporty style, on winter or unpaved roads, or when driving with snow chains.

Calibrating the Tire Pressure Monitoring System

The Tire Pressure Monitoring System must be recalibrated under the following conditions:

- If the tire pressures were adjusted.
- If one or more wheels were changed.

- If one or more wheels were repaired.
- If the wheels were rotated, for example from front to rear.

The Tire Pressure Monitoring System must only be recalibrated if all tires are inflated to the correct pressure when they are cold. In order to measure the tire pressure on cold tires, the vehicle must be left to stand for 3 hours or only be driven slowly over short distances during this time.

 **After being warned about a low tire pressure, switch the ignition off and back on. The Tire Pressure Monitoring System can only be recalibrated after this is done.**

1. Switch the ignition on.
2. Switch the Infotainment system on.
3. Tap **Vehicle** in the Infotainment system.
4. Tap **Vehicle** (left-hand side).
5. Tap **Tires**.
6. Tap **SET**.
7. If all four tires meet the required tire pressure values, tap **OK**.

After travel times of at least 20 minutes and at different vehicle speeds, the system adapts to the new values and monitors them.

WARNING

If the Tire Pressure Monitoring System has been calibrated with a tire pressure that is too high or low, the Tire Pressure Monitoring System may give false warnings or fail to give a warning when the tire pressure is dangerously low.

- Ensure that the tire pressure is correct on all wheels before calibrating the Tire Pressure Monitoring System.

Troubleshooting the Tire Pressure Monitoring System

Tire pressure low

The yellow indicator light turns on.

The tire pressure of one or more tires has decreased or the tire is structurally damaged.

1.  Stop the vehicle immediately where it is safe to do so.
2. Check the tires for visible damage.
3. If there is no visible damage on the tires, drive at reduced speed to the nearest gas station and check the tire pressure. Adjust it if necessary.
4. If one of the tires is damaged, change the damaged wheel → *Wheel change*. If necessary, contact an authorized Volkswagen dealer or authorized Volkswagen Service Facility for assistance.
Or: seal the damaged tire using the tire mobility set and inflate it with air → *Tire mobility set*.
5. Recalibrate the Tire Pressure Monitoring System → *How the Tire Pressure Monitoring System Works*.
6. If the malfunction persists, contact a suitably qualified professional. Volkswagen recommends contacting an authorized Volkswagen dealer or authorized Volkswagen Service Facility.

Tire Pressure Monitoring System malfunction

The yellow indicator light flashes for approximately one minute and then stays on.

There is a system malfunction.

1.  **Do not continue driving!**
2. Switch the ignition off and back on again.
3. Recalibrate the Tire Pressure Monitoring System → *How the Tire Pressure Monitoring System Works*.
4. If the malfunction persists, contact a suitably qualified professional. Volkswagen recommends contacting an authorized Volkswagen dealer or authorized Volkswagen Service Facility.

 **Driving on unpaved roads for a long period of time or sporty driving can deactivate the Tire Pressure Monitoring System temporarily. If there is a malfunction, the indicator light flashes for approximately one minute and then stays on. However, the indicator light will turn off if the road conditions or driving style changes.**

Wheel change

Introduction

Only change the wheel yourself if the vehicle is parked securely, you are familiar with the safety precautions and the necessary procedures and you have the necessary tools. Some vehicles are delivered from the factory without a vehicle jack and lug wrench. In such cases, have the wheel changed by an authorized

Volkswagen dealer or authorized Volkswagen Service Facility. Volkswagen recommends contacting an authorized Volkswagen dealer or authorized Volkswagen Service Facility.

The vehicle jack supplied by the factory is only designed for changing one wheel that has a damaged tire and must be replaced. If both tires on one side of the vehicle, both tires on one axle, or all tires are damaged, contact an authorized Volkswagen dealer or authorized Volkswagen Service Facility for assistance. Volkswagen recommends contacting an authorized Volkswagen dealer or authorized Volkswagen Service Facility.

You must carry out the following steps to change a wheel.

1. Prepare the vehicle for the wheel change ⇒ [Preparing Your Vehicle](#).
2. Remove the wheel hub cover or wheel bolt caps ⇒ [Removing and Fitting Wheel Hub Covers](#), ⇒ [Removing and Fitting Hubcaps](#), ⇒ [Removing and Fitting the Wheel Bolt Caps](#).
3. Loosen the wheel bolts ⇒ [Loosening wheel bolts](#).
4. Jack up the car ⇒ [Raising the vehicle with the vehicle jack](#).
5. Remove the damaged wheel and fit the spare wheel, collapsible spare wheel or compact spare wheel ⇒ [Changing a wheel](#).

WARNING

It can be dangerous to change a wheel at the roadside.

If the vehicle and work area are not secured properly, serious accidents and fatal injuries may occur.

- Only carry out the wheel change yourself if you are familiar with the necessary steps. Instead, seek assistance from an authorized Volkswagen dealer or authorized Volkswagen Service Facility. Volkswagen recommends contacting an authorized Volkswagen dealer or authorized Volkswagen Service Facility.
- Stop the vehicle as soon as it is safe to do so.
- Park the vehicle a safe distance from moving traffic.
- To reduce the risk of the vehicle moving unintentionally, always deactivate the vehicle's drive system and switch the ignition off ⇒ [Parking](#).
- Move all passengers, particularly children, to a safe distance away from the working area on the side facing away from moving traffic.
- Switch on the emergency flashers to warn other road users and set up the warning triangle.
- Only jack up the vehicle on level, firm ground. Sloped or soft ground can cause the vehicle to slip off the jack. If necessary, place a large, stable surface under the jack.
- If you are on a slippery surface such as tile, place a non-slippery object such as a rubber mat on the ground to prevent the jack from slipping.
- Only use suitable and undamaged tools for wheel changes.
- After changing a wheel, immediately check the tightening torque of the wheel bolts with an undamaged torque wrench that is functioning correctly.
- If your vehicle is equipped with a Tire Pressure Monitoring System, you must recalibrate the system immediately after a wheel is changed ⇒ [How the Tire Pressure Monitoring System Works](#).

Preparing Your Vehicle

 Please read the introductory information and heed the Warnings and Notice ⇒  [Introduction](#).

Checklist

Always perform the following steps in the specified order to prepare for a wheel change ⇒ :

1. Park the vehicle a safe distance from moving traffic. Observe all important information on parking when doing so ⇒ [Parking](#). The ground must be level and firm. Sloped or soft ground can cause the vehicle to slip off the jack. If necessary, place a large, stable surface under the vehicle jack.
2. Switch on the emergency flashers ⇒ [Center console](#).
3. Have all vehicle occupants exit the vehicle on the side facing away from traffic and move to a safe area, such as behind a guard rail. Follow the local regulation regarding wearing a reflective vest.
4. Set up the warning triangle to warn others on the road about the vehicle.
5. Adjust the steering wheel so that the wheels are not pointing straight forward.
6. Block the tire that is diagonal from the one you will be changing with a stone, chocks, or another suitable object.
7. In trailer mode: Disconnect the trailer from the towing vehicle and park it ⇒ [Trailer towing](#).
8. If the luggage compartment is full: remove the contents from the luggage compartment.
9. Remove the vehicle toolkit from the luggage compartment.

WARNING

Failing to heed this checklist that is provided for your own safety can cause accidents and serious injuries.

- Always follow the tasks in the checklist.

- Observe the general safety precautions.

Removing and Fitting Hubcaps

📖 Please read the introductory information and heed the Warnings and Notice ⇒ ⚠️ *Introduction*.

Removing Hubcaps



Fig. 167 Remove the hubcap.

The wheel center trim is for protecting the wheel bolts and must be reattached after a wheel change.

1. Take the extraction hook out of the vehicle toolkit ⇒ *Vehicle tool kit components* and insert it into a hole (alloy wheel) or hook it onto the edge (steel wheel) of the hubcap *fig. 167*.
2. Remove the trim in the direction of the arrow *fig. 167*.

Fitting Hubcaps

1. Press the hubcap centrally onto the rim and press it against the rim until it you feel it engage.

⚠️ WARNING

Unsuitable wheel covers and assembling wheel covers incorrectly can cause accidents and serious injuries.

Wheel covers that are installed incorrectly can loosen while driving and endanger other road users.

- Do not use damaged hubcaps.
- Check whether the hubcap is securely engaged all the way around.

⚠️ WARNING

Hubcaps that are installed incorrectly can cause the air supply for cooling the brakes to be interrupted or reduced. This also applies when wheel covers are retrofitted. An insufficient air supply can cause the braking distance to increase significantly.

This can cause accidents and fatal injuries.

- Check whether the hubcap is securely engaged all the way around.

Removing and Fitting Wheel Hub Covers

📖 Please read the introductory information and heed the Warnings and Notice ⇒ ⚠️ *Introduction*.

Removing wheel hub covers



Fig. 168 Remove the wheel hub cover.

The full wheel covers protect the wheel bolts and must be reattached after a wheel change.

1. Take the extraction hook out of the vehicle tool kit ⇒ *Vehicle tool kit components*.
2. Engage the extraction hook in one of the openings on the wheel hub cover.
3. Remove the wheel hub cover with extraction hook in the direction of the arrow. If necessary, use a lug wrench for removal *fig. 168*.

Installing the full wheel cover

1. Make sure the anti-theft wheel bolts are positioned correctly ⇒ *Changing a wheel*.
2. Press the full wheel cover onto the rim so that the opening for the valve aligns with the tire valve. Make sure that the entire outer edge of the cover is secured.

⚠ WARNING

Unsuitable wheel covers and assembling wheel covers incorrectly can cause accidents and serious injuries.

Wheel covers that are installed incorrectly can loosen while driving and endanger other road users.

- Do not use damaged hubcaps.
- Check whether the wheel hub cover is securely engaged all the way around.

⚠ WARNING

Hubcaps that are installed incorrectly can cause the air supply for cooling the brakes to be interrupted or reduced. This also applies when wheel covers are retrofitted. An insufficient air supply can cause the braking distance to increase significantly.

This can cause accidents and fatal injuries.

- Check whether the cut-out for the tire valve in the wheel hub cover is in the right position.
- Check whether the wheel hub cover is securely engaged all the way around.

ⓘ NOTICE

The wheel hub cover might be screwed on tightly and may be damaged if it is pulled off.

- Do not use force to remove tightly screwed wheel hub covers.

Removing and Fitting the Wheel Bolt Caps

📖 Please read the introductory information and heed the Warnings and Notice ⇒ ⚠ *Introduction*.

Removing the Caps



Fig. 169 Remove the caps from the wheel bolts.

The caps are for protecting the wheel bolts and must be completely reattached after a wheel change.

1. Take the extraction hook out of the vehicle tool kit ⇒ *Vehicle tool kit components*.
2. Insert the extraction hook into the opening in the cap.
3. Remove the cap with extraction hook in the direction of the arrow *fig. 169*.

Putting on Caps

1. Push the cap all the way onto the wheel bolts.

The anti-theft wheel bolt has a separate cap. This cap only fits on the anti-theft wheel bolt and not on conventional wheel bolts.

Loosening wheel bolts

📖 Please read the introductory information and heed the Warnings and Notice ⇒ ⚠️ *Introduction*.



Fig. 170 Changing a tire: loosening the wheel bolts.

Use a suitable lug wrench to loosen the wheel bolts.

Only loosen the wheel bolts a few turns while the vehicle is not raised with the vehicle jack.

1. Slide the lug wrench all the way onto the wheel bolt.
2. Hold the end of the lug wrench and turn the wheel bolt about one turn counterclockwise ⇒ ⚠️.

👉 If a wheel bolt cannot be loosened, carefully press on the end of the lug wrench using your foot. Hold onto the vehicle firmly while doing this and make sure you have secure footing.

Loosening anti-theft wheel bolts

1. Remove the adapter for anti-theft wheel bolts from the vehicle tool kit.
2. Slide the adapter all the way onto the anti-theft wheel bolt.
3. Slide the lug wrench all the way onto the adapter.
4. Hold the end of the lug wrench and turn the wheel bolt about one turn counterclockwise ⇒ ⚠.

ⓘ If a wheel bolt cannot be loosened, carefully press on the end of the lug wrench using your foot. Hold onto the vehicle firmly while doing this and make sure you have secure footing.

⚠ WARNING

If the wheel bolts are removed or loosened by more than one rotation before the vehicle is jacked up, the wheel could fall off and the vehicle might tip.

This can result in serious injuries.

- Only loosen the wheel bolts about one turn while the vehicle is not lifted with the jack.
- Never place any part of your body, such as your arm, under the vehicle while you loosen the wheel bolts.

Raising the vehicle with the vehicle jack

📖 Please read the introductory information and heed the Warnings and Notice ⇒ ⚠ Introduction.

Lift points



Fig. 171 Mounting points for the vehicle jack.

The vehicle jack must only be positioned at the reinforced areas on the underbody that are located behind the markings on the vehicle body *fig. 171*. Always use the lift point that is nearest to the wheel you are changing ⇒ ⚠.

Positioning the vehicle jack

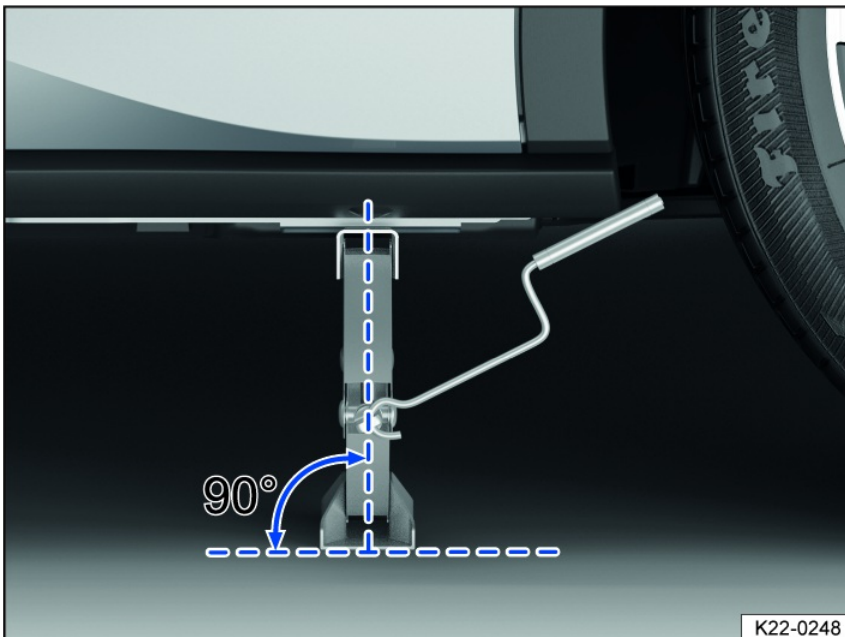

Fig. 172 Correct jack setup.

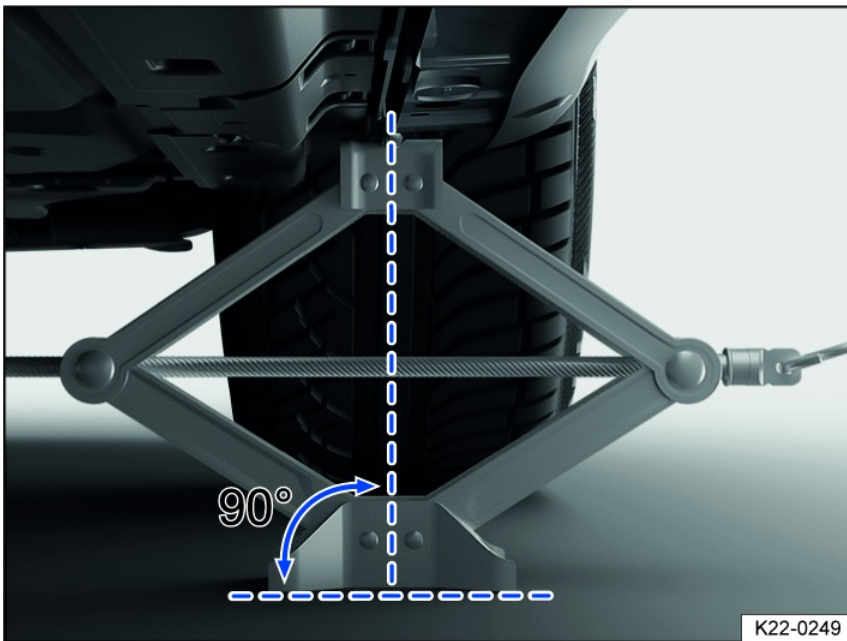

Fig. 173 Jack is positioned on the left side of the vehicle at the rear.

Checklist

For your own safety, follow the points below in the order they are given ⇒ ⚠:

1. Position the hand crank in the mount on the jack.
2. Find the vehicle lift point *fig. 171* under the vehicle that is closest to the wheel you will be changing.
3. Crank the jack upward so that it is still positioned under the vehicle lift point.
4. Make sure the entire base of the jack is seated securely on the ground and that the base of the jack is located exactly directly below the lift point *fig. 172* and *fig. 173*.
5. Straighten the jack and continue cranking the claw on the top of the jack upward until the claw is positioned on the jacking point under the vehicle *fig. 173*.
6. Continue raising the vehicle jack until the wheel is lifted off the ground.

⚠ WARNING

Failing to heed this checklist that is provided for your own safety can cause accidents and serious injuries.

- Always follow the tasks in the checklist.
- Observe the general safety precautions.

⚠ WARNING

Using the vehicle jack incorrectly can result in the vehicle slipping from the jack and cause serious or fatal injuries.

- Never raise the vehicle if more than one tire is damaged.
- Only place the vehicle jack at the lift points described. The bracket on the vehicle jack must firmly grip the sill *fig. 173*.
- Only use jacks that are approved by Volkswagen for the vehicle. Other vehicle jacks, including those approved for other Volkswagen models, could slip.
- Only jack up the vehicle on level, firm ground. Sloped or soft ground can cause the vehicle to slip off the jack. If necessary, place a large, stable surface under the jack.
- If you are on a slippery surface such as tile, place a non-slippery object such as a rubber mat on the ground to prevent the jack from slipping.
- Never place any part of your body, such as your arm, under the vehicle when it is supported only by the jack. If you must work underneath the vehicle, additionally support the vehicle securely with suitable stands.

Changing a wheel

📖 Please read the introductory information and heed the Warnings and Notice ⇒ ⚠ *Introduction*.

Removing a wheel



Fig. 174 Wheel change: removing wheel bolts with the lug wrench.

1. Follow the checklist ⇒ *Preparing Your Vehicle*.
2. Loosen the wheel bolts ⇒ *Loosening wheel bolts*.
3. Raise the vehicle ⇒ *Raising the vehicle with the vehicle jack*.
4. Remove loose wheel bolts completely using the lug wrench *fig. 174* and place the bolts on a clean surface.
5. Remove the wheel.

Two-piece wheel bolts

Two-piece wheel bolts must be used. Two-piece wheel bolts have the bolt connected loosely to the head.

Do not use single piece wheel bolts. If you are not sure which wheel bolts to use for your vehicle, consult an authorized Volkswagen dealer or authorized Volkswagen Service Facility. Volkswagen recommends contacting an authorized Volkswagen dealer or authorized Volkswagen Service Facility.

Installing a spare wheel or compact spare wheel

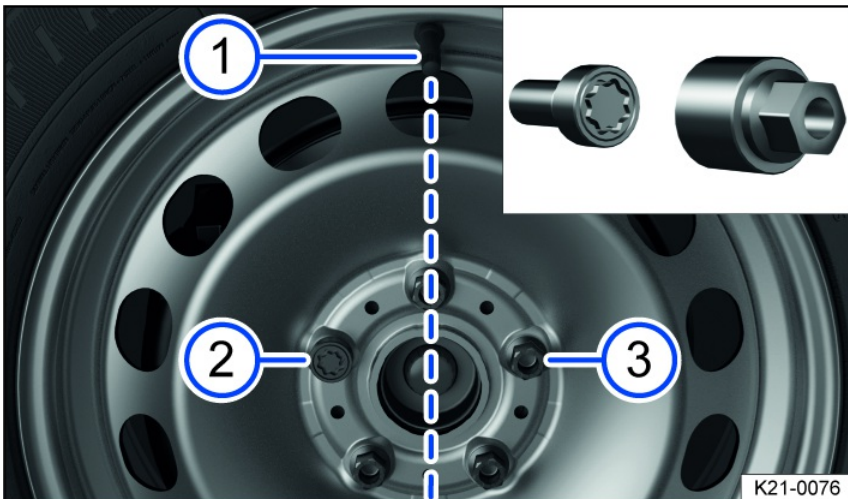

Fig. 175 Changing a tire: tire valve ① and locations of the anti-theft wheel bolt ② or ③.

1. Note the running direction of the tire ⇒ *Tire labeling and tire classifications*.
2. Position the wheel.
3. Install the anti-theft wheel bolt clockwise using the adapter in the correct position and lightly tighten.
 On wheels with full wheel covers, the anti-theft wheel bolt must be fitted in position *fig. 175* ② or ③, based on the position of the tire valve ①. Otherwise, it will not be possible to install the full wheel cover.
4. Screw in the other wheel bolts clockwise, tightening them slightly.
5. Lower the vehicle with the vehicle jack.
6. Tighten all wheel bolts securely clockwise using the lug wrench ⇒ ⚠. Do not go in order around the wheel while doing this, but rather always switch to a wheel bolt on the opposite side.

7. Fit the caps or hubcap ⇒ *Removing and Fitting Wheel Hub Covers*, ⇒ *Removing and Fitting Hubcaps*, ⇒ *Removing and Fitting the Wheel Bolt Caps*.

After a wheel change

1. Clean the vehicle tool kit and place it back in the foam piece in the luggage compartment.
2. Stow the old wheel securely in the luggage compartment.
3. Get the tightening torque of the wheel bolts checked as soon as possible at the nearest authorized Volkswagen dealer or authorized Volkswagen Service Facility. Volkswagen recommends contacting an authorized Volkswagen dealer or authorized Volkswagen Service Facility.
4. Get the damaged tires replaced as soon as possible.

Wheel bolt tightening specification

Tightening specification for wheel bolts in steel and aluminum alloy rims:

- **120 Nm (88 ft-lbs).**

Wheel bolts that are corroded and difficult to turn must be replaced and the threads in the wheel hub must be cleaned before checking the tightening torque.

Never grease or oil the wheel bolts and the threads in the wheel hub.

Check the tightening torque using a functioning torque wrench immediately after changing a wheel.

WARNING

If the wheel bolts are not tightened enough to meet the specification, the wheel bolts and the wheel could come loose while driving. Exceeding the tightening specification could damage the wheel bolts and threads.

Wheel bolts that are tightened incorrectly or missing could cause you to lose control of the vehicle and lead to serious accidents and fatal injuries.

- Always tighten the wheel bolts to the correct tightening torque. If you do not have a torque wrench, tighten the wheel bolts with the lug wrench and then have the tightening torque checked as soon as possible by suitably qualified professionals. Volkswagen recommends contacting an authorized Volkswagen dealer or authorized Volkswagen Service Facility.
- Never drive with missing or loose wheel bolts.
- Always use wheel bolts that are correct for the rim and the vehicle model.
- Never grease or oil the wheel bolts and the threads in the wheel hub. Even when tightened to the specification, they could become loose while driving.
- Ensure the wheel bolts and threads in the wheel hubs are clean, easy to move and free of oil and grease.
- Never loosen the bolts on rims with a bolted rim ring.

WARNING

Incorrect wheel bolts can loosen while driving and cause loss of vehicle control, serious accidents, and fatal injuries.

- Always use wheel bolts that are correct for the rim and the vehicle model.
- Never use different wheel bolts.
- Use only two-piece wheel bolts on vehicles with two-piece wheel bolts.

 The Tire Pressure Monitoring System (TPMS) indicator light may indicate a system malfunction after a wheel is changed ⇒ *Troubleshooting the Tire Pressure Monitoring System*.

Tire mobility set

Introduction

The tire mobility set allows you to temporarily and reliably seal tire damage caused by foreign bodies or punctures of up to around 4 mm in diameter. Do not remove the foreign body, such as a screw, from the tire!

After the sealant has filled the tire, check and adjust the tire pressure again after a drive of approximately 10 minutes.

If more than one vehicle tire is damaged, seek advice from an authorized Volkswagen dealer or authorized Volkswagen Service Facility. The tire mobility set is only designed to fill one tire.

Only use the tire mobility set when the vehicle is safely parked and you are confident of the necessary skills and safety precautions! Otherwise, contact an authorized Volkswagen dealer or authorized Volkswagen Service Facility for assistance.

Do not use the tire sealant:

- When the wheel rim is damaged.
- In outside temperatures of below -20 °C (-4 °F).
- When cuts or punctures to the tire are larger than 4 mm.

- If you have driven with a very low tire pressure or an empty tire.
- If the tire filler bottle is past its use-by date.
- If a foreign body has been removed from the tire.
- In combination with an AirStop® tire. You can tell if your vehicle is equipped with AirStop® tires by the lettering "Seal" on the outside of the tire.

WARNING

It can be dangerous to use the tire mobility set at the roadside.

If the vehicle and work area are not secured properly, serious accidents and fatal injuries may occur.

- Only use the tire mobility set yourself if you are familiar with the necessary steps. Instead, seek assistance from an authorized Volkswagen dealer or authorized Volkswagen Service Facility. Volkswagen recommends contacting an authorized Volkswagen dealer or authorized Volkswagen Service Facility.
- Stop the vehicle as soon as it is safe to do so.
- Park the vehicle a safe distance from moving traffic ⇒ *Securing yourself and the vehicle*, ⇒ *Parking*.
- Make sure the vehicle is on level and solid ground.
- All passengers, especially children, must keep a safe distance and be clear of the work area.
- Switch on the emergency flashers to warn other road users and set up the warning triangle.
- When using the tire mobility set, never raise the vehicle using a jack, even if the jack is approved for the vehicle.

WARNING

A tire filled with sealant does not have the same driving characteristics as an undamaged tire.

Over-stressing a sealed tire may result in serious accidents and fatal injuries.

- Never drive faster than 80 km/h (50 mph).
- Avoid hard acceleration, hard braking, and driving fast around curves.
- Drive at a maximum of 80 km/h (50 mph) for no more than 10 minutes and then check the tire.
- Tires sealed with the tire mobility set should be replaced immediately. The tire mobility set is only intended for emergency use in order to reach the nearest authorized Volkswagen dealer or authorized Volkswagen Service Facility. Volkswagen recommends contacting an authorized Volkswagen dealer or authorized Volkswagen Service Facility.

CAUTION

The sealing agent can be harmful if it comes into contact with your skin.

- If the sealing agent comes into contact with your skin, clean it off immediately with a cloth or other suitable item.
- Store the tire mobility set out of the reach of children.

 Dispose of used or out-of-date sealant in accordance with statutory requirements.

 **Your authorized Volkswagen dealer or authorized Volkswagen Service Facility can provide you with a new tire inflation bottle. Volkswagen recommends contacting an authorized Volkswagen dealer or authorized Volkswagen Service Facility.**

 **Read the separate operating instructions provided by the tire mobility set manufacturer.**

Preparing Your Vehicle

 Please read the introductory information and heed the Warnings and Notice ⇒  and  *Introduction*.

Checklist

Always carry out the following tasks in the specified order → .

1. Park your vehicle a safe distance from traffic and on level and firm ground. Observe all important information on parking when doing so ⇒ *Parking*.
2. Switch on the emergency flashers ⇒ *Center console*.
3. Have all vehicle occupants exit the vehicle on the side facing away from traffic and move to a safe area, such as behind a guard rail. Follow the local regulation regarding wearing a reflective vest.
4. Set up the warning triangle to warn others on the road about the vehicle.
5. Check whether a repair with the tire mobility set is possible ⇒  *Introduction*.

6. In trailer mode: Disconnect the trailer from the towing vehicle and park it ⇒ *Trailer towing*.
7. If the luggage compartment is full: remove the contents from the luggage compartment.
8. Remove the tire mobility set from the luggage compartment.
9. Do not remove the foreign body, e.g. screw, from the tire.

⚠ WARNING

Failing to heed this checklist that is provided for your own safety can cause accidents and serious injuries.

- Always follow the tasks in the checklist.
- Observe the general safety precautions.

Sealing and pumping up tires

📖 Please read the introductory information and heed the Warnings and Notice ⇒ ⚠ and ⚠ Introduction.

Sealing tires

The tire mobility set is located in the luggage compartment under the luggage compartment floor.

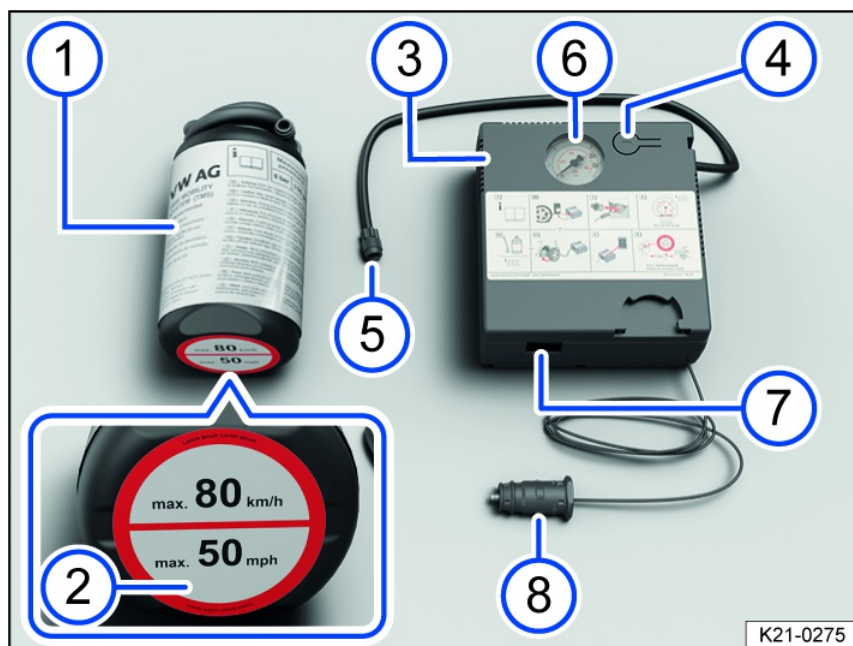

Fig. 176 Tire mobility set components (general example).

- ① Tire inflation bottle with tire filler hose and sealant.
- ② Label with the speed specification “max. 80 km/h” or “max. 50 mph”.
- ③ Compressor.
- ④ Air drain plug
- ⑤ Tire inflation hose
- ⑥ Tire pressure gauge
- ⑦ ON and OFF switch (may also be located on the side of the compressor).
- ⑧ 12 V cable connector

ⓘ The compressor from the tire mobility set may be operated at the 12 V socket, even if the power specification on the compressor label exceeds the maximum power draw of the socket.

ⓘ Instead of the air drain plug, there may also be a button on the compressor.

1. Stick the label from the tire mobility set *fig. 176* in the field of vision of the driver on the instrument panel.
2. Unscrew the valve cap from the tire valve.
3. Shake the tire inflation bottle *fig. 176* vigorously back and forth a few times.
4. Screw the compressor tire inflation hose *fig. 176* securely onto the tire inflation bottle *fig. 176* valve.
5. Screw the tire inflation hose of the tire inflation bottle *fig. 176* securely onto the tire valve.
6. Hold the bottle upside down and fit the top of the tire inflation bottle into the notch on the compressor *fig. 176*.
7. Place the compressor *fig. 176* together with the tire inflation bottle *fig. 176* on an even surface.

8. Activate the vehicle's drive system.
9. Insert the 12-volt plug into a 12-volt-socket in the vehicle ⇒ *Sockets in the vehicle*.
10. Switch the compressor on with the ON and OFF switch .
11. Leave the compressor running until 2.0 – 2.5 bar (29 – 36 psi/200 – 250 kPa) is reached. **Maximum run time: 8 minutes** ⇒ .
12. Switch off the compressor.

If a tire pressure of 2.0 – 2.5 bar (29 – 36 psi/200 – 250 kPa) cannot be reached

1. Unscrew the tire inflation hose of the tire inflation bottle from the tire valve.
2. Drive the vehicle around 10 m (approx. 33 ft) forward or backward so that the sealing agent is distributed in the tire.
3. Screw the compressor tire inflation hose directly onto the tire valve and repeat the inflation process.
4. If the required tire pressure still cannot be achieved, the tire is too badly damaged. The tire cannot be sealed with the tire mobility set. Do not continue driving . Contact an authorized Volkswagen dealer or authorized Volkswagen Service Facility for assistance.

Continuing Your Journey

1. Disconnect the compressor and unscrew the tire inflation hose from the tire valve.
2. Immediately drive at a maximum of 80 km/h (50 mph), if a tire pressure of 2.0 – 2.5 bar (29 – 36 psi/200 – 250 kPa) has been reached.
3. After driving for ten minutes, check the tire pressure.

Check after 10 minutes of driving

1. Park the vehicle on level and solid ground at the next safe opportunity, in a parking lot for example.
2. Connect the tire filler hose again and read the tire pressure off the tire pressure gauge .

1.3 bar (19 psi/130 kPa) and less:

1. **Do not continue driving!** The tire cannot be adequately sealed with the tire mobility set ⇒ . Contact an authorized Volkswagen dealer or authorized Volkswagen Service Facility for assistance.

20 psi/140 kPa (1.4 bar) and above:

1. Readjust the tire pressure to the correct value.
2. Carefully drive to the nearest authorized Volkswagen dealer or authorized Volkswagen Service Facility at a maximum of 80 km/h (50 mph). Volkswagen recommends contacting an authorized Volkswagen dealer or authorized Volkswagen Service Facility.
3. Have the damaged tire replaced at an authorized Volkswagen dealer or authorized Volkswagen Service Facility. Volkswagen recommends contacting an authorized Volkswagen dealer or authorized Volkswagen Service Facility.

WARNING

The tire inflation hose and the compressor may become hot during pumping and can cause burns if touched.

- Protect your hands and skin from hot parts.
- Do not place the hot tire inflation hose or compressor on flammable materials.
- Allow the tire inflation hose and compressor to cool before you put them away.

WARNING

If the damaged tire cannot be adequately sealed with the tire mobility set, the tire will lose air while driving.

This could cause tire failure, loss of vehicle control, accidents, and serious injuries and death.

- If the tire cannot be pumped to at least 2.0 bar (29 psi/200 kPa), the damage is too great. The sealing agent cannot seal the tire. Do not continue driving and instead seek professional assistance.
- Do not continue driving if the tire pressure is 1.3 bar (19 psi/130 kPa) or less after 10 minutes of driving. Instead, seek professional assistance.

NOTICE

The compressor can overheat and become damaged if it is used for too long.

- Switch the compressor off after it has been running for eight minutes at the most.
- Allow the compressor to cool down for several minutes before switching it on again.

Tire characteristics

Tire labeling and tire classifications

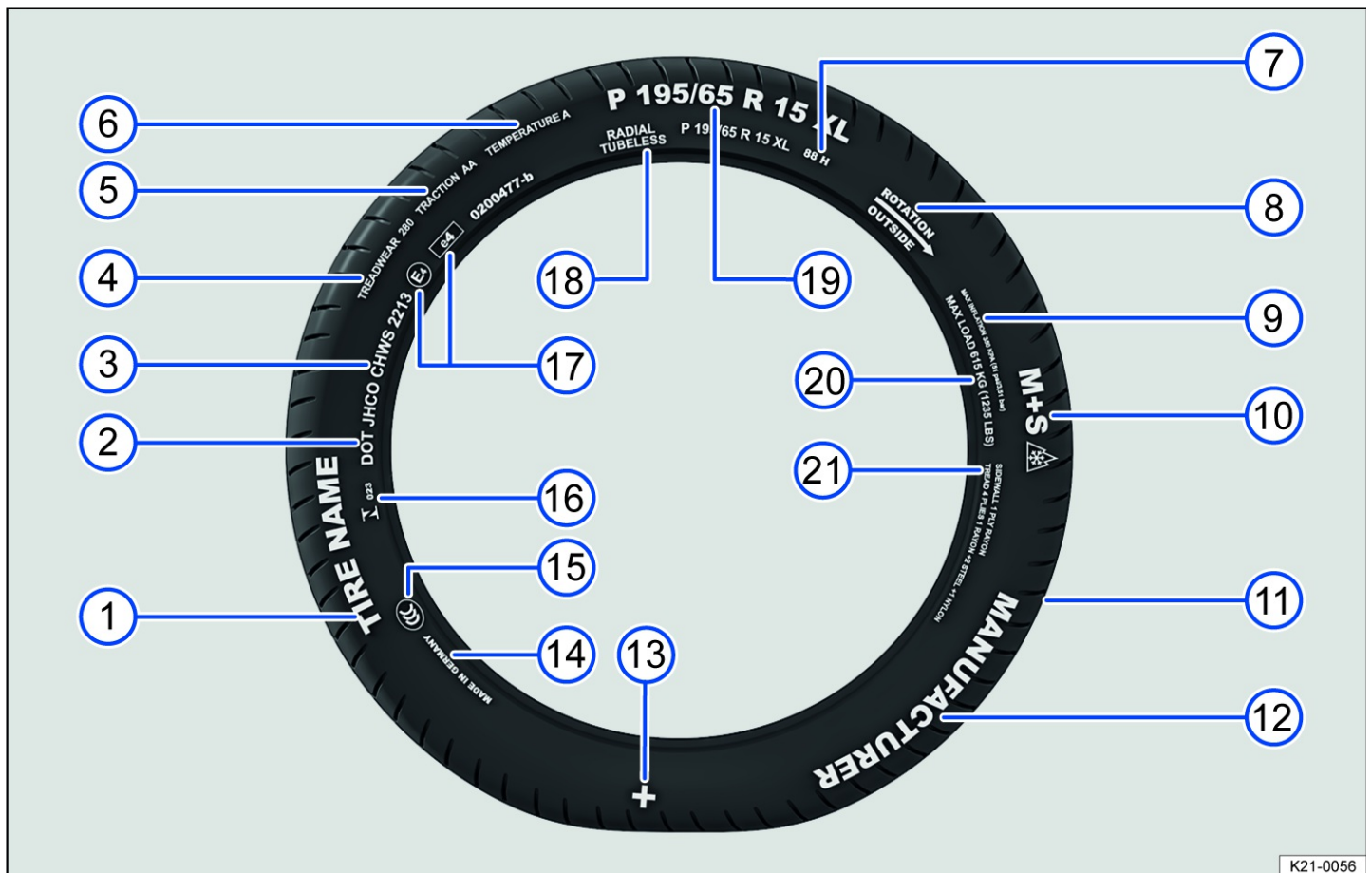





K21-0056

Fig. 177 International tire labeling.

fig. 177Tire labeling (example), meaning			
①	Product name	Individual manufacturer tire designation.	
②	DOT	The tire conforms to the legal requirements of the Department of Transportation in the USA, which is responsible for tire safety standards.	
③	JHCO CHWS 2213	Tire identification number (TIN – may only be on the inner side of the tire) and production date:	
		JHCO CHWS	Code for the factory that produced the tire and specifications from the tire manufacturer for the tire size and tire characteristics.
		2213	Production date: 22nd week in the year 2013.
Information for the end consumer about comparative values for specified base tires (standardized test procedures) ⇒ Customer information:			
④	TREADWEAR 280	Relative service life expectancy for the tire, based on a US-specific standard test. A tire with the specification 280 will wear 2.8 times more slowly than a standard tire with a tread wear value of 100. The tire performance depends on the usage conditions and may differ significantly from the standard values depending on the driving behavior, maintenance, different road conditions, and climate conditions.	
⑤	TRACTION AA	Wet braking capability of the tire (AA, A, B or C). The wet braking capability is measured under controlled conditions on certified test courses. Tires marked with C have low traction performance. The traction value assigned to tires is based on straight-line traction test and includes neither acceleration and cornering, nor hydroplaning and traction under maximum load.	
⑥	TEMPERATURE A	Temperature stability of the tire at high speeds on the test stand (A, B or C). Tires marked with A and B exceed the legal requirements. The temperature rating is based on the tires being inflated to the correct pressure and not overinflated. Excess speed, incorrect tire pressure, and overinflation either alone or in combination can cause heat to build up and cause tire damage.	

fig. 177 Tire labeling (example), meaning

7	88 H	Load index and speed rating .	
8	Rotation and arrow	Tire running direction code .	
	Or: Outside	Code on the outside of the tire .	
9	MAX INFLATION 350 KPA (51 psi/3.51 bar)	US limit for the maximum inflation pressure.	
10	M+S or M/S or 	Code for tires that can be used in the winter (mud and snow tires) ⇒ <i>Winter tires</i> . Studded tires are marked with an <i>E</i> after the <i>S</i> .	
11	TWI	Indicates the location of the tread wear indicator ⇒ <i>Monitoring the tread depth</i> .	
12	<i>Brand name, logo</i>	Manufacturer.	
13		Symbol for Volkswagen Genuine tires ⇒ <i>Handling tires</i> .	
14	Made in Germany	Country of manufacture.	
15		Country-specific code for China (China Compulsory Certification).	
16	 023	Country-specific code for Brazil.	
17	E4 e4 0200477-b	Identification according to international regulations with the number of the country that issued the approval. Approved tires in accordance with ECE regulations are marked with an <i>E</i> . Tires in accordance with EU regulations are marked with an <i>e</i> . The multi-digit approval number follows that.	
18	RADIAL TUBELESS	Tubeless radial tires.	
19	P 195 / 65 R 15 XL	Size designation:	
		P	Code for passenger vehicles.
		195	Tire width from one sidewall to the other in mm.
		65	Height and width ratio in %.
		R	Belt construction code for radial.
		15	Rim diameter in inches.
		XL	Reinforced tires ("Extra Load").
□	MAX LOAD 615 KG (1235 LBS)	US load capacity for the maximum load per tire.	
□	SIDEWALL 1 PLY RAYON	Specification for the components of the tire body. 1 layer rayon.	
	TREAD 4 PLIES 1 RAYON + 2 STEEL + 1 NYLON	Specification for the components of the running surface. In the example, there are the following 4 layers under the running surface: 1 rayon layer, 2 steel belts, and 1 nylon layer.	

The labeling is on both sides of the tire. In some cases, certain codes may only be on one side of the tire, such as the tire ID number and the production date.

Other digits that may be present are part of the internal labeling from the tire manufacturer or country-specific labeling.

Low-profile tires

Compared to other tire-rim combinations, low-profile tires offer a wider tread surface and a larger rim diameter with shorter tire sidewalls. Low-profile tires improve handling performance and precision. However, they may reduce the level of comfort when driving on roads in poor condition.

Unidirectional tires

The sidewalls on unidirectional tires are marked with arrows. The specified running direction must be followed. This ensures the optimum running characteristics.

If a tire is mounted opposite from the specified running direction, drive more carefully because the tire is not being used the way it was designed to be used. The tire must be replaced or mounted in the correct running direction as soon as possible.

Asymmetrical tires

Asymmetrical tires factor in the behavior of the inner and outer areas of the tread pattern. The sidewalls on asymmetrical tires are marked as the inner and outer

side. Maintain the correct position of the tire on the rim.

Tire load

The tire load index indicates the maximum load of an individual tires in kilograms.

Some examples:

78	425 kg (936 lbs)
81	462 kg (1018 lbs)
83	487 kg (1073 lbs)
85	515 kg (1135 lbs)
87	545 kg (1201 lbs)
88	560 kg (1234 lbs)
91	615 kg (1355 lbs)
92	630 kg (1388 lbs)
93	650 kg (1433 lbs)
95	690 kg (1521 lbs)
97	730 kg (1609 lbs)
99	775 kg (1708 lbs)
100	800 kg (1763 lbs)
101	825 kg (1818 lbs)
102	850 kg (1873 lbs)
103	875 kg (1929 lbs)
104	900 kg (1984 lbs)

Speed rating

The speed rating indicates the maximum speed that may be driven with the tire.

P	max. 150 km/h (93 mph)
Q	max. 160 km/h (99 mph)
R	max. 170 km/h (106 mph)
S	max. 180 km/h (112 mph)
T	max. 190 km/h (118 mph)
U	max. 200 km/h (125 mph)
H	max. 210 km/h (130 mph)
V	max. 240 km/h (149 mph)
W	max. 270 km/h (168 mph)
Y	max. 300 km/h (186 mph)
Z	above 240 km/h (149 mph), depending on manufacturer also ZR .

⁵⁾The TIN is the tire serial number.

UTQG tire classification

Uniform Tire Quality Grading (UTQG): Quality grades can be found where applicable on the tire sidewall between the tread shoulder and maximum section width.

Example:

- Treadwear (number)
- Traction AA, A, B or C
- Temperature A, B or C

For example: Treadwear 200, Traction AA, Temperature A.

All passenger car tires must conform to Federal Safety Requirements in addition to these grades.

Treadwear

The treadwear grade is a comparative rating based on the wear rate of the tire when tested under controlled conditions on a specified government test course.

For example, a tire graded 150 (Treadwear-value 150) would wear one-and-one-half (1 1/2) times as well on the government course as a tire graded 100.

The relative performance of tires depends upon the actual conditions of their use, however, and may depart significantly from the norm due to variations in driving habits, service practices and differences in road characteristics and climate.

Traction

The traction grades, from highest to lowest, are AA, A, B, and C. Those grades represent the tire's ability to stop on wet pavement as measured under controlled conditions on specified government test surfaces of asphalt and concrete. A tire marked C may have poor traction performance.

Temperature

The temperature grades are A (the highest), B, and C representing the tire's resistance to the generation of heat, and its ability to dissipate heat when tested under controlled conditions on a specified indoor laboratory test wheel.

Sustained high temperature can cause the material of the tire to degenerate and reduce tire life, and excessive temperature can lead to sudden tire failure.

The grade C corresponds to a level of performance which all passenger car tires must meet under the Federal Motor Vehicle Safety Standard No. 109. Grades B and A represent higher levels of performance on the laboratory test wheel than the minimum required by law.

WARNING

The traction class assigned to this tire is based on traction tests when braking straight ahead and does not take account of the properties when accelerating, driving around curves, hydroplaning or at maximum traction.

WARNING

The temperature class for this tire is based on a tire being inflated to the correct pressure and not being overinflated. Excess speeds, insufficient tire pressure, and overinflation either alone or in combination can cause heat to build up and cause potential tire failure.

Tire load and vehicle load, determining the correct load

Vehicles and tires have a limited load capacity. An overloaded vehicle is difficult to steer and brakes less effectively. Overloading your vehicle can also cause damage to the vehicle and tires, such as tire blowouts and sudden pressure losses.

To ensure your safety and the safety of your passengers, never exceed the maximum vehicle weight. This is specified as the **Gross Vehicle Weight Rating (GVWR)**.

The GVWR includes the weight of your vehicle including all additional equipment, all fluids and its maximum load. The maximum load includes the number of people that can travel in the vehicle (number of seats) with an average weight of 150 lbs (68 kg) per person, and also luggage. In trailer mode, the weight of the trailer and the trailer tongue weight rating must be included in calculations.

The **Gross Axle Weight Rating (GAWR)** is the maximum axle load per axle. The GVWR and GAWR are listed on the safety certificate on the B-pillar on the driver's side.

Your vehicle has either 4 (2 front, 2 rear), 5 (2 front, 3 rear), 6 (2 front, 2 center, 2 rear) or 7 (2 front, 3 center, 2 rear) seats, depending on the type of vehicle. Each seat has a safety belt. As there is an upper limit to the GVWR, the maximum load also has an upper limit. Traveling with a full vehicle or with passengers heavier than 150 lbs (68 kg) per person will reduce the remaining possible load.

The tire inflation pressure label for your vehicle also specifies the maximum weight.

Determining the correct tire load

Never overload tires. The following example illustrates how to determine the combined weight of all vehicle occupants and luggage or other vehicle payloads. Never overload the vehicle!

Steps for Determining Correct Load Limit:

1.	Locate the statement "The combined weight of occupants and cargo should never exceed XXX kg or XXX lbs." on your vehicle's placard.
2.	Determine the combined weight of the driver and passengers that will be riding in your vehicle.
3.	Subtract the combined weight of the driver and passengers from XXX kg or XXX lbs.
4.	The resulting figure equals the available amount of cargo and luggage load capacity. For example, if the "XXX" amount equals 1400 lbs. and there will be five 150 lb passengers in your vehicle, the amount of available cargo and luggage load capacity is 650 lbs. (1400–750 (5 × 150) = 650 lbs.)
5.	Determine the combined weight of luggage and cargo being loaded on the vehicle. That weight may not safely exceed the available cargo and luggage load capacity calculated in Step 4.

Steps for Determining Correct Load Limit:

6. If your vehicle will be towing a trailer, load from your trailer will be transferred to your vehicle. Consult this manual to determine how this reduces the available cargo and luggage load capacity of your vehicle.

Check the tire sidewall to determine the load index specified for the tire.

WARNING

Exceeding the maximum vehicle weight can cause you to lose control of the vehicle and cause accidents resulting in severe and/or fatal injuries.

- Never exceed the maximum load or the maximum vehicle weight as per the GVWR.

Glossary of tire and load terminology

Accessory weight: The combined weight (in excess of those standard items which may be replaced) of automatic transmission, electro-mechanical power steering, power brakes, power windows, power seats, radio, and heater, to the extent that these items are available as factory-installed equipment (whether installed or not).

Aspect ratio: The ratio of sidewall height to tire width, expressed as a percentage. A number of 50 (0.5:1 or 50%) means that the cross-sectional height is 50% of the tread width. A shorter sidewall can improve steering response and provide better overall handling, for example, on dry pavement.

Bead: The part of a tire made of steel wires, wrapped or reinforced by ply cords, with the shape and structure to ensure proper fit to the wheel rim.

Bead separation: A breakdown of the bond between components in the bead.

Carcass: The tire structure, except tread and sidewall rubber which, when inflated, bears the load.

Chunking: The breaking away of pieces of the tread or sidewall.

Cord: The strands of material forming the plies in the tire.

Cord separation: The parting of cords from adjacent rubber compounds.

Cracking: Any parting within the tread, sidewall, or inner liner of the tire extending to cord material.

Cold tire inflation pressure: The tire pressure recommended by the vehicle manufacturer for a tire of a specified size that has not been driven for more than a couple of miles (kilometers) at low speeds in the 3 hour period before the tire pressure is measured or adjusted.

Curb weight: The weight of a motor vehicle with standard equipment including the maximum capacity of fuel, oil, and coolant, air conditioner, and additional weight of optional equipment.

Extra load tire: A tire designed to operate at higher loads and at higher inflation pressures than the corresponding standard tire.

Gross Axle Weight Rating (GAWR): The load-carrying capacity of a single axle system, measured where the tire contacts the ground.

Gross Vehicle Weight Rating (GVWR): The maximum loaded weight of the vehicle.

Groove: The space between 2 adjacent tread ribs.

Load rating code: The maximum load that a tire is rated to carry for a given inflation pressure. You may not find this information on all tires because it is not required by law.

Maximum loaded vehicle weight: The total of:

- Curb weight.
- Accessory weight.
- Vehicle capacity weight.
- Production options weight.

Maximum (permissible) inflation pressure: The maximum cold inflation pressure to which a tire may be inflated. Also called "maximum inflation pressure."

Normal occupant weight: Means 150 lbs (68 kilograms) times the number of occupants seated in the vehicle up to the total seating capacity of your vehicle.

Occupant distribution: The placement of passengers in a vehicle.

Outer diameter: The diameter of a new, properly inflated tire.

Overall width: Total width measured at the exterior sidewalls of an inflated tire, including the additional width of labeling, decorations, or protective bands or ribs.

Passenger car tire: A tire intended for use on passenger cars, multipurpose passenger vehicles, and trucks, that have a gross vehicle weight rating (GVWR) of 10,000 pounds or less.

Ply: A layer of rubber-coated parallel cords.

Ply separation: A parting of rubber compound between adjacent plies.

Pneumatic tire: A mechanical device made of rubber, chemicals, fabric, and steel or other materials, that, when mounted on an automotive wheel, provides the traction and contains the gas or fluid that sustains the load.

Production options weight: The combined weight of installed regular production options weighing over 5 lbs (2.3 kg) more than the standard items they replace,

and not previously considered as curb weight or accessory weight. These include, for example, heavy-duty brakes, ride levelers, roof rack, heavy-duty battery, and special trim.

Radial ply tires: A pneumatic tire in which the ply cords that extend to the beads are laid at substantially 90 degrees to the centerline of the tread.

Recommended inflation pressure: The tire pressure recommended by the vehicle manufacturer for a tire of a specified size that has not been driven for more than a couple of miles (kilometers) at low speeds in the 3 hour period before the tire pressure is measured or adjusted.

Reinforced tire: A tire designed to operate at higher loads and at higher inflation pressures than the corresponding standard tire.

Rim: The outer edge of a wheel upon which the tire beads are seated.

Rim diameter: The nominal diameter of the wheel's tire bead seating surface. If you change your wheel size, to wheels of a different diameter, you will have to purchase new tires to match the new wheels.

Rim size: Designation means rim diameter and width.

Rim type designation: The industry or manufacturer's designation for a rim by style or code.

Rim width: The nominal distance between wheel rim flanges.

Section width: The linear distance between the exteriors of the sidewalls of an inflated tire, excluding elevations due to labeling decoration, or protective bands.

Sidewall: The portion of a tire between the bead and the tread.

Sidewall separation: The parting of the rubber compound from the cord material in the sidewall.

Speed rating (letter code): A standardized letter code indicating the maximum speed at which a tire is designed to be driven for extended periods of time. The ratings range from 93 mph (150 km/h) "P" to 186 mph (300 km/h) "Y". The speed rating letter code, where applicable, is molded on the tire sidewall. You may not find this information on all tires because it is not required by law.

Tire Pressure Monitoring System: A system that detects when at least one of a vehicle's tires is underinflated and illuminates a low tire-pressure warning light.

Tread: The portion of a tire that normally touches the road.

Tread rib: A tread section running circumferentially around a tire.

Tread separation: Tire failure caused by the tread pulling away from the tire carcass.

Tread wear indicators (TWI): Raised areas within the main tread grooves that show, visually, when tires are worn and near the end of their useful life.

Uniform Tire Quality Grading (UTQG): A tire information system developed by the U.S. National Highway Traffic Safety Administration (NHTSA) that is designed to help buyers compare tires. UTQG is not a safety rating, nor is it a guarantee that a tire will last for a certain number of miles or perform a certain way. It gives tire buyers more information to compare with factors such as price, brand loyalty and dealer recommendations. Under UTQG, tires are graded by the tire manufacturer in 3 areas: tread wear, traction and temperature resistance. UTQG information is molded into the tire sidewalls.

U.S. DOT Tire Identification Number (TIN): A tire's serial number. It begins with the letters "DOT" ("Department of Transportation") and indicates that the tire meets all federal standards. The next 2 numbers or letters indicate the plant where the tire was manufactured. The last 4 numbers represent the week and year of manufacture. For example, the numbers 1709 mean that the tire was produced in the 17th week of 2009. Any other numbers are marketing codes used by the tire manufacturer. This information is used to help identify affected consumers if a tire defect requires a recall.

Vehicle capacity weight: The total rated cargo, luggage and passenger load. Passenger load is 150 lbs (68 kilograms) times the vehicle's total seating capacity (as listed on the label inside the driver door).

Vehicle maximum load on the tire: The load on an individual tire that is determined by taking each axle's share of the maximum loaded vehicle weight (GAWR) and dividing by 2.

Vehicle normal load on the tire: The load on an individual tire that is determined by taking each axle's share of the curb weight, accessory weight, and normal occupant weight (distributed according to the table below) and dividing by 2.

Wheel size designation: Wheel rim diameter and width.

Occupant loading and distribution for vehicle normal load for various designated seating capacities:

Designated seating capacity, number of occupants	Vehicle normal load, number of occupants	Occupant distribution in a normally loaded vehicle
2, 3, or 4	2	2 in front
5, 6, or 7	3	2 in front, 1 in back

Maintenance

Service

Information regarding the service schedule

Information regarding maintenance of your vehicle and the type and scope of service work can be found in your service schedule. The service schedule is included with your manual Service schedule.

Vehicle care

Vehicle care information

Regular, proper care helps to maintain your vehicle.

The longer dirt remains on the surfaces of vehicle components, the more difficult it may be to clean and care for them. Long-term exposure can make it impossible for dirt to be removed.

For questions regarding care products or for vehicle components that are not listed, consult a suitably qualified professional. Volkswagen recommends contacting an authorized Volkswagen dealer or authorized Volkswagen Service Facility.

Suitably qualified professionals can provide you with suitable accessories. Volkswagen recommends the use of Genuine Volkswagen Accessories, which you can acquire from an authorized Volkswagen dealer or authorized Volkswagen Service Facility. Read and follow the usage instructions on the packaging.

WARNING

Cleaning and caring for vehicle components incorrectly can irreparably damage and impair the vehicle's safety equipment, such as the airbag modules. This may cause serious injuries in the event of an accident.

- Clean and maintain vehicle components only according to the manufacturer's instructions.
- Always use approved or recommended cleaning solution.
- Never use cleaning solutions that contain solvents.

WARNING

Cleaning the vehicle incorrectly may result in serious injuries.

- Protect your hands and arms against components with sharp edges, for example when cleaning the inside of the wheel housings.
- Always follow the manufacturer's instructions when using cleaning agents.

WARNING

Dirty, foggy, or icy door windows reduce visibility and can impair the vehicle's safety equipment. This can cause accidents and serious or fatal injuries.

- Only drive when there is clear visibility through all windows.
- Do not use water-repellent window solutions on the windshield. This can cause intense glare under poor visual conditions.

WARNING

Care products can be poisonous, highly flammable and dangerous. Using care products incorrectly or using unsuitable care products can cause burns and poisoning and may lead to accidents and serious or fatal injuries.

- Note the package insert.
- Only store care products in their sealed original containers.
- Keep children away from all care products.
- Only use care products outside or in well-ventilated areas so that no harmful vapors are inhaled.
- Never use turpentine, engine oil, fuel, nail polish remover, or other highly volatile fluids for vehicle care.

NOTICE

Cleaning dirt with aggressive and solvent-based products can cause permanent damage to vehicle equipment, for example even with only brief exposure on seat cushions or decorative parts.

- Do not allow dirt to dry.
- Have stubborn spots removed by a suitably qualified, authorized Volkswagen dealer or authorized Volkswagen Service Facility.

Washing the vehicle

 Please read the introductory information and heed the Warnings and Notice ⇒  and  Vehicle care information.

Washing your vehicle regularly prevents exposure to contamination, which may damage the paint.

Matte-finish vehicles require special care due to the particular properties of the paint.

To ensure that your vehicle is washed correctly and appropriately, note the following information ⇒  , ⇒ .

WARNING

After the vehicle has been washed, the braking efficiency may be delayed due to damp or (in the winter) icy brake discs and brake pads. This will increase the braking distance. This can cause a loss of vehicle control, accidents, and serious or fatal injuries.

- Press the brake pedal carefully several times to dry the brakes and clear the ice from them, as long as the visibility, weather, road, and traffic conditions permit.

NOTICE

Improper car washes can increase the risk of severe vehicle damage.

- Always follow the steps described for vehicle care and cleaning.
- Always follow the manufacturer's instructions.
- Do not wash the vehicle in direct sunlight.

NOTICE

Wet vehicle components may freeze in cold weather, which will stop them from working properly.

- In cold weather, never direct a jet of water at locks, doors, or the trunk lid.

Removing stubborn dirt on matte paint

- Soak insects or bird excrement that have adhered to the surface immediately with water and spray with a special cleaner for matte paint.
- Remove tar splashes on the paint surface with commercially available tar removers. Residue must not be removed by intensive rubbing.
- Remove tree resin and rust particles with special cleaner for matte paint and a cleaning clay bar. Slide the cleaning clay bar over the affected areas without pressing down on it.
- Spray grease and fingerprints with matte paint finish spray and rub with a soft microfiber cloth.

Automatic car washes

- If your vehicle has matte paint, never select a wash program with wax or drying aids.
- If your vehicle has matte paint, only use textile car washes, never brush car washes.
- For vehicle with decorative and protective decals, never use a wash package with hot wax.
- Choose car washes without brushes.
- Also ensure that the underside of the vehicle is washed regularly and thoroughly to remove any residue.
- Observe the information provided by the car wash operator, particularly with regard to attachments on the vehicle, e.g. spoilers ⇒ .

✓ The windows are closed and the outside mirrors are folded in.

✓ The vehicle must be in roll mode.

The electronic parking brake is switched off.

✓ Vehicles with steering lock: If the vehicle is mechanically towed in the car wash, the steering must not be locked ⇒ *Steering information*.

✓ The windshield wiper ⇒ *Window wipers* and the rain/light sensor ⇒ *Rain/light sensor* are switched off.

✓ Auto Hold is switched off.

✓ If applicable: the roof antenna has been removed.

NOTICE

Car washes which mechanically scan contours may damage the vehicle and attachments, e.g. spoiler.

- Follow the information provided by the car wash operator, especially if there are attachments on the vehicle.

Pressure washers



Fig. 178 Warning sign: Do not use pressure washers in the marked area.

- Never use rotating nozzles. Observe the manufacturer's instructions.
- Only use water up to maximum +60 °C (+140 °F).
- Move the water jet evenly with a distance of at least 50 cm (20 inches) between the spray nozzle and all parts of the vehicle.
- Do not direct the water at the same spot for a long period of time.
- If possible, do not direct the water straight at sensitive vehicle components, e.g. rubber seals, side windows, glossy trims, tires, sensors, camera lenses, decorative and protective decals.
- Never clean icy or snow-covered door windows with a pressure washer.

Hand washing

Individual contaminations on the paint can be removed with a cleaning clay bar.

1. Clean dust and large dirt deposits from the vehicle with plenty of water.
2. If your vehicle has matte paint, remove insects, grease spots and fingerprints with a special cleaner for matte paint. Apply the product using a microfiber cloth with gentle pressure.
3. Clean the vehicle with a soft sponge, a washing glove, or a washing brush with light pressure. Start at the roof, and continue to work from the top down. Only use a cleansing shampoo on stubborn dirt.

If your vehicle has matte paint, clean from top to bottom with a neutral cleansing shampoo and a microfiber cloth. Wash the microfiber cloth thoroughly at frequent intervals.
4. Clean the wheels and side members with a clean sponge.
5. Rinse with plenty of water.
6. Let the vehicle air dry. Remove water residue with a leather cloth.

Notes on the high-voltage system

Before washing the vehicle, end the charging process and fully close the charging socket.

Pay attention to the safety warning for the pressure washer ⇒ ⚠.

⚠ WARNING

Using a pressure washer incorrectly may damage the high-voltage system and the 12 V vehicle electrical system. This can cause accidents and serious injuries or death.

- Never point the jet of the pressure washer directly at the orange high-voltage cables, at components of the high-voltage system or at the 12 V vehicle electrical system.

ⓘ NOTICE

Washing the vehicle incorrectly can damage the paint surface and destroy the matte paint finish.

- Never use washing programs with wax treatment.
- Only use cleaning agents free of solids and abrasives, such as cleansing shampoos or insect removers, for cleaning purposes.
- Do not use insect sponges or rough sponges.

! NOTICE

The plenum chamber drain can be blocked by leaves and dirt. Water that cannot drain may leak into the vehicle interior and cause damage.

- Remove leaves and other loose objects with a vacuum or by hand.
- Have the area under the perforated cover cleaned at regular intervals by an authorized Volkswagen dealer or authorized Volkswagen Service Facility.
- Ensure that large amounts of water do not collect in the plenum chamber, for example if you use a pressure washer.

 Only wash the vehicle in facilities specifically designed for that purpose. This will reduce the risk of water contaminated with oil from entering the sewer system.

Exterior care and cleaning

 Please read the introductory information and heed the Warnings and Notice ⇒  and  Vehicle care information.

The following overview gives recommendations for cleaning and caring for individual vehicle components.

! NOTICE

Incorrect cleaning and care can cause vehicle damage.

- Always follow the manufacturer's instructions.
- Never use cleaning objects that are too hard or abrasive.

Door windows, glass surfaces

- Remove wax residue, for example from care products, with a suitable glass cleaner or the Volkswagen Genuine cleaning cloth.
- Remove snow with a hand brush.
- Remove ice with a plastic scraper. When doing so, scrape in one direction only.
- Defrost the ice with a suitable deicer or Volkswagen Genuine deicer.
- Clean wiper blades or change them if necessary.

Paint

Always treat surfaces with extreme care to prevent paint damage.

- Treat light contaminants, for example deposits, insects, and cosmetics, immediately with a clean soft towel and a mild soap solution of maximum two tablespoons of neutral soap in a liter of water, or with a cleaning clay bar.
- Dampen rust spots with soap solution. Then remove with a cleaning clay bar.
- Have corrosion removed by suitably qualified professionals. Volkswagen recommends contacting an authorized Volkswagen dealer or authorized Volkswagen Service Facility.
- In the event of paint damage, consult suitably qualified professionals and have the paint damage repaired. Volkswagen recommends contacting an authorized Volkswagen dealer or authorized Volkswagen Service Facility.

A preservation treatment protects the vehicle paint. When water no longer clearly beads up and drips off *clean* vehicle paint, the vehicle should be retreated with a wax protectant if not earlier.

- For **matte paint**, use a soft sponge to apply a special wax for matte paint to the cleaned vehicle. Remove excess wax with a microfiber cloth.
- Even if a wax protectant is applied regularly in an automatic car wash, Volkswagen recommends protecting the vehicle paint at least twice a year with a suitable hard wax or Volkswagen Genuine hard wax.
- Polishing is only needed if the appearance of the vehicle paint is poor and a shiny finish can no longer be achieved using protectants.

Never polish matte-finish surfaces. The surface will be permanently damaged by the paint shining.

Plenum chamber, hood space

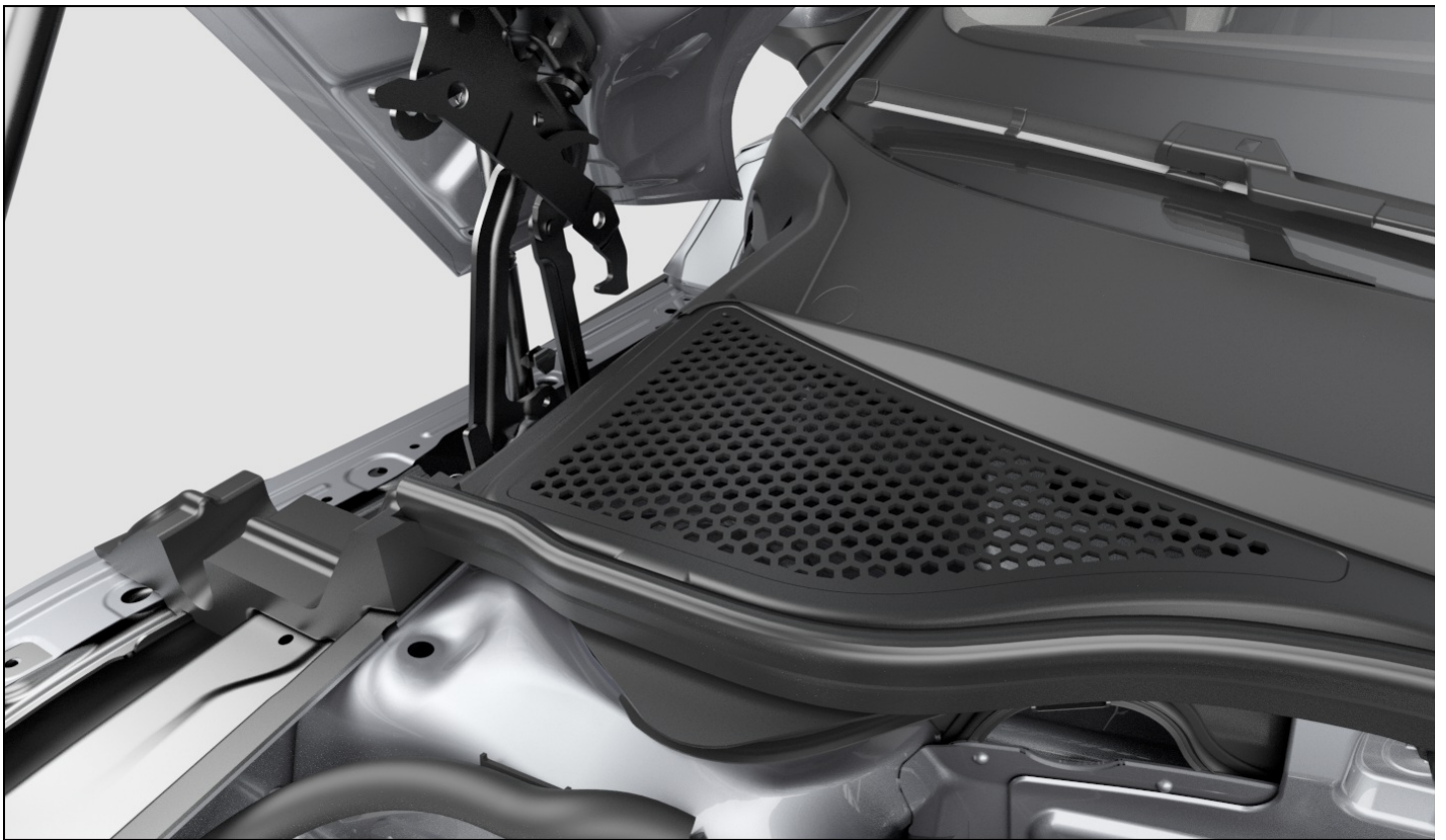

Fig. 179 Between the hood space and windshield: Plenum chamber (general example).

⚠ WARNING

Working in the hood space carries a risk of accident and fire. Serious injuries may occur.

- Always note the necessary handling guidelines and the safety precautions every time before working in the hood space → page , *Safety precautions for working in the hood space*.
- If you are not familiar with this type of work, arrange for it to be done by an authorized Volkswagen dealer or authorized Volkswagen Service Facility. Volkswagen recommends contacting an authorized Volkswagen dealer or authorized Volkswagen Service Facility.

ⓘ NOTICE

The plenum chamber drain can be blocked by leaves and dirt. Water that cannot drain may leak into the vehicle interior and cause damage.

- Have the area under the perforated cover regularly cleaned by an authorized Volkswagen dealer or authorized Volkswagen Service Facility qualified in this respect. Volkswagen recommends contacting an authorized Volkswagen dealer or authorized Volkswagen Service Facility.
- Remove leaves or other loose objects with a vacuum or by hand *fig. 179* , ⇒ **⚠**.
- Always have the hood space cleaned by an authorized Volkswagen dealer or authorized Volkswagen Service Facility qualified in this respect. Volkswagen recommends contacting an authorized Volkswagen dealer or authorized Volkswagen Service Facility.

Water introduced manually into the plenum chamber, for example with a pressure washer, can cause considerable vehicle damage.

Sensors, camera lenses



Fig. 180 In the rear of the vehicle: Rear View Camera system on the handle (general example).

- Clean the area in front of the sensors or the camera with a soft cloth and solvent-free cleaning solution.
- Clean sensitive surfaces of the rain/light sensor and the camera window on the windshield as you would **windows and glass surfaces** (depending on the equipment).
- Remove snow with a hand brush.
- Never use warm or hot water.
- Defrost the ice with a suitable deicer or Volkswagen Genuine deicer.

Decorative and protective decals

- Remove contaminants as described for **paint**. For matte decorative decals, use a suitable plastic cleaner or a Volkswagen Genuine plastic cleaner.
- Treat the vehicle every three months with liquid hard wax. The vehicle must be free of dirt and dust before treating. Apply using only clean, soft microfiber cloths. **Do not use hot wax**, even in a car wash.
- Hard contaminants: remove gently with ethyl alcohol and then wash with warm water.

i The durability and coloring on decorative and protective decals can be affected by environment conditions, such as sunlight, moisture, air pollution, stone chips, etc. Decorative decals may show signs of wear and aging after approximately one to three years, and protective decals after approximately two to three years. In very hot climates, the decorative decals may fade slightly within one year and the protective decals within two years.

Trims made out of chrome-plated plastic, aluminum or stainless steel

- Clean surfaces with a suitable chrome and aluminum product or Volkswagen Genuine chrome and aluminum products.
- Chrome-plated trims can be protected with a suitable hard wax or Volkswagen Genuine hard wax.

Headlights, taillights

- Use a soft sponge saturated with a mild soap solution of maximum two tablespoons of neutral soap in a liter of water to remove dirt. Do not use cleaning solutions containing alcohol and/or solvents.
- Remove stubborn dirt with a suitable chrome and aluminum product or Volkswagen Genuine chrome and aluminum products.

Wheels

- Remove contaminants and road salt with plenty of water.
- Clean dirty alloy wheels with a suitable rim cleaner or with Volkswagen Genuine rim cleaner. Volkswagen recommends applying a suitable hard wax or Volkswagen Genuine hard wax to the rims every three months.
- Repair a damaged protective paint layer immediately with a paint pen. If necessary, contact an authorized Volkswagen dealer or authorized Volkswagen Service Facility. Volkswagen recommends contacting an authorized Volkswagen dealer or authorized Volkswagen Service Facility.
- Remove brake dust with a suitable rim cleaner or Volkswagen Genuine rim cleaner.

Door lock cylinder

1. Defrost the door lock cylinder with a suitable door lock deicer or Volkswagen Genuine deicer.
Do not use any door lock deicers with degreasing substances.

Care and cleaning of the vehicle interior

i Please read the introductory information and heed the Warnings and Notice ⇒ **!** and **!** Vehicle care information.

The following overview gives recommendations for cleaning and caring for individual vehicle components.

! NOTICE

Incorrect cleaning and care can cause vehicle damage.

- Always follow the steps described for vehicle care and cleaning.
- Do not use steam cleaners, brushes, hard sponges, etc.
- Have tough spots removed by an authorized Volkswagen dealer or authorized Volkswagen Service Facility.

Door windows

- Clean the door window with a glass cleaner.
- Wipe the door windows dry with a clean chamois or a lint-free cloth.

Textiles, microfiber, leatherette

- Regularly remove dirt particles that adhere to the surface with a vacuum cleaner so that the material is not permanently damaged by scrubbing.
- Remove contaminants with a suitable interior cleaner or Volkswagen Genuine interior cleaner.
- For grease-based contaminants such as oil, use a suitable interior cleaner or Volkswagen Genuine interior cleaner. Blot away the dissolved grease or dye with an absorbent towel. If necessary, treat afterwards with water.
- For contaminants, for example from pens or nail polish, use a suitable interior cleaner or Volkswagen Genuine interior cleaner. If necessary, treat afterward with a mild soap solution of maximum two tablespoons of neutral soap in a liter of water.
- Never use leather cleaners, solvents, floor polish, shoe polish, paint remover, or other similar substances.
- Never use pressure washers, steam cleaners or cooling sprays.

Natural leather

- Remove fresh dirt with a cotton cloth and a mild soap solution of maximum two tablespoons of neutral soap in a liter of water. Do not let any fluids seep into the cracks.
- For contaminants, for example from pens or nail polish, use a suitable leather cleaner or Volkswagen Genuine leather cleaner.
- Treat dried spots with a suitable leather cleaner or with Volkswagen Genuine leather cleaner.
- Remove any fresh spots of grease such as oil with an absorbent cloth.
- Apply leather care to seats regularly and each time you clean. If leaving the vehicle parked for long periods of time, you should cover the leather to protect it from direct sunlight.

Never treat leather with solvents, floor polish, shoe polish, paint remover, or other similar substances.

Plastic parts

- Clean with a soft, damp cloth.
- If a mild soap solution of maximum two tablespoons of neutral soap in a liter of water cannot remove stubborn stains, use a solvent-free plastic cleaner or Volkswagen Genuine plastic cleaner, if necessary.

Trims, decorative trims made out of chrome, aluminum or stainless steel

- Clean using a clean, soft towel and mild soap solution of maximum two tablespoons of neutral soap in a liter of water, in a dust-free area.
- Treat anodized surfaces with a suitable chrome and aluminum product or Volkswagen Genuine chrome and aluminum products.

Controls

1. Use a soft brush to remove large dirt deposits as well as any dirt that is difficult to reach.
2. Use a clean, soft cloth and a fairly mild soap solution of maximum two tablespoons of neutral soap in a liter of water. Fluids must not enter into the controls.

Displays and screens

Do not clean the instrument cluster display and the Infotainment system screen when they are dry.

1. Turn off the Infotainment system temporarily to clean it.
2. Use a suitable cleaning cloth or Volkswagen Genuine cleaning cloth with some water, suitable glass cleaner, or an LCD cleaner.

Rubber seals

- Clean with a soft, lint-free cloth and plenty of water.
- Treat regularly with a suitable rubber care product or Volkswagen Genuine rubber care product.

Safety belts

1. Unreel the safety belt completely and leave the belt unreeled.

2. Remove large spots of dirt with a soft brush.
3. Clean the safety belt with a mild soap solution of maximum two tablespoons of neutral soap in a liter of water.
4. Let the belt webbing dry completely, then allow the belt to retract.

WARNING

Improper cleaning of safety belts, anchorages and automatic safety belt retractors can cause damage and impair their function. This may result in serious injuries or death in the event of an accident.

- Never alter the safety belts for cleaning purposes.
- Never use chemical products to clean the safety belts and their components.
- Do not use any corrosive fluids, solvents, or sharp objects.
- Do not allow fluids and objects to enter the safety belt buckle.
- Let the safety belt dry after cleaning before allowing it to retract completely.

Wood trims

Clean with a soft cloth and fairly mild soap solution of maximum two tablespoons of neutral soap in a liter of water.

Cleaning the seat covers

If dye from clothing such as denim stains the seat covers, this is not considered a defect in the vehicle upholstery. If you want to clean the seat covers yourself, be aware that airbag system components and electrical connectors are installed in the seat covers. Incorrect cleaning or moisture may damage these components or cause them to malfunction. This may then cause damage elsewhere in the vehicle's electrical system ⇒ .

Depending on the equipment, electrical components and connectors may be installed in the seat surface with seat heating, which can be damaged by incorrect cleaning or handling. This can also result in damage to other areas of the vehicle electrical system.

- Never use pressure washers, steam cleaners or cooling sprays.
- Never soak seat covers.
- Never switch on seat heating to dry the seats.
- Do not use detergent pastes or mild detergent solutions.
- If there is uncertainty, contact suitably qualified professionals for assistance. Volkswagen recommends contacting an authorized Volkswagen dealer or authorized Volkswagen Service Facility.

WARNING

Cleaning and caring for vehicle components incorrectly can irreparably damage and impair the vehicle's safety equipment, such as the airbag modules. This may cause serious injuries in the event of an accident.

- Always use approved or recommended cleaning solution.
- Never use cleaning solutions that contain solvents.
- Clean and maintain vehicle components only according to the manufacturer's instructions.

 **Needless to say, it is easier to see signs of wear and dirt caused by normal usage on bright materials in the vehicle interior. These signs of use are unavoidable and also indicate the unavoidable deterioration caused by normal usage. Please follow the corresponding care instructions.**

Accessories, replacement parts, repairs, and modifications

Accessories and replacement parts

Consult an authorized Volkswagen dealer or authorized Volkswagen Service Facility before purchasing Genuine Volkswagen Accessories, replacement parts, or operating equipment, for example if you would like to retrofit the vehicle with Genuine Volkswagen Accessories or if parts need to be replaced. The authorized Volkswagen dealer or authorized Volkswagen Service Facility is aware of legal regulations and factory recommendations for Genuine Volkswagen Accessories, replacement parts, and operating equipment. Volkswagen recommends contacting an authorized Volkswagen dealer or authorized Volkswagen Service Facility.

Volkswagen recommends the use of Volkswagen original parts or Volkswagen original accessories, which you can acquire from an authorized Volkswagen dealer or authorized Volkswagen Service Facility. Volkswagen has verified their reliability, safety, and suitability. A suitably qualified authorized Volkswagen dealer or authorized Volkswagen Service Facility also specializes in correct installation. Volkswagen recommends contacting an authorized Volkswagen dealer or authorized Volkswagen Service Facility.

Products that are not approved by Volkswagen may not have been evaluated by Volkswagen regarding the reliability, safety, and suitability for the vehicle, despite ongoing market observation. Therefore, Volkswagen can also not be responsible in individual cases if approval is given by an officially-recognized technical inspection and control authority or clearance is given by a government agency.

You must consult a suitably qualified authorized Volkswagen dealer or authorized Volkswagen Service Facility to replace rim/tire combinations. Volkswagen recommends contacting an authorized Volkswagen dealer or authorized Volkswagen Service Facility.

Retrofitted devices that have a direct effect on vehicle control, must have an **e** symbol (the approval symbol for the European Union) and be approved by Volkswagen for the vehicle. Such devices could include a cruise control system or an electronically-controlled damping system.

Additional electrical devices that do not have a direct effect on vehicle control must have a **a** symbol (manufacturer's Declaration of Compliance for the European Union). Such devices could include refrigerators, computers, or ventilators.

WARNING

Using unsuitable replacement parts and accessories may lead to malfunctions in the vehicle. These problems may also occur if work, modifications and repairs are done incorrectly. This could lead to damage to the vehicle and accidents resulting in serious or fatal injuries.

- Only have suitably qualified professionals make repairs or modifications to a vehicle. Authorized Volkswagen dealers and authorized Volkswagen Service Facilities have the required tools, diagnostic devices, repair information, and qualified personnel. Volkswagen recommends contacting an authorized Volkswagen dealer or authorized Volkswagen Service Facility.
- Only install parts on the vehicle whose design and function are identical to the parts installed at the factory.
- Only use rim/tire combinations that are approved by Volkswagen for your vehicle model.

WARNING

Objects in the airbag deployment zone may be thrown around the vehicle interior if the airbags deploy. This can cause serious or fatal injuries.

- Never attach or position objects in the airbag deployment zone.

Sensors and Cameras

The sensors or cameras could shift or become damaged as a result of incorrect repairs, structural changes to the vehicle (such as "lowering"), installation of after-market equipment, or changes to the trim panels. This may impair important functions in the driver assistance systems → .

- Note the positions of sensors and cameras on your vehicle in the vehicle overviews.

Attachments or Modifications around Sensors and Cameras

WARNING

If the area in front of and around sensors and cameras is covered, for example by license plates, decorative frames for license plate holders, additional films that have been attached, or paint on the sensors, etc., this can impair the functions of the driver assistance systems. Failure of the driver assistance systems may result in accidents and serious or fatal injuries.

- Do not stick additional films over or around sensors.
- Only install a license plate or decorative frame for license plate holders in the position specified. Always consult an authorized Volkswagen dealer or authorized Volkswagen Service Facility if you want to install a license plate or decorative frame for a license plate holder on the vehicle. Volkswagen recommends contacting an authorized Volkswagen dealer or authorized Volkswagen Service Facility.

NOTICE

Incorrectly installing license plates or decorative frames for license plate holders may damage vehicle components, such as wires or sensors.

- Only install a license plate or decorative frame for license plate holders in the position specified. Always consult an authorized Volkswagen dealer or authorized Volkswagen Service Facility if you want to install a license plate or decorative frame for a license plate holder on the vehicle. Volkswagen recommends contacting an authorized Volkswagen dealer or authorized Volkswagen Service Facility.

Decorative frames for license plate holders are designed for holding the license plate.

The Volkswagen emblem can impede the view of the radar sensors to the front on some vehicle versions. Therefore only operate the vehicle with the original Volkswagen emblem or an emblem approved by Volkswagen.

Damage around Sensors and Cameras

WARNING

If the area around sensors and cameras is damaged, for example due to stone chips or collisions when parking, this may impair the functions of the driver assistance systems. Failure of the driver assistance systems may result in accidents and serious or fatal injuries.

- If there is damage in the area of the sensors and cameras, have the component replaced by a suitably qualified professional. Volkswagen recommends contacting an authorized Volkswagen dealer or authorized Volkswagen Service Facility.

After components have been replaced, it may be necessary for sensors and cameras to be set and calibrated by an authorized Volkswagen dealer or authorized Volkswagen Service Facility. Volkswagen recommends contacting an authorized Volkswagen dealer or authorized Volkswagen Service Facility.

If the windshield is damaged within the sensors' and camera's range, for example by a stone chip, then the windshield must be replaced. Stone chip repairs can cause malfunctions in the driver assistance system. After the windshield has been replaced, it may be necessary for the camera and sensors to be set and calibrated by an authorized Volkswagen dealer or authorized Volkswagen Service Facility. Volkswagen recommends contacting an authorized Volkswagen dealer or authorized Volkswagen Service Facility.

Repairs and technical modifications

Volkswagen guidelines must be followed when performing repairs and technical modifications ⇒ ⚠.

Interference with electronic components and their software can cause malfunctions. Because of the way electronic components are interconnected, such malfunctions can also impair systems that are not directly involved. This means that you risk both a substantial reduction in the operational safety of your vehicle and increased wear of vehicle components.

An authorized Volkswagen dealer or authorized Volkswagen Service Facility cannot assume any liability for damage resulting from repairs and technical modifications that were performed incorrectly.

An authorized Volkswagen dealer or authorized Volkswagen Service Facility is not responsible for damage resulting from repairs and technical modifications that were performed incorrectly. Such damages are also not covered by the Volkswagen warranty.

Have all repairs and technical modifications performed by suitably qualified professionals. Volkswagen recommends contacting your authorized Volkswagen dealer or authorized Volkswagen Service Facility for Volkswagen Genuine Parts®.

Volkswagen repair information

Volkswagen service information and official Volkswagen repair information can be purchased.

Customers in Europe, Asia, Australia, Africa, Central and South America:

Contact suitably qualified professionals for assistance. Volkswagen recommends contacting an authorized Volkswagen dealer or authorized Volkswagen Service Facility. Or register with the **erWin** (electronic repair and service information) web portal:

<https://erwin.volkswagen.de>

Customers in North America and Canada:

If you wish to order the printed service information, please contact:

Volkswagen Technical Literature Ordering Center literature.vw.com

You can also register for the **erWin** web portal:

<https://erwin.vw.com>

Diagnostic connection (on-board diagnosis)

In the vehicle interior, there is a diagnostic connection (OBD) to read event memories. Event memories document faults that have occurred and deviations from specified values from the control module ⇒ ⚠.

The diagnostic connection (OBD) is located in the footwell on the driver's side on the underside of the instrument panel or next to the hood release lever behind a cover.

Only have the event memory read out and reset by suitably qualified professionals. Additional information about the saved data can be obtained from suitably qualified professionals. Volkswagen recommends contacting an authorized Volkswagen dealer or authorized Volkswagen Service Facility.

After a malfunction is fixed, the information about it will be deleted from the event memory. Other memory content is overwritten continuously.

Vehicles with special modifications and mountings

The attachment and mounting manufacturer should make sure that the applicable environmental laws and regulations are met for the attachments and mountings, especially the EU directive 2000/53/EG about old vehicle and EU directive 2003/11/EG about market introduction restrictions and the use of certain hazardous materials and compounds.

The installation instructions for any retrofitted equipment should be saved by the vehicle owner and provided to the removal facility if the vehicle is scrapped. This ensures that even vehicles with retrofitted equipment will be disposed of in a way that will not harm the environment.

Engine/motor protection

Engine/motor protection can reduce the risk of damage to the vehicle underbody, for example if driving over curbs, entering driveways, or on unpaved roads.

Have the retrofitting work performed by suitable qualified professionals. Volkswagen recommends contacting an authorized Volkswagen dealer or authorized Volkswagen Service Facility.

Engine/motor protection may not be available in all countries.

⚠ WARNING

Repairs and modifications to the vehicle that are performed incorrectly can impair the effectiveness of the driver assistance systems and deploying airbags. This can cause malfunctions and accidents and serious injuries or death.

- Only have suitably qualified professionals make repairs or modifications to a vehicle. Volkswagen recommends contacting an authorized Volkswagen

dealer or authorized Volkswagen Service Facility.

WARNING

Repairs and modifications to the vehicle that are performed incorrectly, for example due to the use of unsuitable parts, may cause vehicle damage, accidents, and serious or fatal injuries.

- Only install parts on the vehicle whose design and function are identical to the parts installed at the factory.
- Only use rim/tire combinations that are approved by Volkswagen for your vehicle model.
- Only have suitably qualified professionals make repairs or modifications to a vehicle. Volkswagen recommends contacting an authorized Volkswagen dealer or authorized Volkswagen Service Facility.
- Volkswagen recommends the use of Volkswagen original parts or Volkswagen original accessories. Volkswagen has verified their reliability, safety, and suitability.

WARNING

Incorrect use of the diagnostic connection may cause malfunctions, resulting in accidents and serious or fatal injuries.

- Never read out the event memory yourself using the diagnostic connection.
- Never load data yourself using the diagnostic connection in the vehicle.
- Only have the event memory read out with the diagnostic connection by suitably qualified professionals. Volkswagen recommends contacting an authorized Volkswagen dealer or authorized Volkswagen Service Facility.

Airbag system repairs and situations that can affect the system function

Volkswagen guidelines must be followed when performing repairs and technical modifications ⇒ .

Only have modifications and repairs on the front bumper, doors, front seats, headliner, or vehicle body performed by an authorized Volkswagen dealer or authorized Volkswagen Service Facility. Volkswagen recommends contacting an authorized Volkswagen dealer or authorized Volkswagen Service Facility. Airbag system components and sensors may be located on these vehicle components.

Airbag system components can be damaged during all procedures on the airbag system and when removing and installing system components while performing other repair procedures. This may prevent the airbags from deploying or cause them to deploy incorrectly in the event of an accident.

The instructions must be followed so that the effectiveness of the airbags is not impaired and removed components do not cause injuries and environmental pollution. An authorized Volkswagen dealer or authorized Volkswagen Service Facility will be familiar with these provisions. Volkswagen recommends contacting an authorized Volkswagen dealer or authorized Volkswagen Service Facility.

A modification to the vehicle suspension can impair the functionality of the airbag system during a collision. For example, using a rim/tire combination that is not approved by Volkswagen, lowering the vehicle, or changing the suspension stiffness including the springs, suspensions struts, shock absorbers, etc., can change the force that is measured by the airbag sensors and transmitted to the electronic control module. For example, some changes to the suspension can increase the force measured by the systems and trigger the airbag system in accidents where the airbags would normally not be deployed if the modifications had not been made. Other modifications can reduce the force measured by the sensors and prevent the airbag from deploying when it should have deployed.

WARNING

Using unsuitable replacement parts and accessories may cause damage and malfunctions in the vehicle and impair the effectiveness of the airbag system. These problems may also occur if work, modifications and repairs are done incorrectly. This could lead to damage to the vehicle and accidents resulting in serious or fatal injuries.

- Only have suitably qualified professionals make repairs or modifications to a vehicle. Authorized Volkswagen dealers and authorized Volkswagen Service Facilities have the required tools, diagnostic devices, repair information, and qualified personnel. Volkswagen recommends contacting an authorized Volkswagen dealer or authorized Volkswagen Service Facility.
- Note that the airbag module cannot be repaired but must instead be replaced.
- Never install airbag components removed from old vehicles or from recycling.
- Only install parts on the vehicle whose design and function are identical to the parts installed at the factory.

WARNING

Modifications to the vehicle suspension including using a rim/tire combination that is not permitted may change the system function of the airbag. This can cause serious or fatal injuries in the event of an accident.

- Never install suspension components that do not have the same properties as the original parts installed in the vehicle.
- Never use rim/tire combinations that are not approved by Volkswagen.

Mobile phone usage in the vehicle

Electromagnetic waves

When using a mobile phone or radio equipment without connecting to the exterior antenna, the electromagnetic waves will not be deflected outward in an optimum way. Increased waves in the vehicle interior can occur, especially when reception is poor, for example in rural areas. This could be a potential health risk ⇒ ⚠.

Depending on the equipment, it may be possible to use a suitable telephone interface to connect the mobile phone to the exterior antenna. This will improve the connection quality and increase the range.

Using a phone

In many countries, using a phone in the vehicle is only permitted if there is a hands-free connection, for example using a Bluetooth[®] connection. Before using the phone, secure it in a suitable holder ⇒ ⚠ or store it in a storage compartment, such as in the center console, to prevent it from sliding around.

Radio

If operating radio devices, follow the legal regulations and the user guide from the manufacturer. The aftermarket installation of radio devices is subject to approval.

Contact qualified professionals for more information about installing radio equipment. Volkswagen recommends contacting an authorized Volkswagen dealer or authorized Volkswagen Service Facility.

WARNING

Mobile devices that are loose or not secured correctly can be thrown through the vehicle interior during sudden driving or braking maneuvers or in the event of a collision and cause severe injuries.

- Secure or store the mobile phone and accessories safely and outside of the deployment range of the airbags.

WARNING

Using a cell phone or radio equipment without a connection to an external aerial may create electromagnetic energy inside the vehicle that exceeds permissible limits. This also applies if the exterior antenna is not installed correctly. This may be dangerous to your health and that of the other vehicle occupants.

- Maintain a minimum distance of approx. 20 cm (approx. 8 inches) between the device antennae and any active medical implants, such as pacemakers.
- Do not carry a mobile device that is turned on directly above or in the immediate vicinity of any active medical implants, for example by keeping a phone in a shirt pocket.
- Switch off the mobile device immediately if you suspect there is interference with an active medical implant or other medical device.

Customer information

Warranty

Warranty

Garantie

Your vehicle is covered by various warranties:

- New Vehicle Limited Warranty.
- Limited Warranty Against Corrosion Perforation.
- Emissions Control System Warranties: Federal Emissions Control System Defect Warranty, Federal Emissions Performance Warranty.
- US battery electric vehicles: High-Voltage System Limited Warranty.
- US models: Kansas Safety Belt Limited Warranty.
- US models: California Emissions Control System Warranties: Short-term Emissions Defects Warranty, Long-term Emissions Defect Warranty, California Emissions Performance Warranty.

You can find the detailed information in your Warranty & Maintenance Booklet and California Emissions Booklet or on the website:

maintenance.vw.com

Warranty for the high-voltage battery for electric and hybrid vehicles

In addition to the warranties and guarantees mentioned above, authorized Volkswagen dealers or authorized Volkswagen Service Facilities also comply with the general warranty for high-voltage batteries that applies in many countries.

Please find details of the warranty conditions in your sales contract or contact your authorized Volkswagen dealer or authorized Volkswagen Service Facility.

Event data recorder (crash data recorder)

This vehicle is equipped with an event data recorder (EDR). The main purpose of an EDR is to record, in certain crash or near crash-like situations, such as an air bag deployment or hitting a road obstacle, data that will assist in understanding how a vehicle's systems performed. The EDR is designed to record data related to vehicle dynamics and safety systems for a short period of time, typically 30 seconds or less. The EDR in this vehicle is designed to record such data as:

- How various systems in your vehicle were operating;
- Whether or not the driver and passenger safety belts were buckled/fastened;
- How far (if at all) the driver was depressing the accelerator and/or brake pedal; and,
- How fast the vehicle was traveling.

These data can help provide a better understanding of the circumstances in which crashes and injuries occur.

In addition, data from the driver assistance systems is also collected. In addition to information about whether these systems were switched on or off, had limited availability, or were inactive, it can also be understood if these functions steered, accelerated, or braked the vehicle in the situations listed above. Depending on the vehicle equipment, systems may include:

- Adaptive Cruise Control (ACC).
- Lane Assist
- Park Assist
- Parking systems
- Autonomous Emergency Braking Function (Front Assist)

NOTE: EDR data are recorded by your vehicle only if a non-trivial crash situation occurs; no data are recorded by the EDR under normal driving conditions and no personal data (e.g., name, gender, age, and crash location) are recorded. However, other parties, such as law enforcement, could combine the EDR data with the type of personally identifying data routinely acquired during a crash investigation.

To read data recorded by an EDR, special equipment is required, and access to the vehicle or the EDR is needed. In addition to the vehicle manufacturer, other parties, such as law enforcement, that have the special equipment, can read the information if they have access to the vehicle or the EDR.

Volkswagen will not access, read or process the Event Data Recorder (EDR) data unless the vehicle owner gives permission. This excludes contractual or legal regulations.

Due to the legal obligation to monitor products, Volkswagen is allowed to use data for field observation as well as for research purposes and quality improvement of vehicle safety systems. For research purposes, Volkswagen provides the data to third parties in an anonymous format. This means the data does not reference the individual vehicle or the vehicle owner.

Labels and signs

Factory-installed labels and signs with important information regarding vehicle operation are located in the hood space and on several vehicle components.

- Never remove these labels and signs or make them illegible.
- If vehicle components equipped with labels and signs are replaced, suitably qualified professionals must place identical labels and signs correctly in the same locations on the new components. Volkswagen recommends contacting an authorized Volkswagen dealer or authorized Volkswagen Service Facility.

Safety certificate

A safety certificate on the driver's door jamb specifies all necessary safety standards and guidelines of the traffic safety authorities in the applicable country at the time of manufacture. The month and year of production as well as the VIN may also be listed. Read the information in the Owner's Manual ⇒ [Safety certificate](#).

High-voltage warning label

There are labels in the vehicle front end and on high-voltage components, including the high-voltage battery, that provide warnings of the high voltage of the vehicle electrical system ⇒ [Warning signs for the high-voltage system](#).

WARNING

Incorrect vehicle handling increases the risk of accidents, serious injuries and death.

- Follow the legal regulations.
- Follow the Owner's Manual instructions.

NOTICE







Incorrect vehicle handling can cause vehicle damage.

- Follow the legal regulations.
- Perform service according to the specifications.

Fluids in the air conditioning system

Refrigerant in the air conditioning system

The label in the hood space provides information about the type and amount of refrigerant used in the vehicle air conditioner. The label is in the front section of the hood space near the refrigerant filler tubes ⇒ .

 **Warning: the air conditioning system must only be serviced by qualified technicians.**  **Refrigerant type.**  **Type of refrigerant oil.**  **See service information (only available for authorized Volkswagen dealers and authorized Volkswagen Service Facilities).**  **The air conditioning system must only be serviced by qualified technicians.**  **Flammable refrigerant.**  **Make sure all components are disposed of correctly and never install components removed from old vehicles or from recycling in the vehicle.**

Refrigerant oil in the air conditioner

The air conditioner is filled with refrigerant oil. The label on the air conditioner compressor provides information on the type and quantity of refrigerant oil used ⇒ [Repairs and technical modifications](#).

WARNING

Air conditioner maintenance by unqualified professionals may pose a danger to safe operation and result in serious injuries.

- Only have the air conditioner serviced by qualified professionals.

NOTICE

Repairing or replacing the evaporator with replacement parts from scrap vehicles or recycled parts may damage the air conditioner.

- Never have repairs to the evaporator carried out with replacement parts from scrap vehicles or recycled parts.
- Only have replacement parts for the air conditioner evaporator fitted that are certified and marked in accordance with SAE standards J2842 HFO-1234y and R744.
- Have the air conditioner serviced only by qualified technicians who are trained according to SAE standard J2845 and certified according to SAE standard J2911. SAE standard J639 must be complied with while working on the air conditioner.
- Have damaged or missing refrigerant labels, e.g. in the engine compartment, replaced.

Infotainment system and aerials

The aerials for the Infotainment system are fitted in various places in the vehicle:

- On the windshield between the layers of glass.

- On the rear window and on the side windows with a printed antenna structure ⇒ .

NOTICE

Antennas that are located on the inside of the window glass can be damaged by abrasive objects or by corrosive and acidic materials.

- Never apply stickers over metal wires, for example on the rear window
- Never clean the antennas with corrosive or acidic materials.

NOTICE

A retrofitted Infotainment system that is incompatible with the antenna amplifier installed in the vehicle by the manufacturer may damage the antenna amplifier.

- Before retrofitting an Infotainment system, contact an authorized Volkswagen dealer or authorized Volkswagen Service Facility. Volkswagen recommends contacting an authorized Volkswagen dealer or authorized Volkswagen Service Facility.

Component protection

Some electronic components and control modules, such as the Infotainment system, are equipped with component protection at the factory.

The component protection allows suitably qualified professionals to legitimately install or replace components and control modules. Volkswagen recommends contacting your Volkswagen dealership.



In the following situations, component protection reduces the risk of components supplied by the factory being operated without restrictions outside the vehicle.

- Installation in other vehicles, for example the components have been stolen
- Operating components outside of the vehicle

If a message about component protection appears in the instrument cluster display or on the Infotainment system screen, contact a suitably qualified professional for assistance. Volkswagen recommends contacting your Volkswagen dealership.

Disposal of old batteries and electronic devices

Old batteries

As with electronic devices, old batteries must be collected and recycled separately by the end user. These batteries are indicated by the crossed-out wheeled garbage can symbol . You, as the end user, are legally obliged to return old batteries ⇒ .

- In many federal states, old batteries can be handed in to an authorized Volkswagen dealer or authorized Volkswagen Service Facility.
- High-voltage batteries can be handed in to an authorized Volkswagen dealer or authorized Volkswagen Service Facility.
- You can obtain more information on return and recycling from your authorized Volkswagen dealer or authorized Volkswagen Service Facility.

Old electrical or electronic devices

Your vehicle contains old electrical/electronic devices, such as the navigation system SD card or remote controls. You can recognize these from the symbol of the crossed-out wheeled garbage can .

Old devices with this marking must be collected separately from normal household garbage and disposed of in accordance with legal requirements.

- Batteries within devices that are not permanently installed must be removed beforehand and disposed of separately as batteries.
- Any saved personal data must be erased before disposal of old devices.

You can obtain more information on return and recycling from your authorized Volkswagen dealer or authorized Volkswagen Service Facility.

WARNING

If batteries containing lithium are damaged, gaseous or liquid substances may escape, posing a significant risk to health and the environment. A short circuit at the battery terminal may result in a fire or explosion. This could result in serious or fatal injuries.

- Take extreme care when handling batteries containing lithium.
- Never heat up lithium-containing batteries.
- Never damage lithium-containing batteries.
- Never short circuit the battery terminals.

 Batteries containing heavy metals are marked with the chemical symbols Hg (mercury), Cd (cadmium) and/or Pb (lead). Heavy metals can be harmful to the health of humans and animals and accumulate in the environment.

- In order to avoid these consequences, it is imperative to ensure you collect batteries separately and return them properly.

🌿 Batteries for the remote control vehicle key and remote controls may contain perchlorate. For information on how to handle these materials correctly, see the following website: www.dtsc.ca.gov/perchlorate. Follow all the legal specifications for dealing with and disposing of these batteries. Volkswagen recommends having these batteries replaced and disposed of by suitably qualified professionals. Volkswagen recommends contacting an authorized Volkswagen dealer or authorized Volkswagen Service Facility.

Product recycling

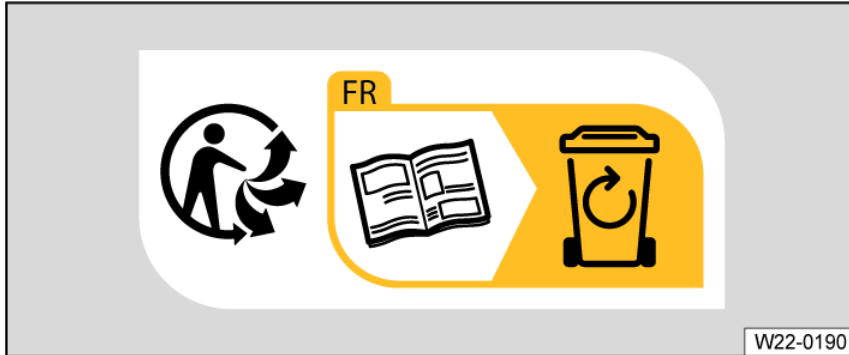

Fig. 181

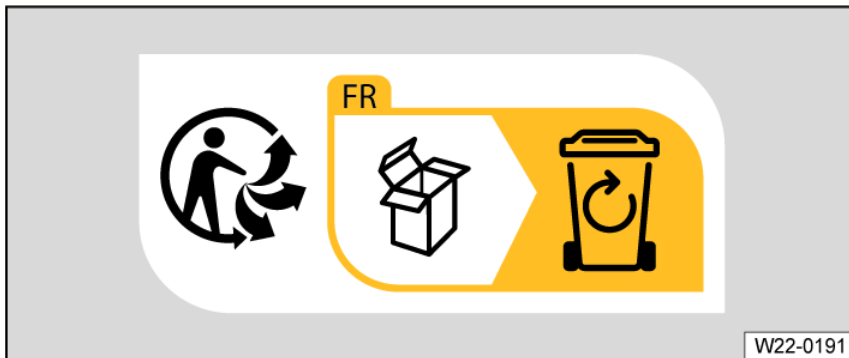

Fig. 182



Fig. 183

🌿 The Triman logo and the Infotri symbol contain important sorting information for the end consumer.

Declaration of conformity (Declaration of Compliance, Telecommunications and Electronic Systems)

Radio Frequency Devices and Radiocommunication Equipment User Manual Notice.

These devices comply with:

FCC Part 15.19

These devices comply with **Part 15 of the FCC Rules**. Operation is subject to the following 2 conditions:

- (1) This device may not cause harmful interference, and
- (2) this device must accept any interference received, including interference that may cause undesired operation.

FCC Part 15.21

CAUTION:

Changes or modifications not expressly approved by the party responsible for compliance could void the user's authority to operate the equipment.

Radio equipment

- Provision for mobile telephone.
- Electronic immobilizer
- Remote start relay function.
- Vehicle key
- Keyless locking and starting system Keyless Access.
- USA: VW Car-Net®.
- Adaptive Cruise Control (ACC)
- Autonomous Emergency Braking (Front Assist).
- Rear Traffic Alert.

Third Party Copyright Information

<https://www.volkswagen.com/softwareinfo>

Some products installed in this vehicle contain software components that are covered under Open Source licenses.

A list of the Open Source software components being used, including copyright information, the relevant Open Source license conditions, and those applicable license texts, are available at the website given above. The source code of specific Open Source software components can be requested from the vehicle manufacturer. The manufacturer will provide the source code in accordance with the relevant license conditions, whereby you will only be charged for the provision costs, e.g. delivery costs. The required information can be obtained at the website given above.

Old vehicle return and scrap disposal

Old vehicle return

At the end of its life cycle, your vehicle should be recycled or disposed of in an environmentally friendly manner. This is why the last owners of vehicles in many states are legally obliged to hand their vehicles over to an authorized treatment facility.

Volkswagen has already made provision for this point: Recycling centers where you can hand over your vehicle are available throughout many federal states.

Find out more information about recycling centers from your authorized Volkswagen dealer or authorized Volkswagen Service Facility.

Scrap disposal

If scrapping the vehicle or its individual parts such as the airbag system and the safety belt pretensioners, the applicable safety regulations must always be followed. Suitably qualified professionals will be familiar with these provisions. Volkswagen recommends contacting your authorized Volkswagen dealer or authorized Volkswagen Service Facility.

Radar Sensors

Depending on the vehicle equipment, assistance systems, e.g. Adaptive Cruise Control (ACC), that use radar sensors may be installed in your vehicle.

Observe the legal regulations for restricted access to certain zones that prohibit entry for vehicles with radar sensors. Observe relevant traffic signs where applicable. If you wish to enter one of these areas, first consult with an authorized Volkswagen dealer or authorized Volkswagen Service Facility to determine whether there are radar sensors installed in your vehicle.

WARNING

Sensors are subject to physical system limitations. External sources of interference, e.g. from other vehicles, can affect the functions of the sensors and impair the functions of the supporting systems. If the system does not work as expected, this may result in accidents and serious or fatal injuries.

- Always pay attention to the traffic situation and vehicle environment.
- Always adapt your speed and driving style to the visibility, weather, road and traffic conditions.

Reporting Safety Defects

If you believe that your vehicle has a defect which could cause a crash or could cause injury or death, you should immediately inform the National Highway Traffic Safety Administration (NHTSA) in addition to notifying Volkswagen of America, Inc.

If NHTSA receives similar complaints, it may open an investigation, and if it finds that a safety defect exists in a group of vehicles, it may order a recall and remedy campaign. However, NHTSA cannot become involved in individual problems between you, your dealer, or Volkswagen of America, Inc.

To contact NHTSA, you may call the Vehicle Safety Hotline toll-free at:

Tel.: 1-888-327-4236 (TTY: 1-800-424-9153)

go to:

<http://www.nhtsa.gov>

or write to:

Administrator, NHTSA, 1200 New Jersey Avenue, SE. Washington, D.C. 20590
You can also obtain other information about motor vehicle safety from

<http://www.safercar.gov>

Notes on radio regulations



Declaration of conformity for radio equipment for the USA

Approval mark for radio systems in the USA.

With this document, the manufacturer declares that the radio equipment listed in the following is in compliance with the basic requirements and other relevant regulations and laws at the time of production:

The radio systems listed below are not available in every vehicle.

- Connection to the exterior antenna
- Antenna
- Antenna amplifier
- Bluetooth®.
- Remote control key (vehicle)
- Garage door opener
- ID. Cockpit.
- Infotainment system
- Keyless Access.
- Instrument cluster, electronic immobilizer
- Radar sensors for assistance systems
- Tire pressure sensors
- Mobile phone interface
- Volkswagen Car-Net control module
- Wi-Fi hotspot.
- Central control module

 **Radio systems with this marking must be collected separately from normal household garbage and disposed of in accordance with legal requirements**
 **Disposal of old batteries and electronic devices.**  **Symbol for limited use of certain hazardous substances in electrical and electronic devices in accordance with the RoHS directive.**

Approval numbers

FCC ID: 2AAJCBR20, FCC ID: 2AAJCBR21, FCC ID: 2AA98, FCC ID: 2AA98-COLOUR5C, FCC ID: 2AA98-MEDIUM5C, FCC ID: 2AA98-MEDIUM5C21, FCC ID: 2AA98A, FCC ID: 2AHPN-WLC, FCC ID: 2AOUZ17101001, FCC ID: 2AOUZ17101002, FCC ID: 2AOUZ17101010, FCC ID: 2AOUZ17101022, FCC ID: 2AOUZ17101023, FCC ID: 2AOUZ17101031, FCC ID: 2AOUZ17101032, FCC ID: 2AOUZ17101033, FCC ID: 2AOUZ17101034, FCC ID: 2AOUZ17101041, FCC ID: 2AOUZ17101042, FCC ID: 2AOUZ17101043, FCC ID: 2AOUZ17101051, FCC ID: 2AOUZ17101052, FCC ID: 2AOUZ17101053, FCC ID: 2AOUZ17101054, FCC ID: 2AOUZ17101055, FCC ID: 2AOUZ17101056, FCC ID: 2AOUZ17101057, FCC ID: 2AOUZ17101071, FCC ID: 2AOUZ17101072, FCC ID: 2AOUZ18020531, FCC ID: 2AOUZ18020532, FCC ID: 2AOUZ18020533, FCC ID: 2AOUZ18020534, FCC ID: 2AOUZ18100931, FCC ID: 2APOM-MQBA0, FCC ID: 2AVXWWSBRC001, FCC ID: 2AXPS-WPC003-1, FCC ID: 772C-LB1FD, FCC ID: BEJLCW05-VWE5, FCC ID: BEJMIB2, FCC ID: BEJMIB2PQ, FCC ID: BEJ-MEBICAS3, FCC ID: BEJ-MIBPQMIN, FCC ID: BEJ-MIB3OI, FCC ID: BEJTLAHW3IU-E, FCC ID: BEJTLAHW3IU-N, FCC ID: BEJTLVHE4IU-E, FCC ID: BEJTLVHE4IU-N, FCC ID: BEJTLVHM3IU-E, FCC ID: BEJTLVHM3IU-N, FCC ID: BEJTLVM3IU-N, FCC ID: BEJTUVM01IU, FCC ID: CWTUGZZF1, FCC ID: CWTUGZZF2, FCC ID: IYZVK2, FCC ID: KR5-BCMEVOC, FCC ID: KR5FS14T, FCC ID: KR5FS14TK, FCC ID: KR55NA920791A, FCC ID: LTQR3TR, FCC ID: NBG010180T, FCC ID: NBG010905A, FCC ID: NBG011719A, FCC ID: NBG013854, FCC ID: NBG01RS4, FCC ID: NBG011719A, FCC ID: NBG10176, FCC ID: NBG9068, FCC ID: NBG92596263, FCC ID: NBGBCMEVO, FCC ID: NBGBCMEVO5, FCC ID: NBGBCM2R, FCC ID: NBGFS09P03, FCC ID: NBGFS12A, FCC ID: NBGFS12A01, FCC ID: NBGFS12P, FCC ID: NBGFS12P01, FCC ID: NBGFS12PM, FCC ID: NBGFS12P01M, FCC ID: NBGFS125C, FCC ID: NBGFS125C1, FCC ID: NBGFS125C5, FCC ID: NBGFS173NP, FCC ID: NBGFS173NPM, FCC ID: NBGFS173NR, FCC ID: NBGFS1744M, FCC ID: NBGFS19, FCC ID: NBGFS191, FCC ID: NBGFS93N, FCC ID: NBGMQBBB, FCC ID: NBGMQB BH, FCC ID: NBGPQ12P01, FCC ID: NBGRSB19, FCC ID: NF3-FR5CPEC, FCC ID: NF3-LRR3SCU, FCC ID: NF3-LRR4, FCC ID: NF3-MRR1PLUS, FCC ID: NF3-MRR1REAR, FCC ID: NF3-MRREVO14F, FCC ID: NF3-LRR3SCU, FCC ID: NT8-FPK8IMMO5D, FCC ID: NT8-VWMIBREGIO, FCC ID: NZLADHL5D, FCC ID: NZLJCIBUSHL4, FCC ID: OAYARS4B, FCC ID: OAYARS5B, FCC ID: OYGTSSRE4UD, FCC ID: OYGTSSRE4UF, FCC ID: OYGTSSSG4G5, FCC ID: QIPALAS6A-US, FCC ID: QISME919BS-567BN, FCC ID: QISME919BS-567BNB, FCC ID: QZ9-KA3, FCC ID: RK7MBC-NAR, FCC ID: RK7MBC-NAR2, FCC ID: RK7185-00, FCC ID: RK7186-00, FCC ID: RX2BNFHL, FCC ID: RX2BNFLL, FCC ID: T8GA270, FCC ID: T8GA475, FCC ID: T8GA476, FCC ID: T8GP114, FCC ID: VPYLB1KD, FCC ID: WJLHT-5, FCC ID: NF3-FR5CUEC, FCC ID: NBG01RS55, FCC ID: NF3-F5CP42, FCC ID: NBG01RS53, FCC ID: NBGFS125C1.

Interference statement

This device complies with part 15 of the FCC Rules. Operation is subject to the following two conditions:

- (1) This device may not cause harmful interference, and
- (2) This device must accept any interference received, including interference that may cause undesired operation.

CAUTION TO USERS: Changes or modifications not expressly approved by the party responsible for compliance could void the user's authority to operate the

equipment.

FCC RF Exposure Statement

FCC ID: RK7MBC-NAR

This equipment complies with FCC radiation exposure limits set forth for an uncontrolled environment. End users must follow the specific operating instruction for satisfying RF exposure compliance. This transmitter must not be co-located or operating in conjunction with any other antenna or transmitter.

This is a CONSUMER device.

BEFORE USE, you MUST REGISTER THIS DEVICE with your wireless provider and have provider's consent. Most wireless providers consent to the use of signal boosters. Some providers may not consent to the use of this device on their network. If you are unsure, contact your provider.

You MUST operate this device with approved antennas and cables as specified by the manufacturer. Antennas MUST be installed at least 20 cm (8 inches) from any person.

You MUST cease operating this device immediately if requested by FCC or a licensed wireless service provider.

WARNING: E911 location information may not be provided or may be inaccurate for calls served by using this device.

Wireless notice

This device complies with FCC radiation exposure limits set forth for an uncontrolled environment and meets the FCC radio frequency (RF) Exposure Guidelines. This transmitter must not be colocated or operating in conjunction with any other antenna or transmitter. The antenna should be installed and operated with minimum distance of 20 cm between the radiator and your body.

FCC Class A digital device notice

NOTE: This equipment has been tested and found to comply with the limits for a Class A digital device, pursuant to part 15 of the FCC Rules. These limits are designed to provide reasonable protection against harmful interference when the equipment is operated in a commercial environment. This equipment generates, uses, and can radiate radio frequency energy and, if not installed and used in accordance with the instruction manual, may cause harmful interference to radio communications. Operation of this equipment in a residential area is likely to cause harmful interference in which case the user will be required to correct the interference at his own expense.

FCC Class B digital device notice

NOTE: This equipment has been tested and found to comply with the limits for a Class B digital device, pursuant to Part 15 of the FCC Rules. These limits are designed to provide reasonable protection against harmful interference in a residential installation. This equipment generates, uses and can radiate radio frequency energy and, if not installed and used in accordance with the instructions, may cause harmful interference to radio communications. However, there is no guarantee that interference will not occur in a particular installation. If this equipment does cause harmful interference to radio or television reception, which can be determined by turning the equipment off and on, the user is encouraged to try to correct the interference by one or more of the following measures:

- Reorient or relocate the receiving antenna.
- Increase the separation between the equipment and receiver.
- Connect the equipment into an outlet on a circuit different from that to which the receiver is connected.
- Consult the dealer or an experienced radio/TV technician for help.

Technical data

Information on technical data

General information about specifications

As long as nothing else is specified or listed, the technical data applies to the base model. Different values may result due to optional equipment, different model versions, special equipment, and country-specific equipment. The specifications in the legal vehicle documents always take precedence.

The drive and power of the vehicle are listed in the official vehicle registration.

Weight

The values for the curb weight in the following tables apply to a vehicle ready for operation with standard equipment, without a driver, with fluids. Optional equipment and retrofitted equipment will increase the specified curb weight and reduce the possible load.

The load consists of the following weight:

- Passengers.
- All luggage inside and outside the vehicle.
- Attachments.
- Trailer tongue weight if in trailer mode.

The permitted total vehicle weight and the gross axle weight rating must never be exceeded. The permissible values are indicated on the safety compliance label on the identification label on the B-pillar on the driver's side → [Safety certificate](#).

Performance

These values apply only in ideal road and weather conditions.

The performance was determined without equipment that limits performance, such as add-on parts.

Towing weight and trailer tongue weight ratings

The towing weight and trailer tongue weight ratings on the trailer hitch identification label are simply the test values for the trailer hitch. The vehicle-based specifications, which are often below these values, can be found in your vehicle documents. The specifications in the official vehicle registration or on the identification label of the vehicle or safety certificate → [Safety certificate](#) always take precedence.

Towing weight

The indicated combination weights apply only for altitudes up to 1000 m (3000 ft) above sea level. For every additional 1000 m (3000 ft), the gross combination weight rating must be reduced approximately 10%.

Incline angle

The incline angle is the specification up to which the vehicle is able to drive uphill on an angle with its own power. This can depend on the road conditions, the weather conditions, and the engine power, among other things. The values apply to a vehicle that is in motion and not to a vehicle that starts to drive from a stationary position.

A rising difference in altitude (incline) on a 100 m (300 ft) stretch is given in percentage or degrees (100% = 45 degrees).

Vehicle Identification Number (VIN)

Structure of the vehicle identification number (VIN)

The vehicle identification number (VIN, VIN) consists of 17 characters. These characters can be sorted into seven groups.

The structure is explained using the following examples of vehicle identification numbers.

Group	①			②			③		④	⑤	⑥	⑦					
Position	1	2	3	4	5	6	7	8	9	10	11	12	13	14	15	16	17
Example	W	V	W	Z	Z	Z	C	B	Z	M	E	4	0	0	9	5	3
	W	V	W	A	F	2	9	N	4	8	Y	0	0	0	0	0	1

① Vehicle manufacturer identification:

WVW Volkswagen Passenger Vehicles

WVG Volkswagen Passenger Vehicles

1VW Volkswagen Group of America Inc., Volkswagen de México, S.A. de C.V

3VW	Volkswagen de México, S.A. de C.V
XW8	LLC Volkswagen Group Rus (Volkswagen/Skoda Kaluga)
MFB	Garuda Matraman Motor (Indonesia)

② Filler characters: The filler characters may vary depending on manufacturer, or contain information on the body shape and transmission type.

③ Vehicle class, depending on model:

3H	Arteon
5T	Touran
6R	Polo
AC	T-Roc convertible
BV	Golf
CB	Passat
CA	Atlas
CR	Touareg

Depending on the manufacturer, digits 7 to 9 can also contain information on the fuel type (7) and vehicle class (8 and 9).

④ Filler characters or check digits: The filler characters or check digits may vary depending on the manufacturer.

⑤ VIN index, depending on model year:

M	2021
N	2022
P	2023
R	2024

⑥ Production location, plant where the vehicle was manufactured:

C	Volkswagen plant in Chattanooga
D	Volkswagen plant in Bratislava
E	Volkswagen plant in Emden
K	Volkswagen plant in Osnabrück Or: Volkswagen plant in Kaluga
M	Volkswagen plant in Puebla
P	Volkswagen plant in Zwickau
T	Volkswagen plant in Pune
U	Volkswagen plant in Uitenhage
V	Volkswagen plant in Palmela
W	Volkswagen plant in Wolfsburg
Y	Volkswagen plant in Pamplona

The letter assignment for the production site may vary depending on the vehicle or be assigned twice.

⑦ Sequential production number for each model year.

Position of the vehicle identification number



Fig. 184 In the windshield: vehicle identification number (VIN)

The VIN can be read from the outside through the viewing window in the windshield. The viewing window is at the side of the lower section of the windshield. In some models, it may be possible to display the VIN in the Service menu or in the vehicle settings, depending on the Infotainment system. The vehicle identification number may also be located on the identification label.

The VIN may also be stamped in the following locations, depending on the model, country and engine:

- In the right water drain channel in the hood space.
- On the right suspension strut tower in the hood space.
- In the hood space near the hinge for the hood on the right-hand side of the vehicle.
- Under the carpet behind the right front seat

Safety certificate

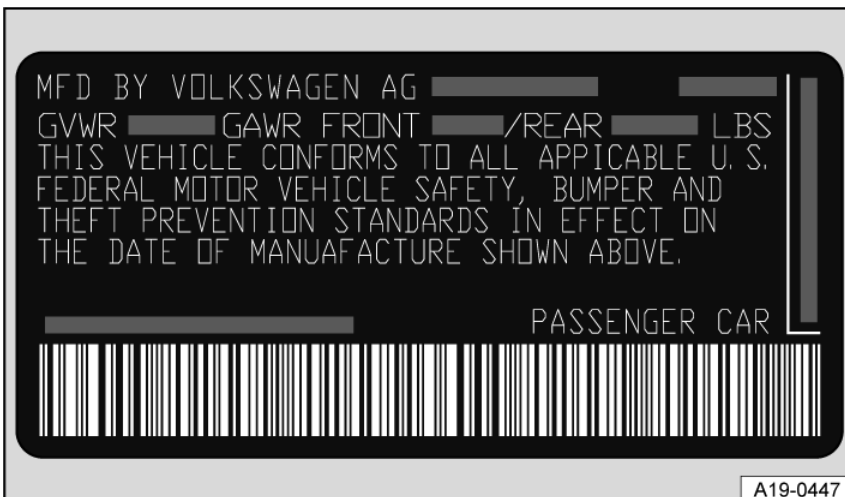

A19-0447

Fig. 185 Safety certificate (general example).

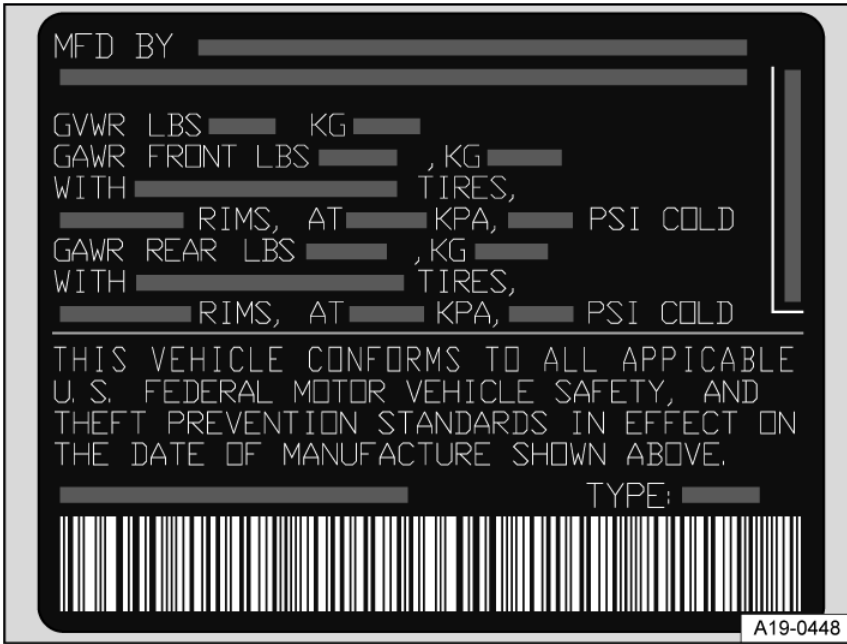

Fig. 186 Safety certificate (general example).

A safety certificate on the driver door pillar displays the following information:

- Manufacturer.
- Country of manufacture.
- Date of manufacture.
- Gross vehicle weight rating.
- Gross axle weight ratings.
- Tire size.
- Rim size
- Tire pressure.
- Vehicle Identification number.
- Type designation.

Dimensions

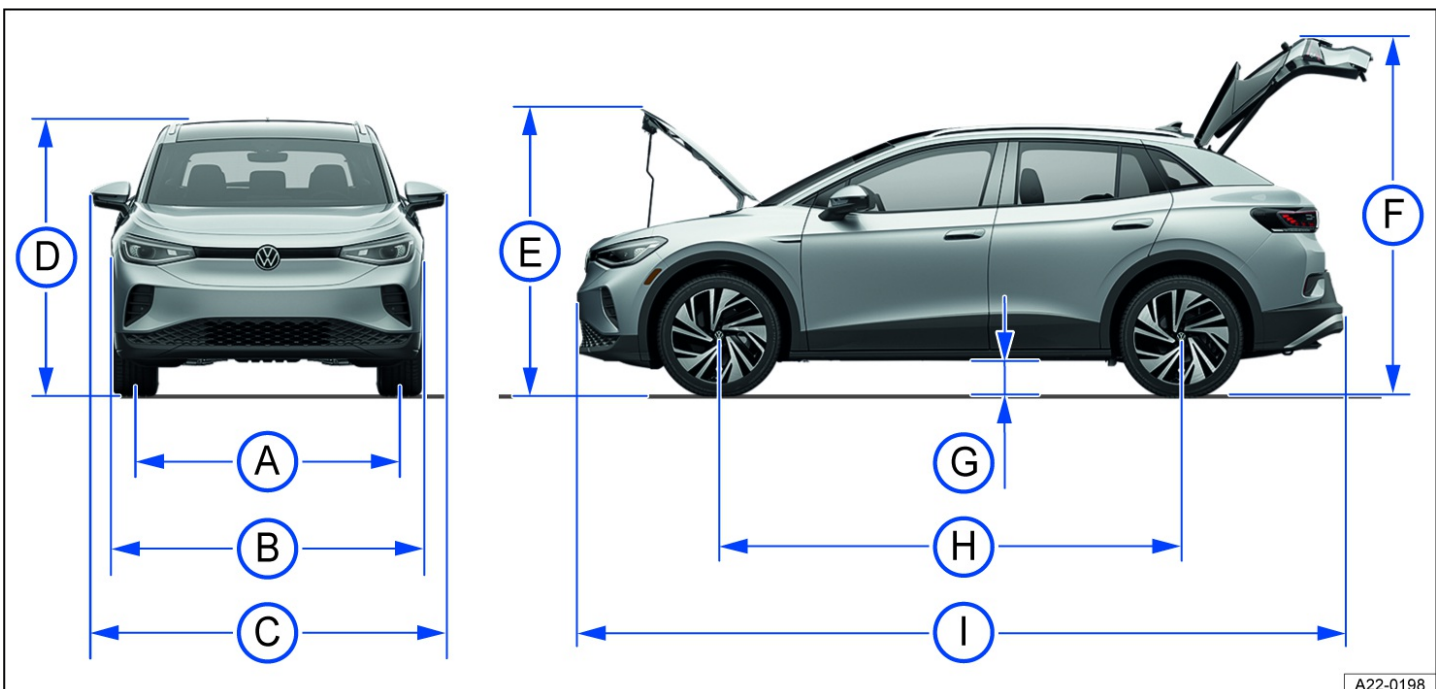

Fig. 187 Vehicle dimensions.

The information in the table applies for the standard model with standard equipment.

In the case of other rim and wheel sizes, additional equipment, different model versions and the retrofitting of accessories as well as in the case of special vehicles, these values may differ.

Information about how the weight specifications are compiled can be found in section [⇒ General information about specifications](#).

Key for fig. 187 :			R e a r- w h e e l d r i v e	A l l- w h e e l e v e (4 M O T O R I O N)
A	Front track	mm (in)	1 5 8 7 (6 2 .3))	1 5 8 3 - 1 5 8 8 7 (6 2 .3) - (6 2 5)
	Rear track	mm (in)	1 5 6 3 (6 1 .5)	1 5 6 3 (6 6 1.5)

	Key for <i>fig. 187</i> :		Rear wheel elevation	Allow height of drive (4 M O T O R I O N)
Ⓑ	Width	mm (in)	1852 (72.9)	1852 (72.9)
Ⓒ	Width from outside mirror to outside mirror	mm (in)	2108 (83)	2108 (83)
Ⓓ	Maximum vehicle height	mm (in)	1639 (66.5)	1639 (65.1)

Key for <i>fig. 187</i> :			R e a r - w h e e l d r i v e	A l l - w h e e l d r i v e (4 M O T O R I O N)
E	Maximum height with open hood	mm (in)	1 7 3 3 - 1 7 3 3 2 (6 8)	1 7 3 3 - 1 7 3 5 2 (6 8) - (6 9)
F	Maximum height with open trunk lid	mm (in)	2 1 7 8 - 2 1 7 8 (8 5 .7)	2 1 7 8 - 2 1 7 9 2 (8 5. 7) - (8 6. 3)

Key for <i>fig. 187</i> :			Rear-wheel drive (4 MOTION)	Allow wheel drive (4 MOTION)
⑥	Ground clearance between the axles	mm (in)	153 (6) - (6.8)	153 - 173 (6) - (6.8)
	Wheelbase	mm (in)	2762 - 2765 (108.9)	2762 - 2765 (110.89) - (110.9)
⑧				

	Key for <i>fig. 187</i> :			Rear-wheel drive (4 MOTION)
	Minimum turning circle diameter		m (ft)	9.11 (33.64)
①	Length from bumper to bumper		mm (in)	4584 (180.5)

①	Length with factory-installed trailer hitch	mm (in)	4692 (184.7)	4692 (184.7)
---	---	------------	-----------------	-----------------

Electric drive

150 kW (201 hp), 62 kWh, rear-wheel drive, electric motor

Engine overview

Power, maximum	kW	150
	hp	201 (SAE)
Engine code		EBJC
Maximum torque	Nm	310
	ft-lb	228.6
Maximum speed	km/h	-
	mph	-

Weight specifications and axle loads

Curb weight	kg	1958 – 2003
	lbs	4317 – 4416
Gross Vehicle Weight Rating	kg	2460 – 2530
	lbs	5423 – 5578
Front Gross Axle Weight Rating	kg	1100 – 1130
	lbs	2425 – 2491
Rear Gross Axle Weight Rating	kg	1410 – 1450
	lbs	3109 – 3197

Towing weights

Braked towing weight	kg	998
	lbs	2200
Unbraked towing weight	kg	748
	lbs	1650
Maximum gross combination weight rating	kg	3456 – 3524
	lbs	7620 – 7770
Maximum permissible trailer tongue weight rating	kg	122
	lbs	270

⁶⁾ This data was not available at the time of printing.

150 kW (201 hp), 82 kWh, rear-wheel drive, electric motor

Engine overview

Power, maximum	kW	150
	hp	201 (SAE)
Engine code		EBJA
Maximum torque	Nm	310
	ft-lb	228.6
Maximum speed	km/h	160
	mph	99

Weight specifications and axle loads

Curb weight	kg	2067 – 2108
	lbs	4557 – 4647
Gross Vehicle Weight Rating	kg	2570 – 2630
	lbs	5666 – 5798
Front Gross Axle Weight Rating	kg	1130 – 1150
	lbs	2491 – 2535
Rear Gross Axle Weight Rating	kg	1490 – 1530
	lbs	3285 – 3373

Towing weights

Braked towing weight	kg	998
	lbs	2200
Unbraked towing weight	kg	748
	lbs	1650
Maximum gross combination weight rating	kg	3565 – 3624
	lbs	7860 – 7990
Maximum permissible trailer tongue weight rating	kg	122
	lbs	270

220 kW (295 hp), 82 kWh, all-wheel drive, electric motor

Engine overview

Power, maximum	kW	220 (SAE, UN GTR)
	hp	295 (SAE)
Engine code	EBJA, EBRA	
Maximum torque (front engine)	Nm	162
	ft-lb	119.5
Maximum torque (rear engine)	Nm	310
	ft-lb	228.6
Maximum speed	km/h	180
	mph	111

Weight specifications and axle loads

Curb weight	kg	2172 – 2212
	lbs	4788 – 4877
Gross Vehicle Weight Rating	kg	2680 – 2740
	lbs	5908 – 6041
Front Gross Axle Weight Rating	kg	1200 – 1230
	lbs	2646 – 2712
Rear Gross Axle Weight Rating	kg	1530 – 1560
	lbs	3373 – 3439

Towing weights

Braked towing weight	kg	1224
	lbs	2700
Unbraked towing weight	kg	748
	lbs	1650
Maximum gross combination weight rating	kg	3900 – 3964
	lbs	8600 – 8740
Maximum permissible trailer tongue weight rating	kg	122
	lbs	270

⁷⁾ Maximum power that can be achieved in accordance with the test standards noted above, which can be called up for max. 30 seconds. The power available in a

particular driving situation depends on a number of variables such as outside temperature and temperature, charge level and condition or physical aging of the high voltage battery. To achieve maximum power availability, certain conditions must be in place, in particular a high-voltage battery temperature of between 23 and 50 °C and a charge level greater than 88%. If any of the values fall outside of the ideal ranges, particularly for the parameters just mentioned, you may experience a reduction in power and the maximum power may not be available at all. The battery temperature can be indirectly influenced to a certain degree by the stationary preconditioning function, and other parameters such as the charge level can be set in the vehicle. The amount of power that is currently available is shown on the vehicle's power display. To maximize the high-voltage battery's usable capacity, we recommend setting a battery charging target of 80% for everyday use (can be set to 100% before undertaking long trips, for example).

Abbreviations used

Abbreviation Meaning